

HighwayGuard™ Barrier

By Highway Care Limited

PRODUCT MANUAL



PN 628464

REVISION 1.1 FEBRUARY 2026



Revision History

Revision	Date	Prepared by	Approved by	Reason for change
1.0	19/04/2022	A. Marsh	O. Pulling	First issue
1.1	13/02/2026	R. Hotchkiss	G. Ridley	Loading diagram & update to Valtir

Contents

- Introduction 4**
- Valtir..... 4**
- System Configurations..... 5**
- AASHTO Soil Standard Deflection System..... 5**
- Standard Deflection System (SDS)..... 5**
- Lower Deflection System (LDS)..... 6**
- Minimum Deflection System (MDS) 6**
- System Components 7**
- Design Considerations..... 8**
- Delineation..... 8**
- Drainage 8**
- Pavement Types..... 8**
- Install Lengths 9**
- Curves..... 9**
- Deflection/Clear Zone..... 10**
- Crash Cushions/Other Connections 10**
- Modifications 10**
- Installation..... 11**
- Planning 11**
- Tools List 11**
- Lifting Points 12**
- Loading/Unloading 13**



Connection..... 14

Anchoring..... 15

Ends 15

SDS..... 15

AASHTO SDS 15

LDS..... 16

MDS..... 16

Crash Cushions 16

Anchoring Near an Excavation..... 18

Barrier Removal 18

Special Operations..... 19

Creating Access Gap 19

Bridges..... 20

Wheelsets 20

Maintenance and Repair..... 20

Recycling 20

Permanent Applications 21

Photo Examples 21

Risk Assessments 22

Installation Checklist Example 24



Introduction

HighwayGuard™ is a MASH 16 TL-3 & TL-4 compliant steel safety barrier. The 20ft (6m) single barrier section, with the unique T-Connector provides quicker installation, removal and separation of barrier sections. It also offers the ability to remove sections within a run to create access gaps, replace damaged sections or alter barrier runs.

HighwayGuard™ is an anchored steel safety barrier that can be used in temporary and permanent applications.

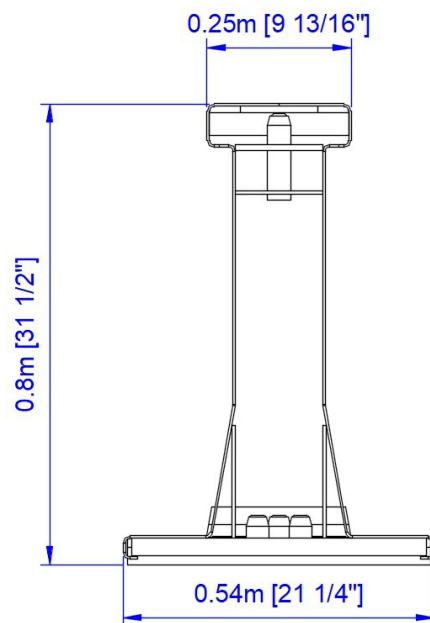

System Weight	Standard Barrier Length
62lb per foot (99kg/m)	20ft (6m)

Valtir

Valtir, LLC is the official North American distributor for HighwayGuard™ and can support your projects/installations in addition to resolving technical enquiries:

Website: <https://www.valtir.com/contact/>

Phone: (888) 323-6374





System Configurations

There are multiple configurations for HighwayGuard. All configurations use the same barrier sections and T-Connectors. The differences between the systems are the anchor interval, quantities and types:

System Configuration	Anchor Interval		Performance Level (MASH 16)	Dynamic Deflection	
	ft	m		in	m
Standard Deflection System (SDS)	138 ¹	42 ¹	TL-3	67	1.71
	190	58	TL-3	76	1.93
			TL-4	85	2.16
HighwayGuard™ Lower Deflection System (LDS)	40	12	TL-3	27	0.68
			TL-4	31	0.79
HighwayGuard™ Minimum Deflection System (MDS) ²	6.5	2	TL-3	0.98	0.025

¹AASHTO Soil Standard Deflection System

²Only requires anchoring on the traffic side of the barrier

When attaching screens to the barrier's integral post sockets, the anchoring must be suitable for wind loading.

AASHTO Soil Standard Deflection System

Ideal for rural highway applications or areas where the barrier is not able to be placed on asphalt or concrete.

The system must be anchored with a minimum of 8 driven, flat top anchors at the first and last sections in a run of barrier. For longer barrier runs, 8 additional anchors, 4 on each side of the barrier, should be spaced no more than every 138ft (42m). Refer to drawing HG-70-14 for further information.

Standard Deflection System (SDS)

The TL-3 system was tested on asphalt with 1 3/16" (30mm) diameter flat top drop in pins with typical 12" (300mm) embedment.

The system must be anchored with a minimum of 6 anchor points at the first and last sections in a run of barrier. For installations where longer runs are required, 4 additional anchors, 2 on each side of the barrier, should be spaced no more than every 190ft (58m). Refer to drawing HG-70-01 for further information.



Lower Deflection System (LDS)

Ideal for applications that allow for resin anchors to be installed in order to achieve lower deflections. The TL-3 system was tested on asphalt using M24 threaded rod anchors with typical 13" (330mm) embedment. The TL-4 system was tested on asphalt using M24 threaded rod anchors with typical 16" (400mm) embedment. Shorter anchors are available for installations in concrete.

The system must be anchored with a minimum of 6 anchor points at the first and last sections in a run of barrier. Additionally, 2 more anchors, staggered across the T-connector, should be spaced every 40ft (12m). Refer to drawing HG-70-02 for further information.

Minimum Deflection System (MDS)

The lowest deflecting anchored steel barrier in the world and is ideal for applications requiring the minimum possible deflection. The system was tested on asphalt using 1" (M24mm) threaded rod anchors with typical 16" (400mm) embedment. Shorter anchors are available for installations in concrete

The system must be anchored with a minimum of 6 anchor points at the first and last sections in a run of barrier. An additional anchor should be spaced every 6½ ft (2m) on the traffic side of the barrier. Refer to drawing HG-70-13 for further information.



System Components

20ft (6m) Barrier			End Cap
			
1217lb (552kg)			60lb (27kg)
Standard T-Connector	2.5 Degrees T-Connector	5 Degrees T-Connector	10 Degrees T-Connector
			
95lb (43kg)	133lb (60kg)	133lb (60kg)	133lb (60kg)
Wheelsets	2.5 Degrees Barrier	5 Degrees Barrier	10 Degrees Barrier
			
47lb (21kg)	294lb (133kg)	296lb (134kg)	300lb (136kg)

Note: Weights are approximate only.



20ft (6m) HighwayGuard™ to BG800® Transition



1354lb (614kg)

Design Considerations

It is important that HighwayGuard™ is planned/designed and installed in accordance with this manual and any approval/regulatory conditions placed upon its acceptance use in that territory.

Delineation

Reflective delineators may be required for both permanent and temporary applications. The specification (size, shape, colour, position) can vary in accordance to meet local regulations/requirements.

Drainage

HighwayGuard™ has a 3/8" (10mm) drainage gap underneath the barrier. Additional drainage provision is provided through the forklift points.

Pavement Types

HighwayGuard™ has been tested in a variety of pavement types and can be installed in the pavement types listed below:

- Asphalt
- Asphalt over subbase
- Asphalt over concrete
- Concrete
- Reinforced concrete
- AASHTO soil

Alternative ground conditions may be acceptable but could require different anchor solutions.

For further information regarding minimum pavement requirements and specifications refer to drawing HG-60-12.



Install Lengths

The permissible length of the system is unlimited, but the barrier must be anchored at the first and last sections of each run and intermediately as required by the system type. See recommended minimum install lengths shown below:

System Configuration	MASH 16 Test Level	Minimum system length (approx.)	
		ft	m
Standard Deflection System (SDS)	TL-3	198'	60'
	TL-3	236	72
	TL-4		
Lower Deflection System (LDS)	TL-3	100	30
	TL-4	200	60
Minimum Deflection System (MDS)	TL-3	60	18

¹AASHTO Soil Standard Deflection System

Curves

The T-Connector can allow an approximate angle of up to 0.23° for vertical connections and 0.77° between barrier sections for horizontal connections. Example horizontal curves;

Method	Description	Radius (approx.)	
		ft	m
1	20ft (6m) Barrier Section with Standard T-Connections at maximum angle	581	177
2	20ft (6m) Barrier Section with 2.5° T-Connection	460	140
3	20ft (6m) Barrier Section with 5° T-Connection	230	70
4	20ft (6m) Barrier Section with 10° T-Connection	115	35
5	20ft (6m) Barrier Section with 10° Barrier Section and Standard T-Connection	135	41
6	10° Barrier Section with Standard T-Connection	22	6.6
7	10° Barrier Section with 10° T-Connection	12	3.6



Deflection/Clear Zone

HighwayGuard™ is designed to absorb energy when impacted. When impacted between anchors deflection occurs. Hazards or obstacles that may restrict barrier operation, such as curbs or other solid objects; or work materials/equipment, must not be within the deflection area.

Vehicle roll must be considered with taller vehicles as these may protrude beyond the barrier deflection during impact.

Crash Cushions/Other Connections

Crash cushions should be used when impact to either the approach or departure end of a run of HighwayGuard™ may occur.

Current Crash cushions/ Connections available:

- **QuadGuard M10 (MASH Compliant)**
- **Highway Care BG800™ Transition (MASH Compliant)**

An engineered connection is one that has been designed and jointly agreed by Highway Care and the crash cushion developer as acceptable for use. These may also require approval from relevant road authorities – check road authority approval for guidance on acceptable options available in your market.

For additional crash cushion options, please contact Trinity Highway and Highway Care.

Modifications

No modifications are allowed to HighwayGuard™ components without prior approval from Highway Care.



Installation

HighwayGuard™ must be installed in accordance with this manual and with the latest state road authority conditions. Where conflict arises road authority conditions take priority over this manual.

Depending on the application and circumstances on-site, installation of a full trailer (42 sections) can be completed in approximately 20 minutes.

Planning

Planning well ahead of the job is essential to provide the most efficient and most suitable installation. The customer must provide information on:

- Start/end positions and alignment requirements of each barrier run (including crash cushions)
- Curvature (horizontal and vertical) required to ensure appropriate components available
- Installation site risks identified (e.g. overhead cables, bridges, tunnels, drilling limitations)
- Traffic management measures in place to ensure appropriate and safe working space

Tools List

(T)ool / (C)onsumable	Information		
(T) Magnetic T-Bar wrench or 1 3/16" (30mm) Socket	For inserting and removing the T-Connector security nut.		
(T) Drilling Equipment	Electric or air driven rock drill. Suggested drill bit sizes below:		
	Diameter	Length	Anchor type
	1 1/4" (32mm)	18" (450mm)	Driven/drop-in pins
1 1/8" (28mm)	18" (450mm)	Resin studding	
(T) Measuring Wheel & (C) Road Marking Paint	To mark barrier position where required.		
(T) 2 off 6ft (2m) crow bar/wrecking bar	To assist with minor barrier re-alignment.		
(T) Timber Blocks	To aid installation/removal on uneven ground.		
(T) Wrench	With 1 1/2" (36mm) socket.		
(C) Resin	Resin for M24 threaded anchor		



Lifting Points

Caution

Do not use the T-Connection lifting points to lift barrier sections (highlighted by red circles). These are for lifting the T-Connection only.

Ensure lifting equipment is certified and in a safe/useable condition.

Each 20ft (6m) barrier section has two designated lifting points allowing hooks to attach marked in green below.

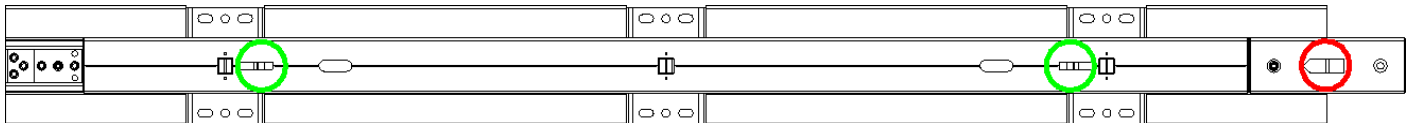

When two 20ft (6m) sections are bolted together they can be lifted as a single 40ft (12m) piece using the lifting points either side of the central T-Connection.

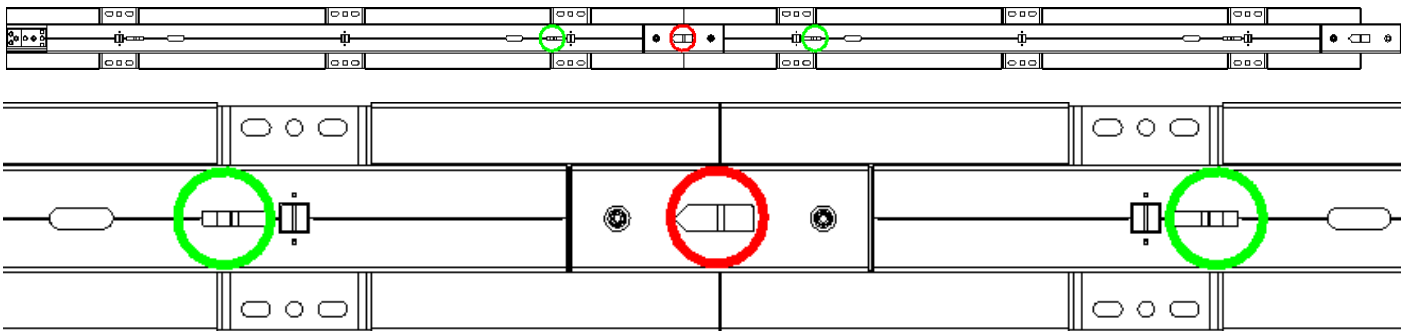

It is also possible to lift inverted sections using the designated lifting points on the underside of the barrier. When lifting a 40ft (12m) section use the two lifting points either side of the T-Connection.

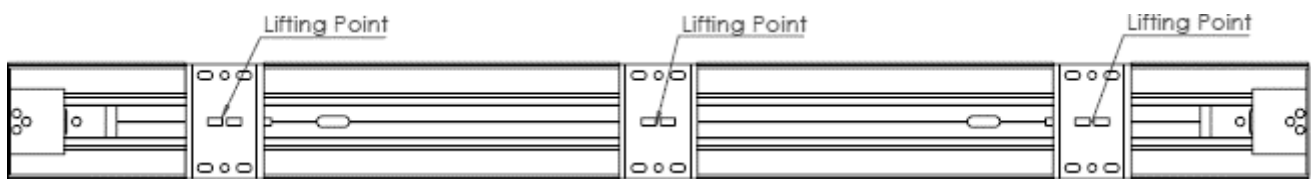

Lifting Equipment	Information
Mechanical/Pneumatic Lifting Device	Such as a truck mounted crane or wheeled excavator. It must have suitable lifting capacity and reach to install HighwayGuard™. Lifting grab (see photo example section)
Lifting Chains	Two leg assembly with a 5512lb (2500kg) lifting capacity, each chain is 6ft 6" (2m) long c/w hook, locking clasp and shortening clutch.
Tag Rope	Suggested 1.5 times the lifting height of the barrier.



Loading/Unloading

Caution

Ensure all barrier sections are secured to the truck bed with adequate ratchet straps prior to transport movements.

HighwayGuard™ can be inverted to maximise the length of barrier per load.

Check local regulations for potential weight/transport restrictions.

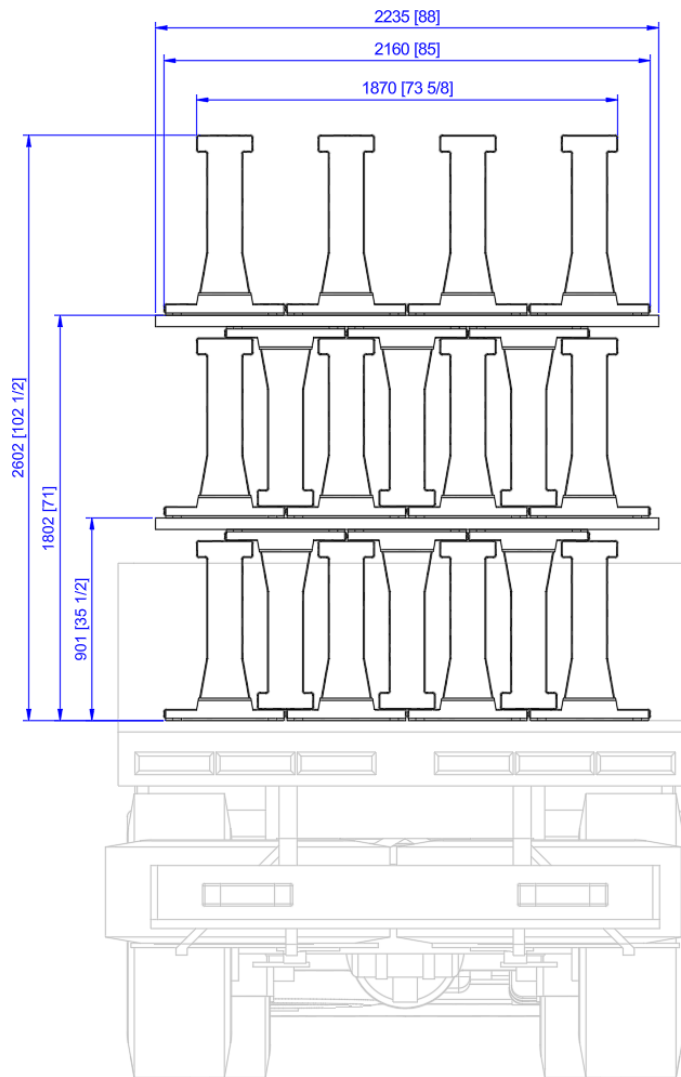

708ft (216m) Typical loading arrangement

When loading with the T-Connection attached to barrier sections; position these so that they will match the orientation of the install to avoid turning barrier round on site. Typically, they will be at the rear of the trailer.



Connection

Barrier sections are lowered into position with the T-Connection already attached to the end of the barrier that is being joined to the run of barrier. Ensure orientation of T-Connector allows alignment pins to be lowered onto next section.

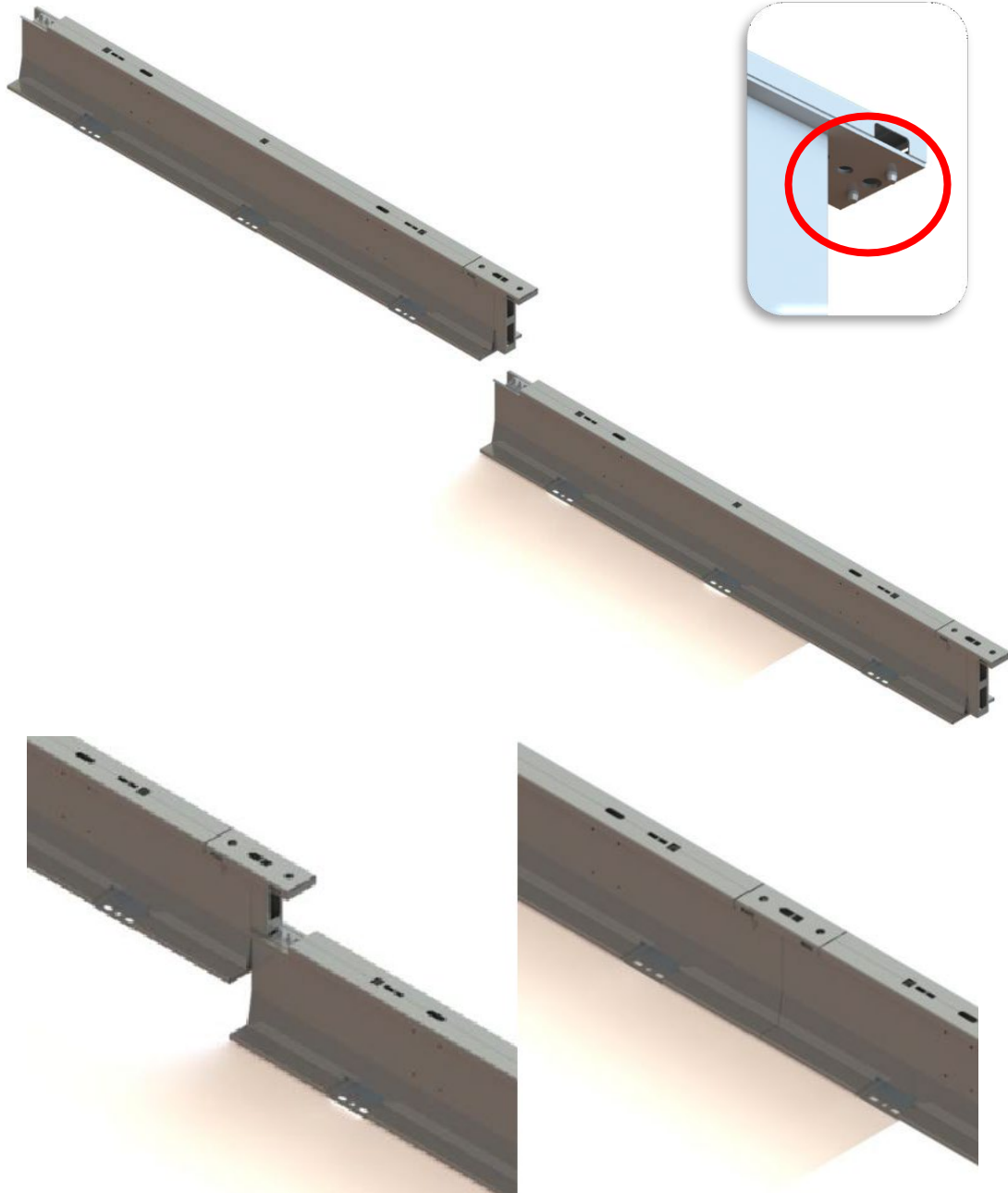

Caution

Ensure all barrier sections being lifted have a tag line attached. Joining barrier sections present's a crush risk. Ensure the operator has a clear view and can communicate when barriers are being connected.



Anchoring

Ends

All HighwayGuard™ configurations must be anchored with a minimum 6 anchor points at the first and last sections in a run of barrier. This will be in the first and last two 20ft (6m) barrier sections as shown below. When using a crash cushion additional anchors are required. See applicable section below.

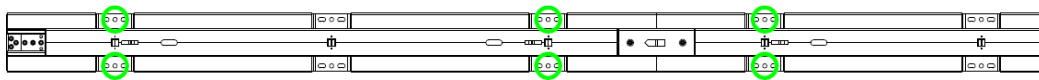

Crash cushions or connections/transitions should be used when impact to either the approach or departure end of a run of HighwayGuard™ may occur.

SDS

For Standard System installation where longer runs are required, 4 anchors are then added every 190ft (58m) as shown below;

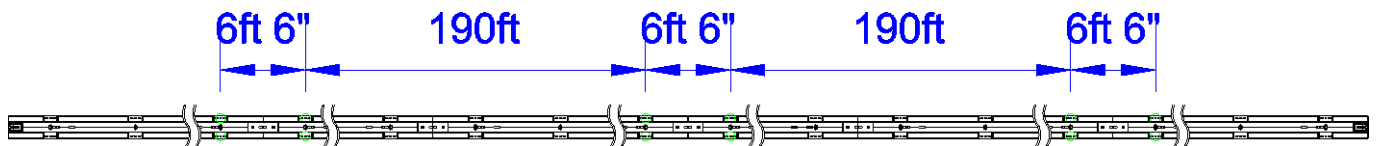

The TL-3 Standard System was tested with 1 3/16" (30mm) diameter by 14" (350mm) long flat top drop in pins.

AASHTO SDS

When installing into AASHTO soil or equivalent, the anchor interval must be reduced to 138ft (42m) intervals and anchored as shown below using driven pins. A total of 8, 1 3/16" (30mm) diameter by 20" (500mm) long driven pins must be installed.

The pins must be driven in, a sledgehammer is recommended.





LDS

For the Lower Deflection System, the 2 anchors are spaced every 40ft (12m) but staggered over the T-Connection.

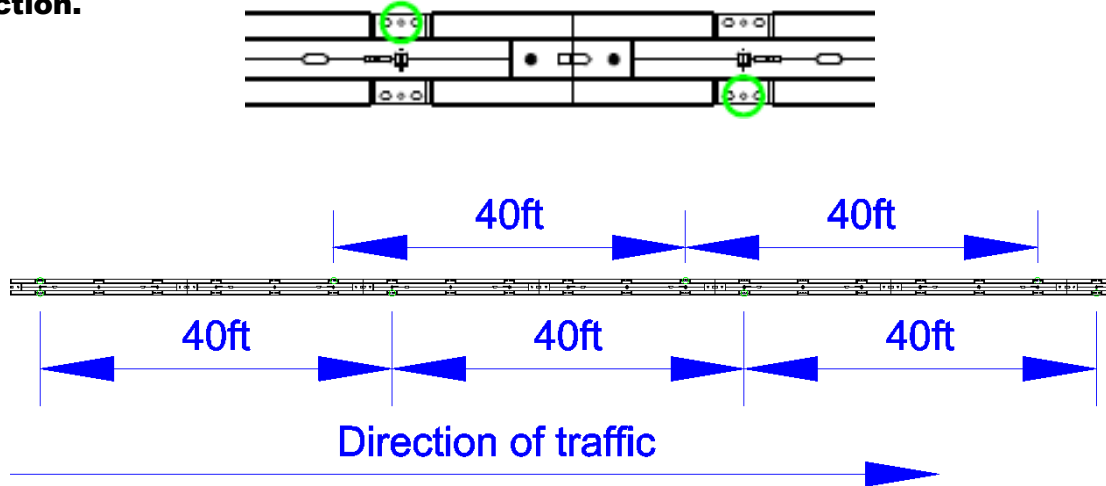

The LDS system was tested with 14" (350mm) long M24 grade 8.8 resin threaded bar for TL-3 & 18" (450mm) long M24 grade 8.8 resin threaded bar for TL-4.

MDS

For HighwayGuard MDS the anchors are installed at every anchor position (6ft 6" (2m) intervals) on the traffic side of the barrier.

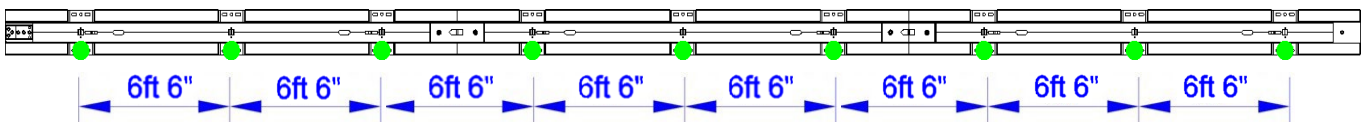

The MDS system was tested with 18" (450mm) long M24 grade 8.8 resin threaded bar.

For additional anchor details and information, please refer to drawing: HG-60-12 - HighwayGuard Foundation Details.

Crash Cushions

When using crash cushions, HighwayGuard™ barrier must be anchored at the start and end of runs at the following anchoring locations.



These anchors are 18" (450mm) long M24 grade 8.8 resin threaded bar.



Where there is bi-directional traffic and the QuadGuard M10 is being used, in addition to the HighwayGuard™ barrier anchors shown above a transition assembly must be used and anchored with 14 off 3/4" (M20) grade 8.8 resin threaded bar (1" (24mm) drill bit) with 1ft 3" (400mm) embedment as shown below (7 anchors either side of the transition assembly).

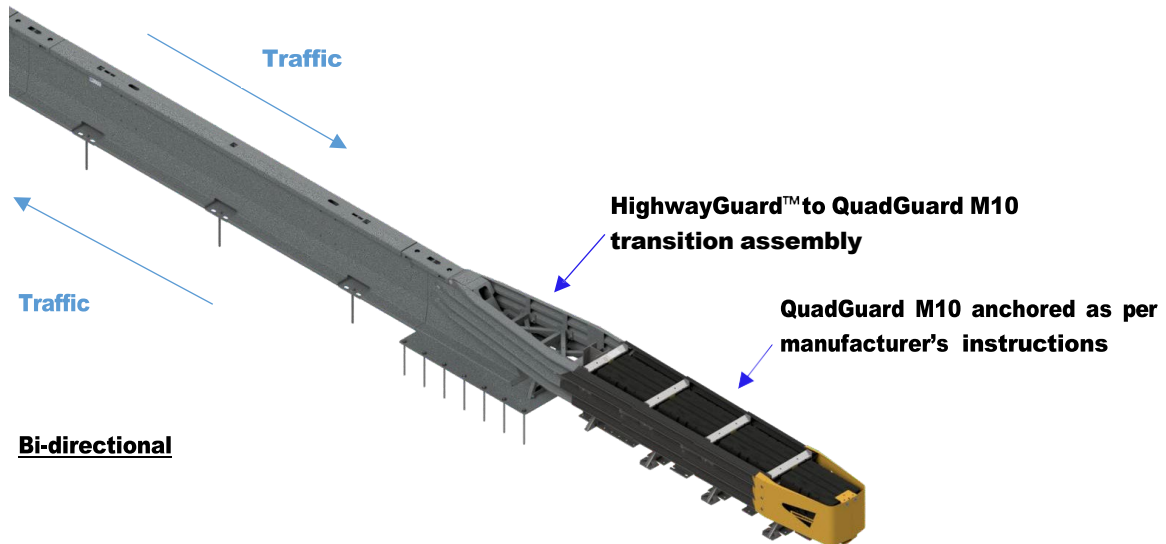

When installing in uni-directional traffic using the QuadGuard M10, the transition assembly is not required for installation.

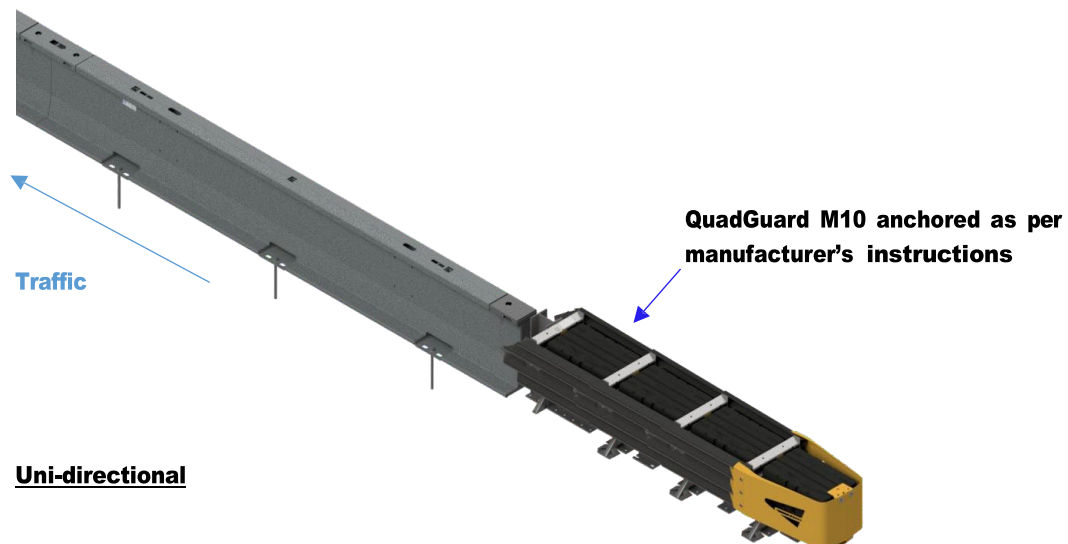



Anchoring Near an Excavation

For single sided anchoring (MDS only) and full details please refer to HG-60-08.

Surface	Asphalt		Concrete	AASHTO
Anchor Type	Drop-in Pin	Resin threaded bar	Resin threaded bar	Driven Pin
Edge distance (minimum)	22" (550mm)	18" (450mm)	12" (300mm)	22" (550mm)

The edge distance may need to be increased dependent on-site specific conditions and deflection between anchor pins should be considered prior to installation.

Barrier Removal

To remove the barrier sections, it is the reverse of the installation process. Namely;

- Release from the ground
- Remove security nut from the side of the T-connector you wish to separate
- Lift barrier section and T connector from the adjoining section
- If it is necessary to remove the T-connector separately it can be removed by hand or by plant equipment.
- If the section of barrier being removed lifts the next section, place a 2" high block under the foot of the section being removed next to the joint to be separated and lower the barrier. It will then separate. Excessive force to make or break connections is not required, address any alignment issues prior to joining/separating to prevent damage.





Special Operations

Creating Access Gap

Lift out individual sections by disconnecting the T-Connection and removing the security nut. The section can now be lifted out. In addition, sections with wheelsets can be wheeled out opposed to being lifted out.

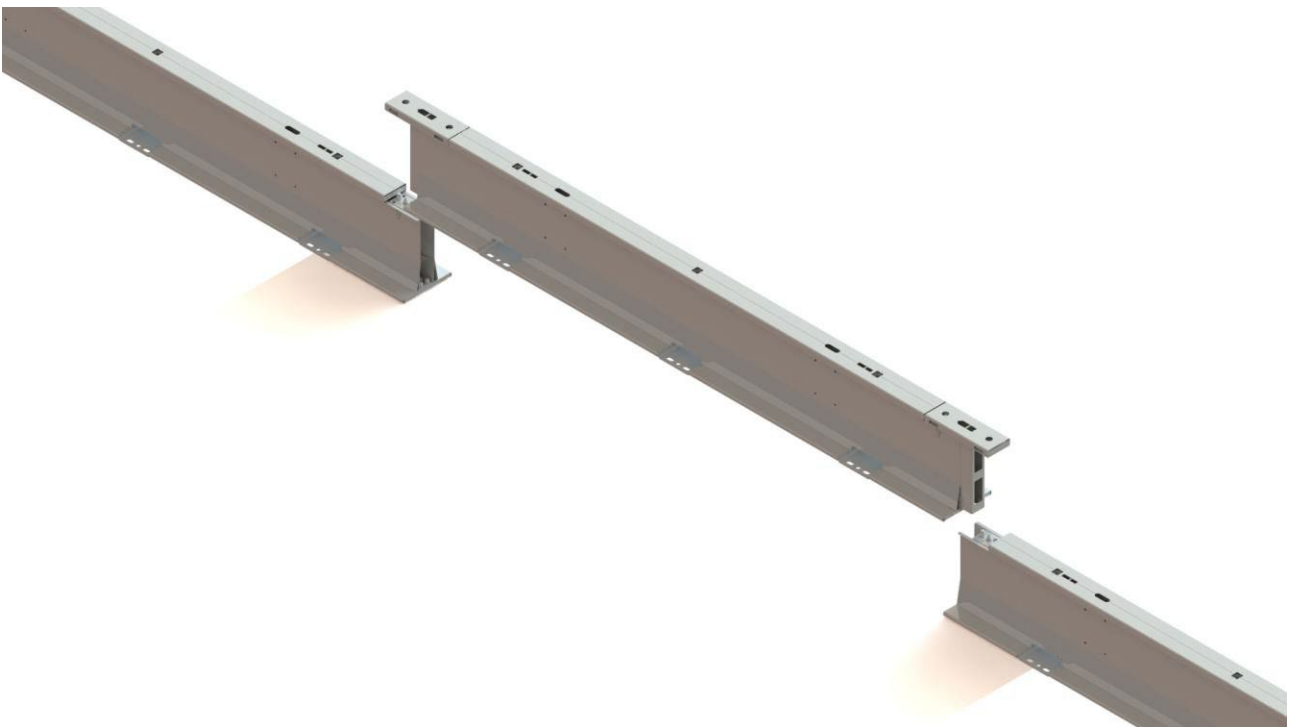
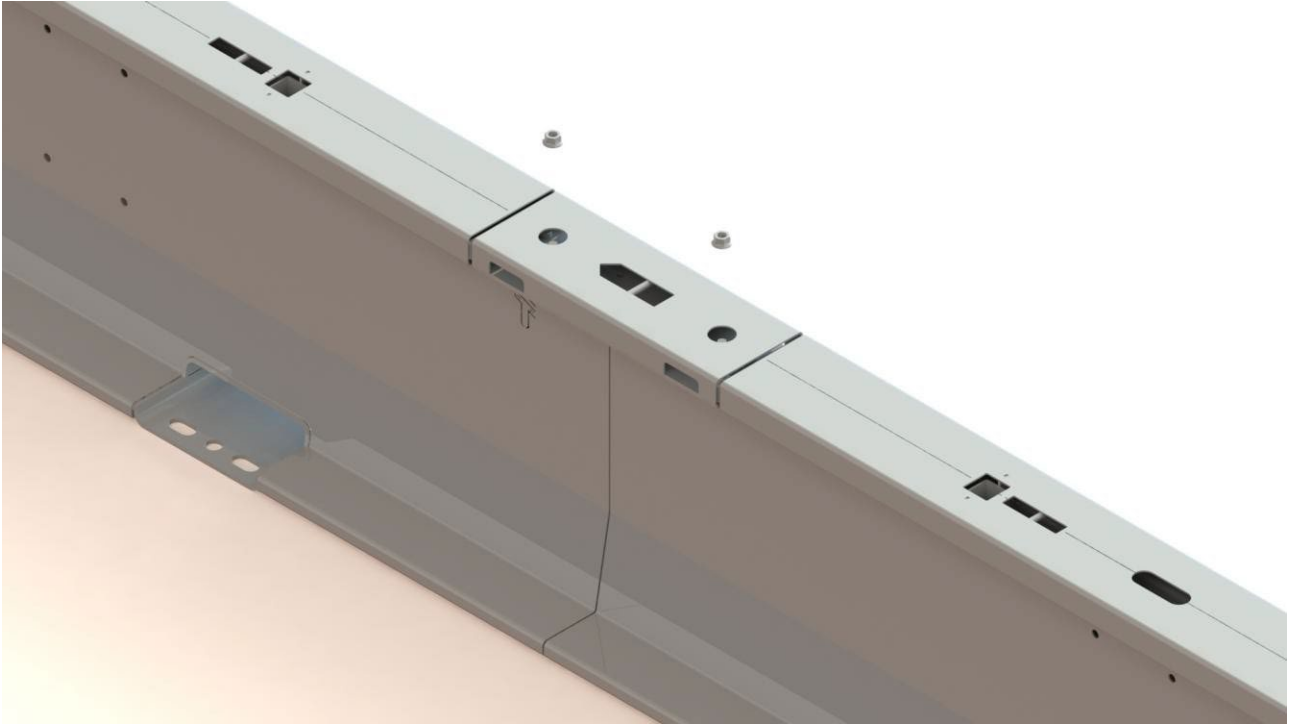



Bridges

Where possible anchoring should take place off bridge decks. Any anchoring on bridge decks needs to be agreed in advance with the technical expert responsible for the bridge to ensure it is not damaged. If anchoring either side of a bridge deck expansion joint, then this movement must be mirrored in the barrier.

Wheelsets

These allow barrier sections to be maneuvered without lifting machinery/equipment such as installing in tunnels or areas with overhead restrictions.

The wheelsets can be raised and lowered from the top of the barrier using a manual wrench and 25mm socket.

Caution

Impact guns must not be used to operate the wheels.

Maintenance and Repair

HighwayGuard™ is generally a maintenance free barrier. It is recommended that a basic visual inspection is carried out when the barrier sections are installed and uplifted to check for damage from vehicle impacts/site plant machinery or other environmental factors.

More thorough maintenance should be carried out on the system every 10 years, this involves a visual check for signs of corrosion/damage both outside and inside the barrier.

HighwayGuard™ has an expected lifespan of over 20 years. This is dependent on maintenance regime and site-specific environment.

For wheeled sections ensure that they are raised/lowered and maneuvered around, greasing the jacking mechanism if required on an annual basis.

Any damage to the galvanized coating should be repaired with zinc rich paint to prolong the life of the barrier.

Damage after vehicle impact will need to be assessed on a case-by-case basis by a competent person, typically low angle impacts will not warrant barrier replacement. Significant impacts will mean damaged sections will need to be lifted out and replaced. Heavily damaged sections may be recycled at a local facility at scrap value.

Recycling

HighwayGuard™ barrier and its T-Connectors are steel manufactured, and this is commonly recyclable around the world. It may be necessary to remove T-Connectors to split HighwayGuard™ assemblies into 6m barrier sections only – contact authorized recycling centres for guidance.



Permanent Applications

For permanent applications the following conditions apply;

- **M24 threaded bar with resin is recommended for anchoring.**
- **After initial installation it is recommended that the site is revisited after 1 month for inspection. After this it is recommended that a basic visual inspection is carried out annually, with a thorough inspection of the system every 10 years.**

Photo Examples

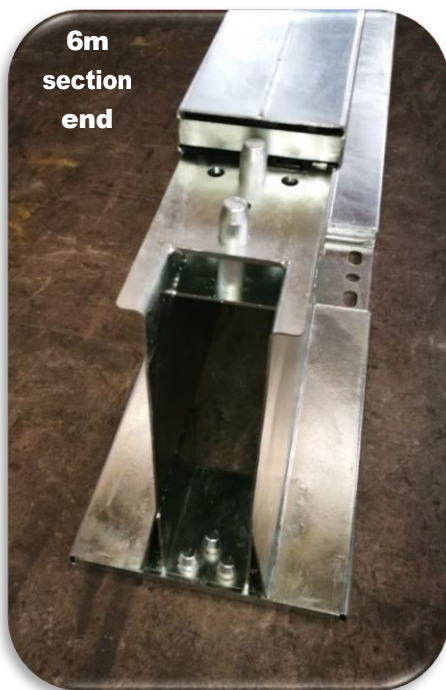



Risk Assessments

Hazard	Scenario	Precautions to minimize the risk	Method
Injury to head	Loading and unloading barrier Maneuvering barrier Installing barrier	Use of PPE (hard hats) Competent crane operator/ spotter Operative to be vigilant	Instruction Training Training
Injury to hands	Loading and unloading barrier Maneuvering barrier Installing barrier	Use of PPE (gloves) & correct tools Competent crane operator/ spotter Operative to be vigilant	Instruction Training Training Training
Injury to feet	Loading and unloading barrier Maneuvering barrier Installing barrier	Use of PPE (safety boots) Competent crane operator/ spotter Operative to be vigilant	Instruction Training Training
Load slipping from crane	Loading and unloading barrier Maneuvering barrier	Use certified approved slings/lift equipment Competent operative	Inspection Training
Uncontrolled Load	Loading and unloading barrier Maneuvering barrier	Use correct tag rope Competent operators Establish correct safety zones	Training Training Training
Slinger falling from vehicle/load	Loading and unloading barrier Maneuvering barrier Installing barrier	Safe access and egress to vehicle and load Operative to be vigilant	Training Training
Injury from site traffic	Loading and unloading barrier Maneuvering barrier Installing barrier	Correct site management procedures Operatives to be vigilant	Training Training
Injury from traffic	Loading and unloading barrier Maneuvering barrier Installing barrier	Correct traffic management procedures Operatives to be vigilant	Training Training



Working on a Live Roadway

When working on a live roadway, a safety zone is required between the working area and the live traffic lane. It is not possible to install HighwayGuard™ unless such a safety zone is provided. It is suggested that a minimum area of not less than 1ft 9” (550mm) will be required between the HighwayGuard™ and the safety zone.

Coring/Drilling for installation of anchor system

Hazard	Precautions to minimise the risk	Actions
Electrocution Damage to underground services	Before installation procedure: Inspect service plans; Use cable locating equipment and mark the position of underground apparatus. Inspect drill & drill bit	Training
Injury to eyes	Use of PPE (goggles)	Training
Injury to ears	Use of PPE (earmuffs)	Training
Dust inhalation	Use of PPE (face mask)	Training
Injury to skin from chemical anchor resin	Use of PPE (gloves)	Training
Injury from traffic	Correct traffic management procedures followed and operatives to be vigilant	Training

Righting Inverted Units/Inverting Units

Hazard	Precautions to minimise the risk	Actions
Load slipping	Use certified slings Use competent slinger	Inspection Training
Injury to heads	Use of PPE (hard hat)	Instruction
Injury to feet	Use of PPE (steel toe capped safety boots)	Instruction
Injury to legs	Undertake operation in safe restricted area under control of competent banksman and crane operator	Training & Instruction
Death or injury as a result of manoeuvring truck	All truck movements under control of competent banksman	Training
Injury from collision with passing traffic	Correctly installed traffic management	Training



Installation Checklist Example

Installation Checklist				Barrier Run Information		
	Print Name	Sign Name	Date	Location;		
Installed by;				Number of runs;		
Inspected by;				Overall Length;		
				Project Number;		
HighwayGuard™				Applicable Section; Yes or No		
Is the site suitable for HighwayGuard™?				Yes	N/A	No
Are the pavement conditions suitable?				Yes	N/A	No
Are the anchors selected suitable for the pavement condition?				Yes	N/A	No
Are all the components available?				Yes	N/A	No
Are any crash cushions installed correctly?				Yes	N/A	No
Are the start and end of the barrier run installed correctly with all 6 anchors installed?				Yes	N/A	No
Are all the QuickLink security nuts installed?				Yes	N/A	No
Has any intermediate anchoring been used? If so, note the spacing here_____				Yes	N/A	No
If BG800™ transition has been used does the anchoring arrangement match how it was tested?				Yes	N/A	No
Check there are no snagging points (more than 9/16" (14mm))				Yes	N/A	No
Delineators installed?				Yes	N/A	No



For more complete information on Valtir products and services, visit us on the web at www.valtir.com. Materials and specifications are subject to change without notice. Please contact Valtir to confirm that you are referring to the most current instructions.

WWW.VALTIR.COM
1.888.323.6374

