

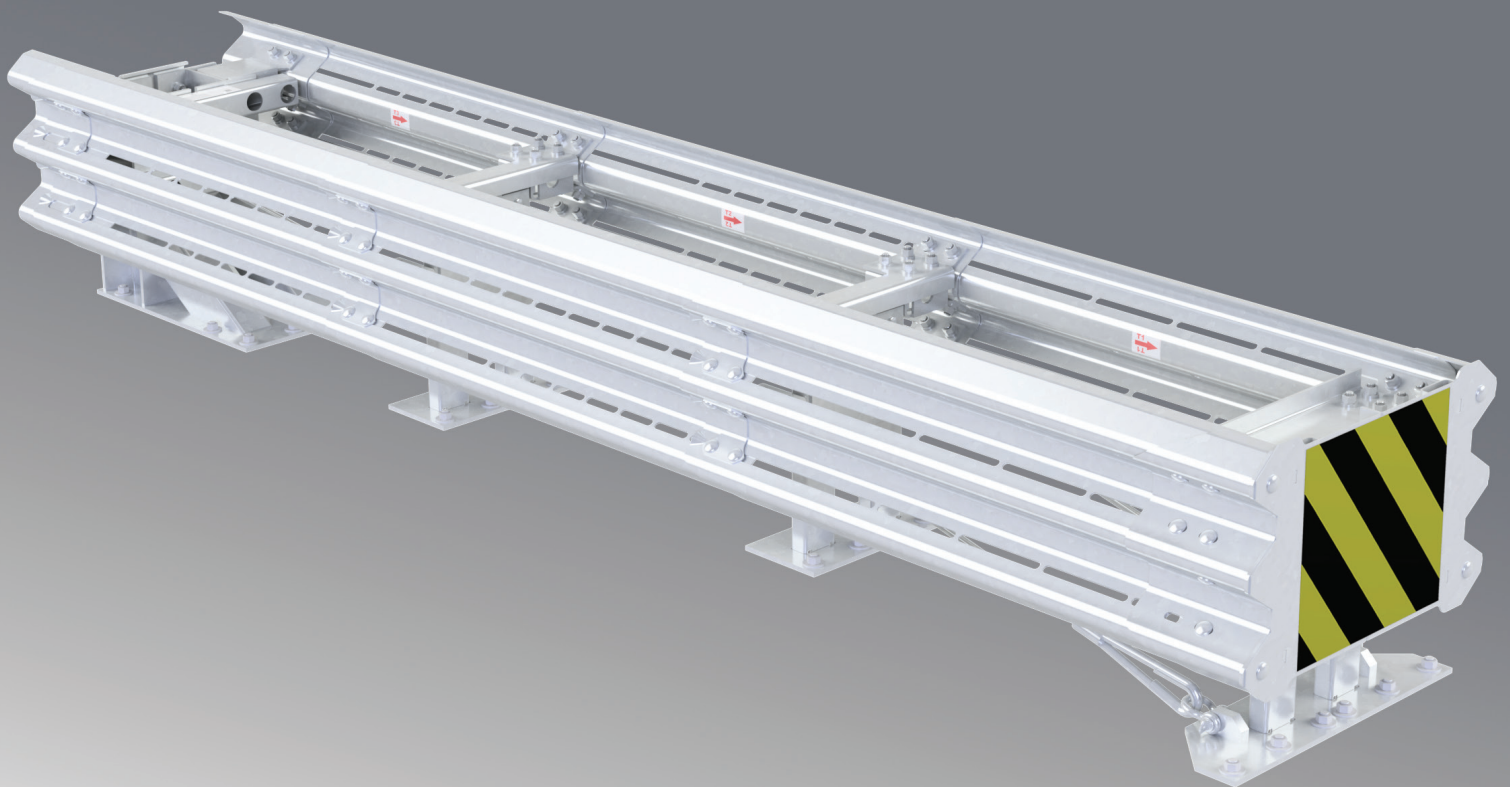

# CENTRA™ 610 80K

## PRODUCT MANUAL



**PN 120068**

SEPTEMBER 2023

# CENTRA™ 610 80K

The CENTRA™ system has successfully met all provisions described in European Standard  
EN 1317-5:2007+A2:2012 and EN 1317-5:2007+A2:2012/AC:2012.

## Product Manual



15601 Dallas Parkway  
Suite 525  
Addison, Texas 75001  
[www.valtir.com](http://www.valtir.com)



**WARNING:** The local highway authority, distributors, owners, contractors, lessors, and lessees are **RESPONSIBLE** for the proper assembly, maintenance, and repair of the CENTRA™ 610 80K. Failure to fulfill these **RESPONSIBILITIES** with respect to the proper assembly, maintenance, and repair of the system could result in serious injury or death.



These instructions are for standard assembly specified by the appropriate highway authority. In the event the specified system assembly, maintenance, or repair would require a deviation from standard assembly parameters, contact a Valtir representative.

**This manual must be available to the worker overseeing and/or assembling the product at all times. For additional copies, contact Valtir or visit [valtir.com](http://valtir.com).**

The instructions contained in this manual supersede all previous information and manuals. All information, illustrations, and specifications in this manual are based on the latest CENTRA™ 610 80K information available to Valtir at the time of printing. We reserve the right to make changes at any time. Please contact Valtir to confirm that you are referring to the most current instructions.

# TABLE OF CONTENTS

Customer Service Contacts . . . . .	1
Important Introductory Notes . . . . .	1
Safety Symbols . . . . .	2
Safety Rules for Assembly. . . . .	2
Limitations and Warnings . . . . .	2
System Overview. . . . .	3
Technical Specifications . . . . .	4
Site Preparation . . . . .	4
Foundation/Anchoring. . . . .	5
Lifting Instructions (Optional) . . . . .	6
Transitions (Optional) . . . . .	7
Plastic Nose (Optional). . . . .	7
System Installation . . . . .	8
System Components . . . . .	9
Diaphragm Spacing . . . . .	10
Step 1 - Anchoring . . . . .	11
Step 2 - End Panel & Fender Panel (T3) Assembly. . . . .	13
Step 3 - Fender Panel (T2 - T1) Assembly. . . . .	14
Step 4 - Head Panel Assembly. . . . .	15
Step 5 - Front Diaphragm Torque Verification . . . . .	16
Step 6 - Diaphragm Torque Verification. . . . .	17
Step 7 - Backup Torque Verification . . . . .	18
Step 8 - Impact Head Assembly . . . . .	19
Step 9 - Panel Fastener Torquing . . . . .	20
Step 10 - Cable Assembly . . . . .	21
Assembly Checklist . . . . .	22
Inspection. . . . .	22
Inspection Log . . . . .	23
Parts List . . . . .	24

## Customer Service Contacts

---

Valtir is committed to the highest level of customer service. Feedback regarding the CENTRA™ 610 80K system assembly procedures, supporting documentation, and performance is always welcome. Additional information can be obtained from the contacts below:

### Valtir

#### Telephone:

USA Headquarters  
+1-214-589-8140

Europe  
+44 7631 864735

Middle East - Africa  
+46 709 66 10 55

Asia - Pacific - AUS - NZ  
+1+214+589+8140

Canada  
+1-214-589-8284

Caribbean - Latin America  
+1-916-644-9108

#### Internet:

[valtir.com/contact](http://valtir.com/contact)

## Important Introductory Notes

---

Proper installation of the CENTRA™ 610 80K system is critical to achieve tested performance. The system has successfully met all provisions described in European Standard EN 1317-5:2007+A2:2012 and EN 1317-5:2007+A2:2012/AC:2012. These instructions should be read in their entirety and understood before assembling the system. These instructions are to be used only in conjunction with the assembly of the system and are for standard assemblies only as specified by the applicable highway authority. If you need additional information or have questions, please contact the highway authority that has planned and specified this assembly and, if needed, contact Valtir's Customer Service Department. This product must be assembled in the location specified by the appropriate highway authority. If there are deviations, alterations, or departures from the assembly protocol specified in this manual, the device may not perform as tested.



DO NOT use any component part that has not been specified and/or approved for this system during assembly or repair.

This product has been specified for use by the appropriate highway authority and has been provided to that user who has unique knowledge of how this system is to be assembled. No person should be permitted to assist in the assembly, maintenance, or repair of this system that does not possess the unique knowledge described herein. These instructions are intended for an individual qualified to both read and accurately interpret them as written. These instructions are intended only for an individual experienced and skilled in the assembly of highway products that are specified and selected by the highway authority.

A manufacturer's drawing package will be supplied by Valtir upon request. Each system will be supplied with a specific drawing package unique to that system. Such drawings take precedence over information in this manual and shall be studied thoroughly by a qualified individual who is skilled in interpreting them before the start of any product assembly.

## Safety Symbols

---

This section describes safety symbols that may appear in the CENTRA™ 610 80K manual. Read the manual for complete safety, assembly, operating, maintenance, repair, and service information.



Indicates Danger or Warning. Failure to read and follow this warning could result in serious injury or death to the workers and/or bystanders.



Indicates Caution or High Importance. Failure to follow this warning can result in improper performance, failure of operation, to serious injury or death in the event of a vehicle impact with the system.



Indicates Notifications or Reference. These denote important items but will not cause system damage or serious injury.

## Safety Rules for Assembly

---

This manual must be kept in a location where it is readily available to persons who are skilled and experienced in the assembly, maintenance, or repair of the CENTRA™ 610 80K system. Additional copies of this manual are available from Valtir. Please contact Valtir if you have any questions concerning the information in this manual.



It is the responsibility of the installer to use proper safety precautions when operating power equipment and when moving heavy equipment or CENTRA™ 610 80K system components. Hand, eye, foot, and back protection is recommended.



Ensure that all of the Danger, Warning, Caution, and Important statements within the CENTRA™ 610 80K manual are completely followed. Failure to follow this warning could result in serious injury or death in the event of a collision.

## Limitations and Warnings

---

Valtir contracts with accredited testing facilities to perform crash tests, evaluation of tests, and reporting of results for submission to RISE Research Institutes of Sweden AB for review.

The CENTRA™ 610 80K system was tested to meet the requirements and guidelines of the criteria described in European Standard EN 1317-5:2007+A2:2012 and EN 1317-5:2007+A2:2012/AC:2012.

The required tests are not intended to represent the performance of products when impacted by every vehicle type or every impact condition existing on the roadway. The tests are performed to measure impacts involving vehicles specified by EN 1317-3:2010.

The CENTRA™ 610 80K system is certified to **80 km/h [50 mph]**.

Valtir expressly disclaims any warranty or liability for injury or damage to persons or property resulting from any impact, collision, or harmful contact with products, other vehicles, or nearby hazards or objects by any vehicle, object, or person, whether or not the products were assembled in consultation with Valtir or by third parties.

The system is intended to be assembled and maintained in accordance with specific local guidelines. The appropriate highway authority approved engineer should be careful to properly select, assemble, and maintain the product. Careful evaluation of site layout, traffic speed/type, direction, and visibility are some of the elements that require evaluation by the highway authority in the selection of a highway product. For example, curbs could cause an untested effect on an impacting vehicle.

After an impact occurs, the debris from the impact should be removed from the area immediately and the specified highway product should be evaluated and restored to its original specified condition or replaced as the highway authority determines as soon as possible.



Do not assemble, maintain, or repair the CENTRA™ 610 80K until you have read this manual thoroughly and completely understand it. Ensure that all Danger, Warning, Caution, and Important statements within the manual are completely followed.



Do not modify the CENTRA™ 610 80K system in any way.



It is the sole responsibility of the project engineer and/or local highway authority and its engineer to ensure that the CENTRA™ 610 80K and delineation used meet all local specifications.



It is the sole responsibility of the project engineer and/or local highway authority and its engineer to ensure that your assembly meets all appropriate local standards.

## System Overview

Crash testing results have shown that the CENTRA™ 610 80K is a re-directive crash cushion for hazards up to 610 mm [24"] wide. The steel backup frame of the system is designed to be placed against and nest around the hazard. For some lower speed impacts, the system may be repaired by replacing any panels or parts that were damaged. Determining if the system is reusable after an impact is at the sole discretion of the designated highway authority specifying the use of the system.

The system meets testing criteria described in the European Standard EN 1317-3. The system has been shown to redirect vehicles that impact along its side at angles up to 15° with the axis of the system as specified in EN 1317-3. The system has also been shown to stop vehicles that impact the end of the system at angles up to 15° as specified in EN 1317-3.

The system has passed current requirements and guidelines of the 80 km/h performance class using CEN criteria for EN 1317-3.

The listed full-scale crash tests have been conducted and passed.

EN 1317-3 Test No.	Vehicle Mass (kg)	Impact Speed (km/h)	Impact Angle & Impact Point
<b>CENTRA 610 80K Crash Cushion</b>			
TC 1.1.100	900	100	0°, nose center
TC 1.3.110	1500	110	0°, nose center
TC 2.1.100	900	100	0°, nose 1/4 vehicle offset
TC 3.3.110	1500	110	15°, nose center
TC 4.3.110	1500	110	15°, redirect at L/3
TC 5.3.110	1500	110	165°, redirect at L/2
TC 1.2.80	1300	80	0°, head-on center

**CEN directed tests are not intended to represent the performance of systems when impacted by every vehicle type or every impact condition existing on the roadway. This system is tested only to the test matrix criteria of EN 1317-3 as approved by the EU.**

# Technical Specifications

## Dimensions (nominal)

- [A] - System Length . . . . . 4.27 m [14'-0 1/8"]
- [B] - Effective Length . . . . . 3.88 m [12'-8 3/4"]
- [C] - System Width. . . . . 819 mm [32 1/4"]
- [D] - System Height . . . . . 721 mm [28 1/2"]
- [E] - Obstacle Width . . . . . 610 mm [24"]

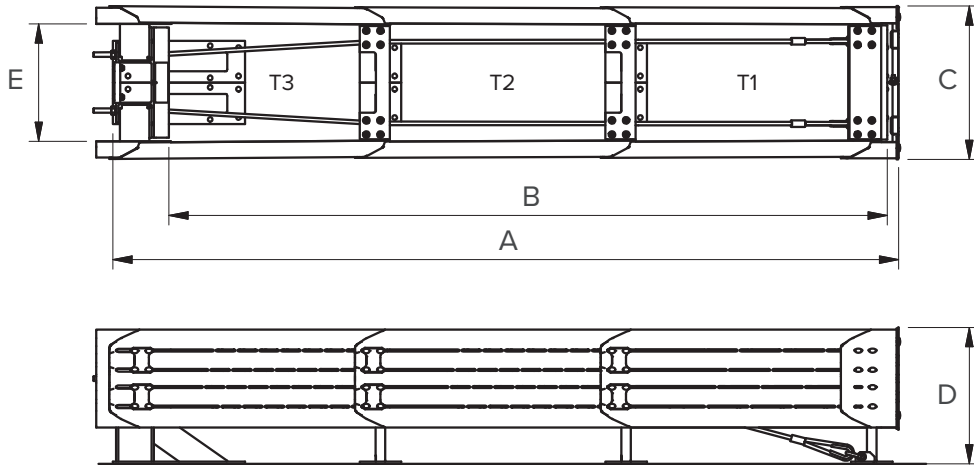

## Site Preparation

The CENTRA™ 610 80K system must be assembled on an existing or freshly placed and cured concrete foundation (28 MPa [4000 psi] minimum). Location and orientation of the concrete foundation and attenuator must comply with project plans or as otherwise determined by the local highway authority.

Recommended dimension and reinforcement specifications for new concrete foundations are in the site-specific drawing package provided with each system. The system may be assembled on a reinforced or non-reinforced concrete roadway (minimum 203 mm [8"] thick). Deployment cross-slope shall not exceed 8% and shall not twist more than 2% over the length of the system. The foundation surface shall have a light broom finish. Allow the concrete to cure a minimum of seven days before installing anchoring.

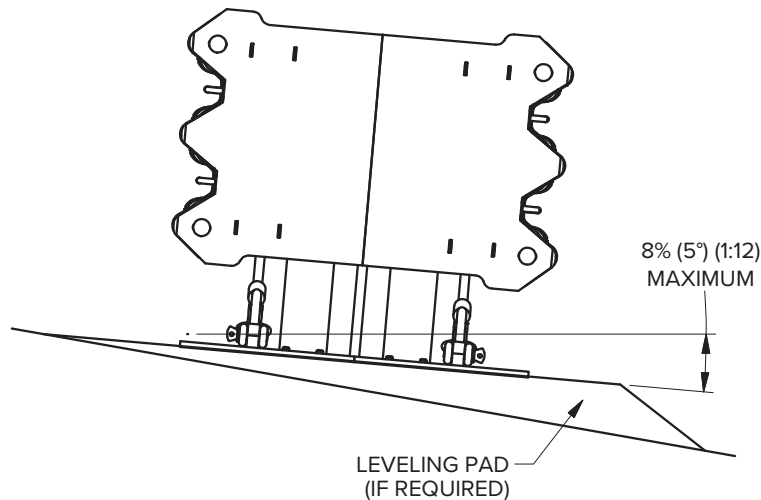

## Approach Zone and Clear Zone

The CENTRA™ 610 80K system should not be placed directly behind a raised curb. The approach area in front of the system in the direction of traffic flow should slope at a rate of no more than 10% (6°) (1:10) from the surrounding area. The cross-slope should not differ from the surrounding area by more than 8% (5°) (1:12). The clear zone behind the system should be consistent with the area behind the downstream length-of-need of the barrier.

## Downstream Zone

The CENTRA™ 610 80K system must be assembled so a 1.00 m [40"] clear space will exist on both sides of the backup structure for the Side Panels to retract during an end-on impact (Figure 11).

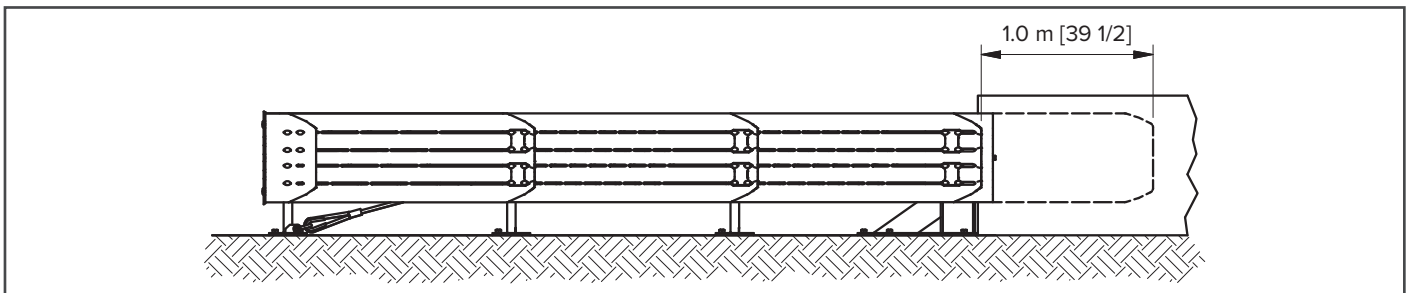

## Foundation/Anchoring

### Concrete Pad Installation

#### Foundation A: Reinforced concrete pad or roadway

Foundation: 152 mm [6"] minimum depth portland cement concrete with anchor block

Anchorage: Approved adhesive with M20 x 180 mm [3/4" x 7"] Class 8.8 studs at 140 mm [5 1/2"] embedment

#### Foundation B: Reinforced or non-reinforced concrete pad or roadway

Foundation: 203 mm [8"] minimum depth portland cement concrete

Anchorage: Approved adhesive with M20 x 180 mm [3/4" x 7"] Class 8.8 studs at 140 mm [5 1/2"] embedment

#### Foundation C: Asphalt Over Sub-Base

Foundation: 152 mm [6"] minimum depth asphalt over 152 mm [6"] minimum compact sub-base (C.S.)

Anchorage: Approved adhesive with M20 x 460 mm [3/4" x 18"] Class 8.8 studs at 425 mm [16 3/4"] embedment

## Valtir Approved Adhesive Anchoring System

A Valtir approved adhesive anchoring system is required to securely anchor crash cushions. Each approved adhesive kit contains adhesive, studs, nuts and washers.

## Anchoring



Follow adhesive manufacturer's requirements for safety, storage, handling, working time, cure time, and torque specifications.

1. Valtir approved adhesive systems are required to securely anchor crash cushions. Each approved kit contains adhesive, studs, nuts, washers, and instructions. Anchor kits may be ordered separately from Valtir.

Valtir Approved Anchors					
Anchors Required	Anchor Size [Concrete Only]	Class	Anchor Kit P/N [No Adhesive]	HILTI HIT-HY200R [500 ml]	Anchor Kit P/N [Adhesive]
24	M20 x 180 mm	8.8	627216	4 CONTAINERS	627096



- Use the part that is to be anchored as a drilling template. Drill the boreholes 22 mm [7/8"] diameter to the recommended depth. See the approved adhesive instructions provided with your kit. Check to ensure each borehole is drilled to the proper depth as shown below and aligned with the part to be anchored.

Anchoring Information				
Foundation Type	Stud Size	Concrete Bit Size	Minimum Depth	Recommended Torque
Concrete	M20 x 180 mm [3/4" x 7"]	22 mm [7/8"]	140 mm [5 1/2"]	see adhesive specification.
Asphalt	M20 x 460 mm [3/4" x 18"]	22 mm [7/8"]	425 mm [16 3/4"]	14 N·m [10 lb-ft]

- Anchor studs shall be galvanized and conform to Class 8.8. Anchor nuts shall be galvanized and conform to ASTM A194. Washers shall be galvanized steel and conform to ASTM F436.
- Blow the concrete dust from the borehole using oil-free compressed air. Thoroughly brush it with a 22 mm [7/8"] diameter steel bristle tube brush and then blow it out again. If the borehole is wet, completely flush it with water while brushing and then blow it clean to remove all water. Alternatively, a hollow concrete drill bit with an approved vacuum system may be used to prepare and clean the boreholes.
  - Fill the borehole to the top of the pavement surface. Fill from the bottom-up to prevent air pockets.
  - Insert anchor stud through a flat washer and anchor nut. Thread anchor nut onto the anchor stud until the end of the anchor stud is flush with the top of the anchor nut.
  - Insert the anchor stud through the part to be anchored and into the borehole.
  - Once the adhesive has fully cured, torque the nut to the adhesive manufacturer's specification.

### Rebar

Per the project engineer's recommendation, if rebar is encountered while drilling a borehole, the rebar may be drilled through or the borehole may be drilled at an angle. If drilled at an angle, both holes are to be filled with anchor adhesive.

### Lifting Instructions (Optional)

The CENTRA™ 610 80K system can be pre-assembled and lifted to a desired installation site. The system requires adequate support to prevent any damage while being lifted. The fender panels on the system are designed to shear and collapse during a vehicle impact and cannot be used as supports while the system is being lifted. Since the diaphragms are only connected by the fender panels, support beams are required to ensure rigidity and prevent the system from bowing or twisting in any direction while being lifted.

To ensure accurate positioning, the use of a drilling template for the backup assembly can be supplied at no cost upon request.

Consult your Valtir representative for more information.



User assumes all risk for failing to properly lift the CENTRA™ 610 80K system. Improper lifting techniques can result in damage of the system and/or possible injury.

## Transitions (Optional)

---

The CENTRA™ 610 80K system can be used in unidirectional and bidirectional applications. Transition panels must be added to any side exposed to traffic if there is potential of vehicle interaction on the impacting face or the end of a roadside obstacle. The proper transition panel to use will depend on the direction of traffic and what type of barrier or roadside obstacle the system is shielding. Contact the Customer Service Department for additional information.

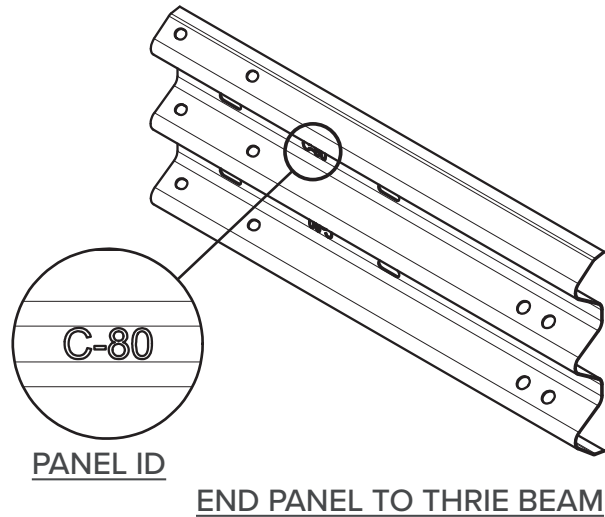

Consult Valtir for additional information on how to attach your system to one of the following barriers:

- W-Beam Guardrail
- Thrie-Beam Guardrail
- Concrete Median



The system backup must not become a roadside obstacle to reverse direction traffic. A system placed with traffic approaching from the rear may require transition hardware.

## Plastic Nose Cover (Optional)

---

An optional plastic nose cover is available for installation. Check local highway regulations to determine if this optional component is required.

## System Installation

### Obstacle

Typically the installation base point of the CENTRA™ 610 80K system will be the midpoint of the roadside obstacle at its front face. This may change depending on obstacle width or if bidirectional traffic is present (refer to the provided drawing package for details). Mark a centerline from the base point, perpendicular to the roadside obstacle face, or as determined by project engineer, to a distance greater than the maximum length of the system.

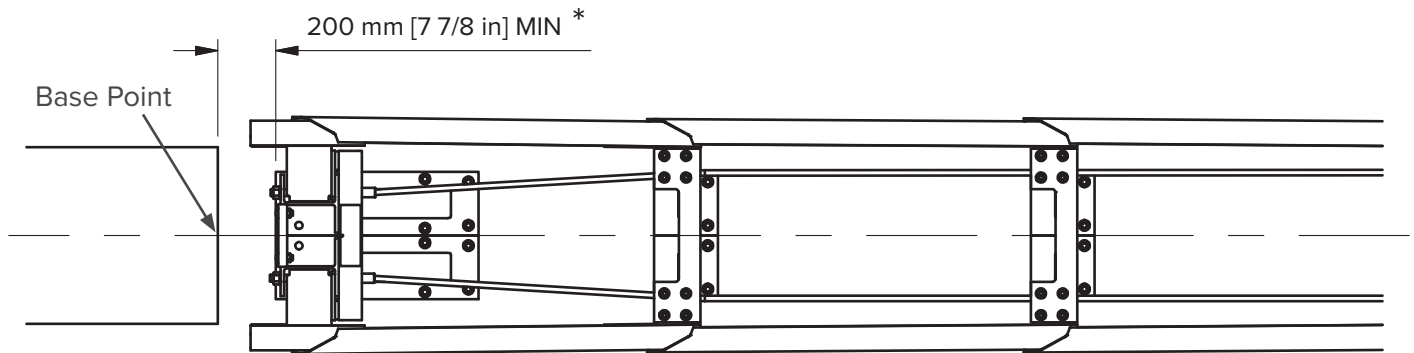

### Pad Foundation

The base of the backup should be located 200 mm [7 7/8"] from the back of the pad

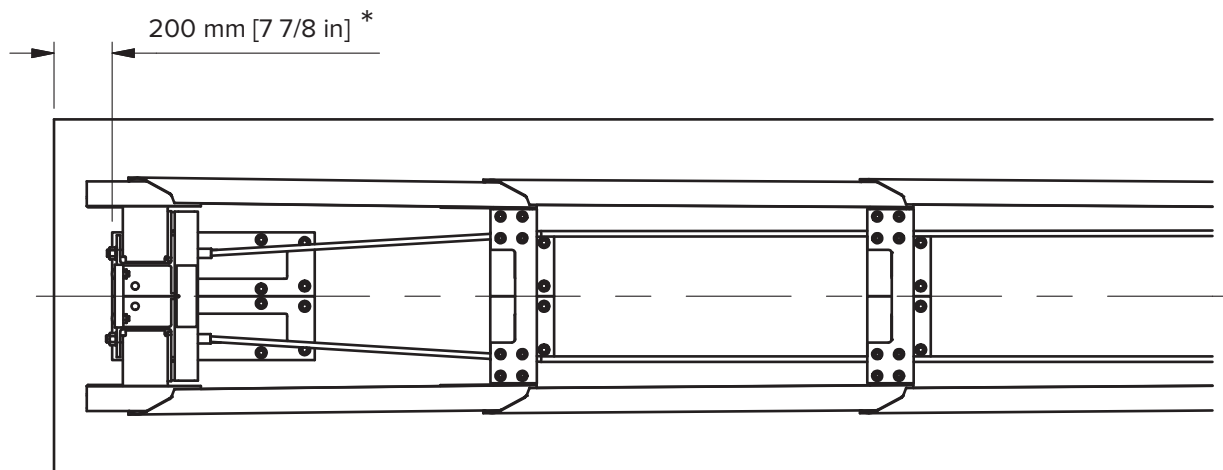

\* This distance is required for cable maintenance and to verify system information.

# System Components

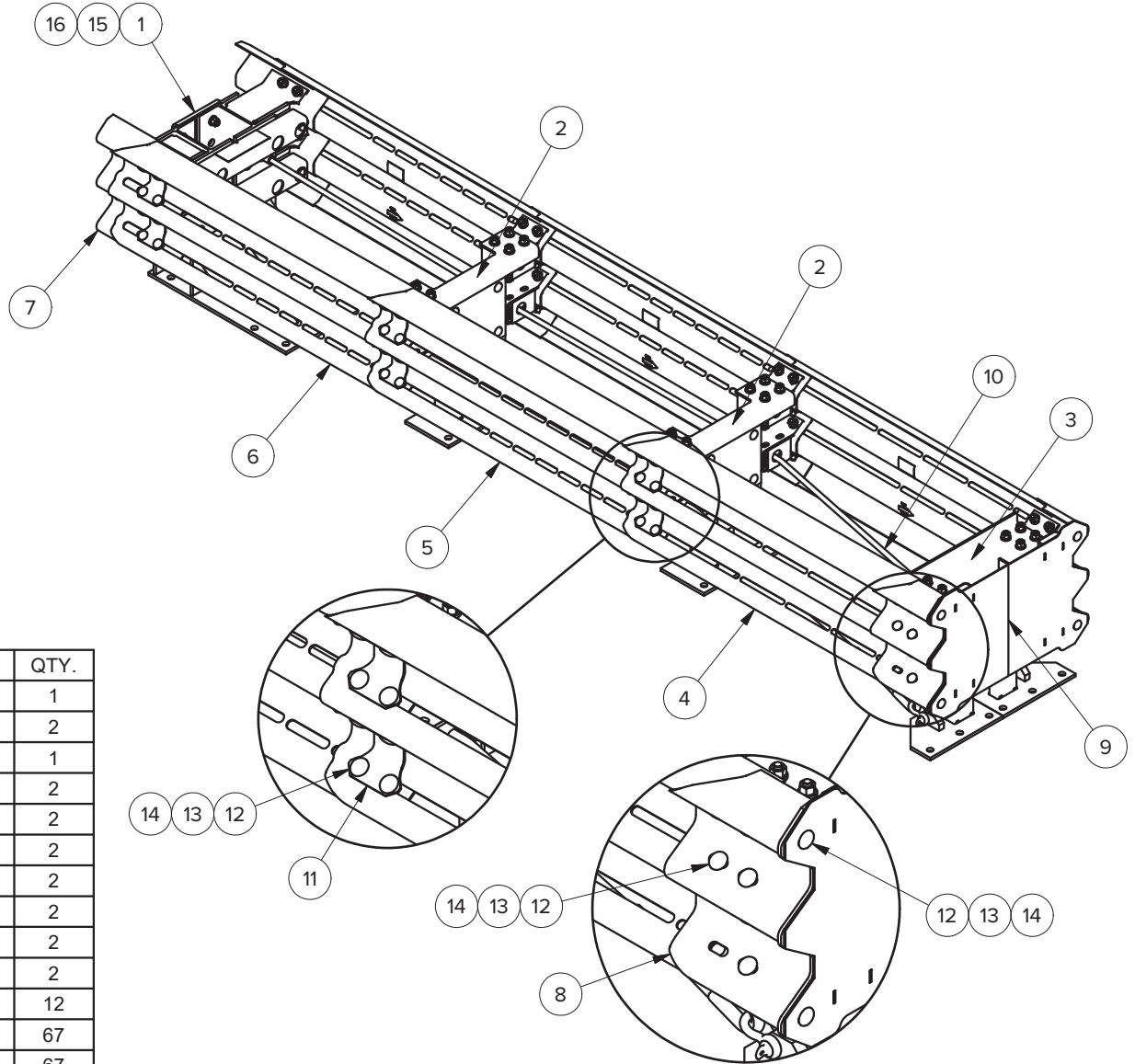

ITEM	PART NO.	DESCRIPTION	QTY.
1	627373	BACKUP ASSEMBLY,CENTRA 610	1
2	627051	DIAPHRAGM ASSEMBLY	2
3	627060	FRONT DIAPHRAGM ASSEMBLY	1
4	627062	FENDER PANEL,TYPE 1,W/DECAL	2
5	627064	FENDER PANEL,TYPE 2,W/DECAL	2
6	627066	FENDER PANEL,TYPE 3,W/DECAL	2
7	627093	PANEL,END,80,G	2
8	627079	RAIL ASSY,HEAD,G	2
9	627076	IMPACT HEAD,HALF ASSY	2
10	627094	CABLE ASSY,W/SHACKLE,4042	2
11	627080	BACKING PLATE,G	12
12	119126	BOLT,RAIL,M16X2X43,8.8,G	67
13	627050	WASHER,FLAT,M16,6mm THICK,G	67
14	116011	NUT,HX,M16X2,10,G	67
15	118437	TACK,METAL,1/4	1
16	119610	DECAL,APPROVALS,CENTRA,80	1

# Diaphragm Spacing

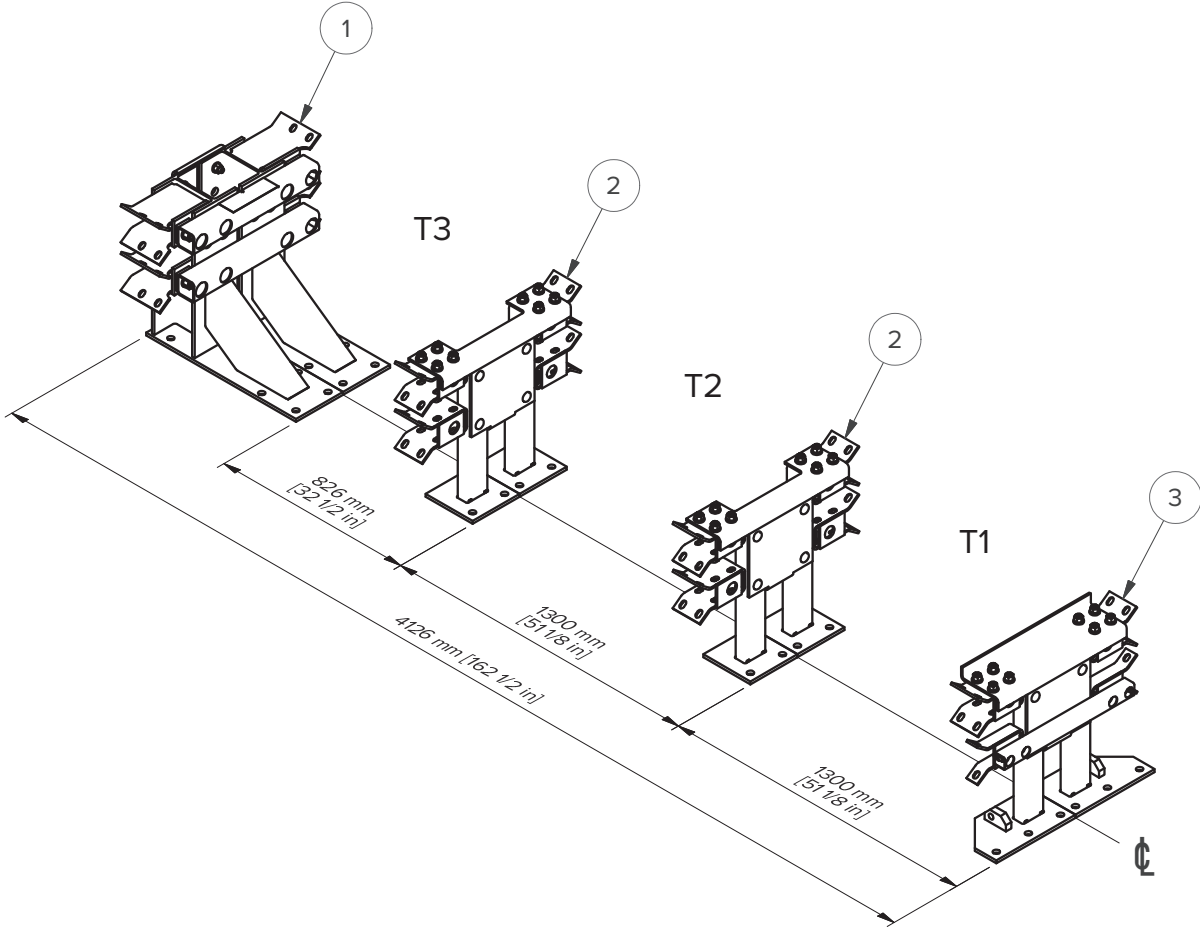

### Step 1 - Anchoring

Install anchors according to the manufacturer's instructions. A backup anchor location template is available upon request (P/N: 627248). See the Foundation/Anchoring section above.

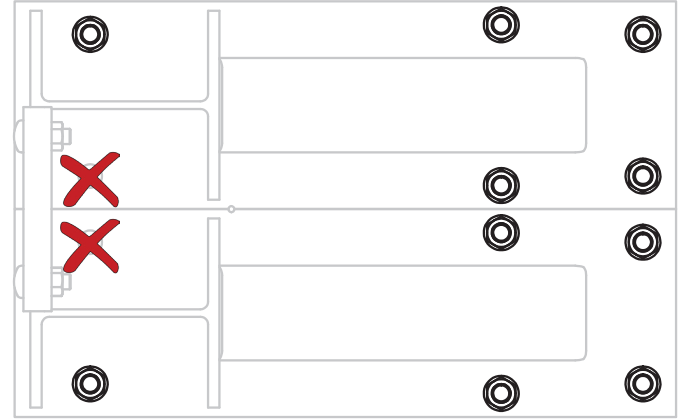
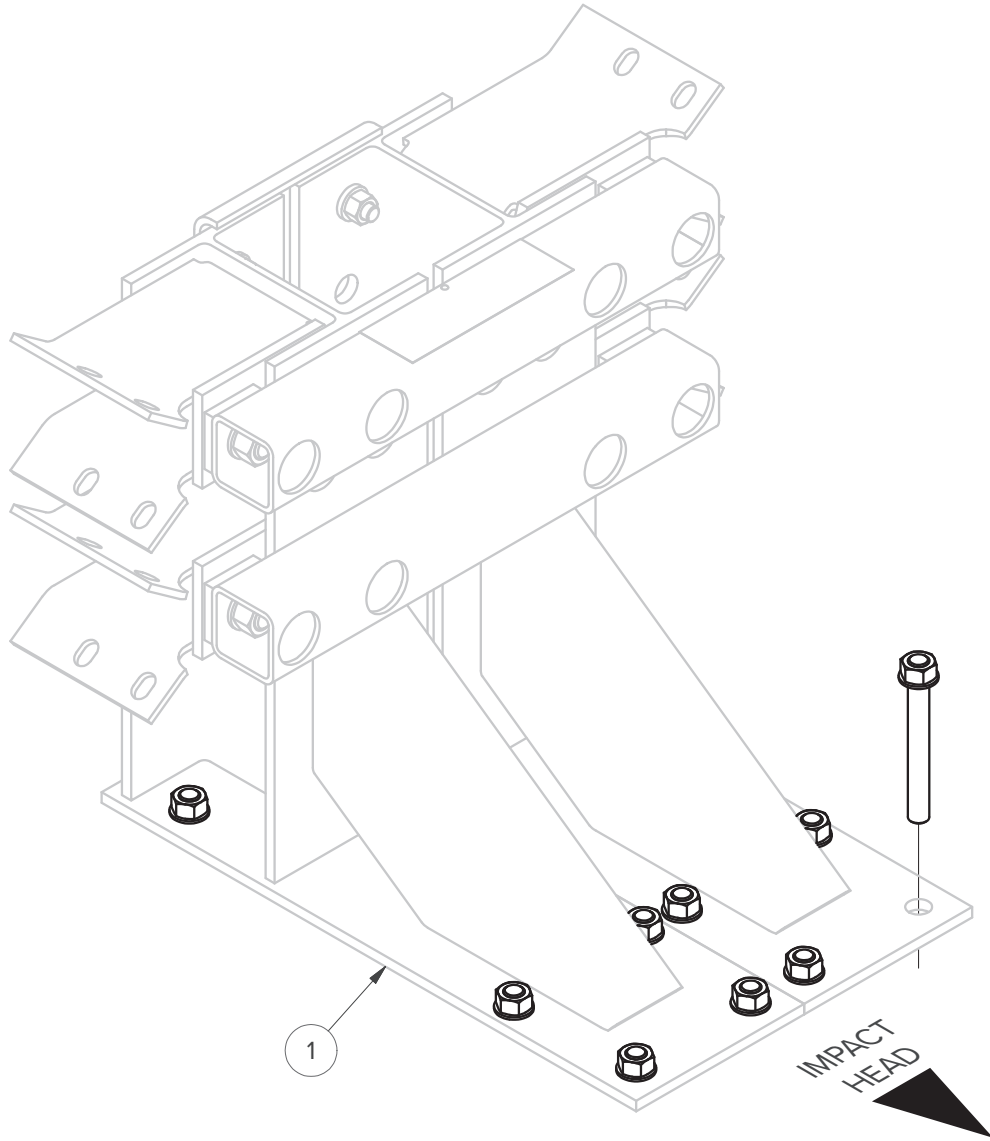

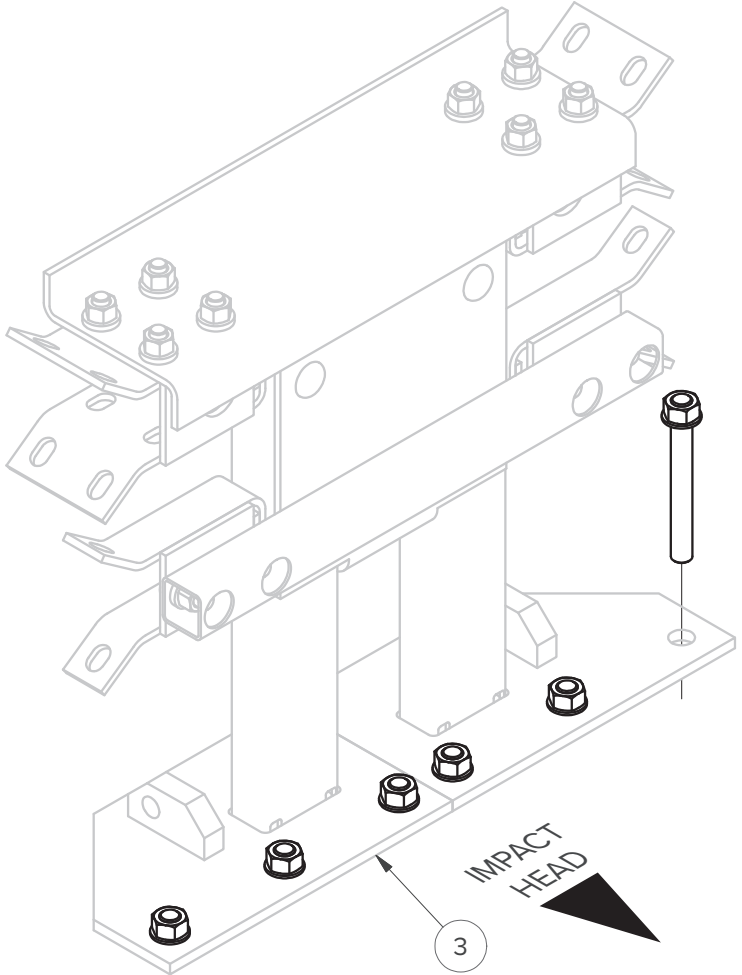
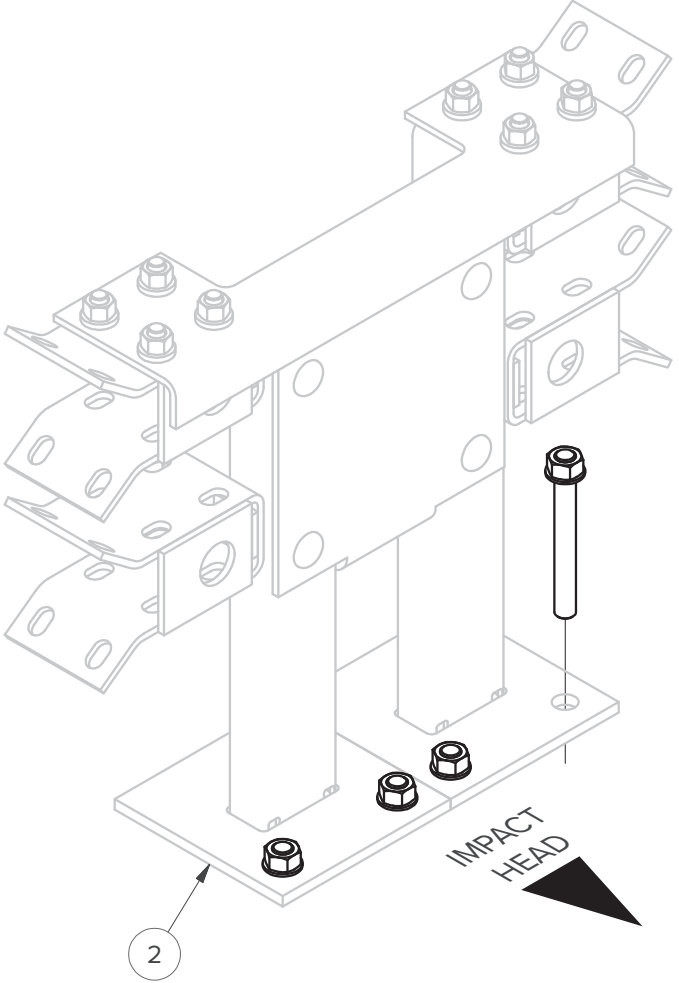

### Step 2 - End Panel & Fender Panel (T3) Assembly

Starting at the rear of the system, install the end panel and T3 fender panels. End panel holes shall be located toward the impact head. Fender panels are labeled for the appropriate bay and the arrow points in the direction of the impact head. A tool may be used in the holes in the front of the panel to hold it in place until the next panel is ready to install.



All side panel and fender fasteners should be finger-tight until all components are assembled.



All rail bolts (M16 x 43) must be fully seated and aligned in the slots.

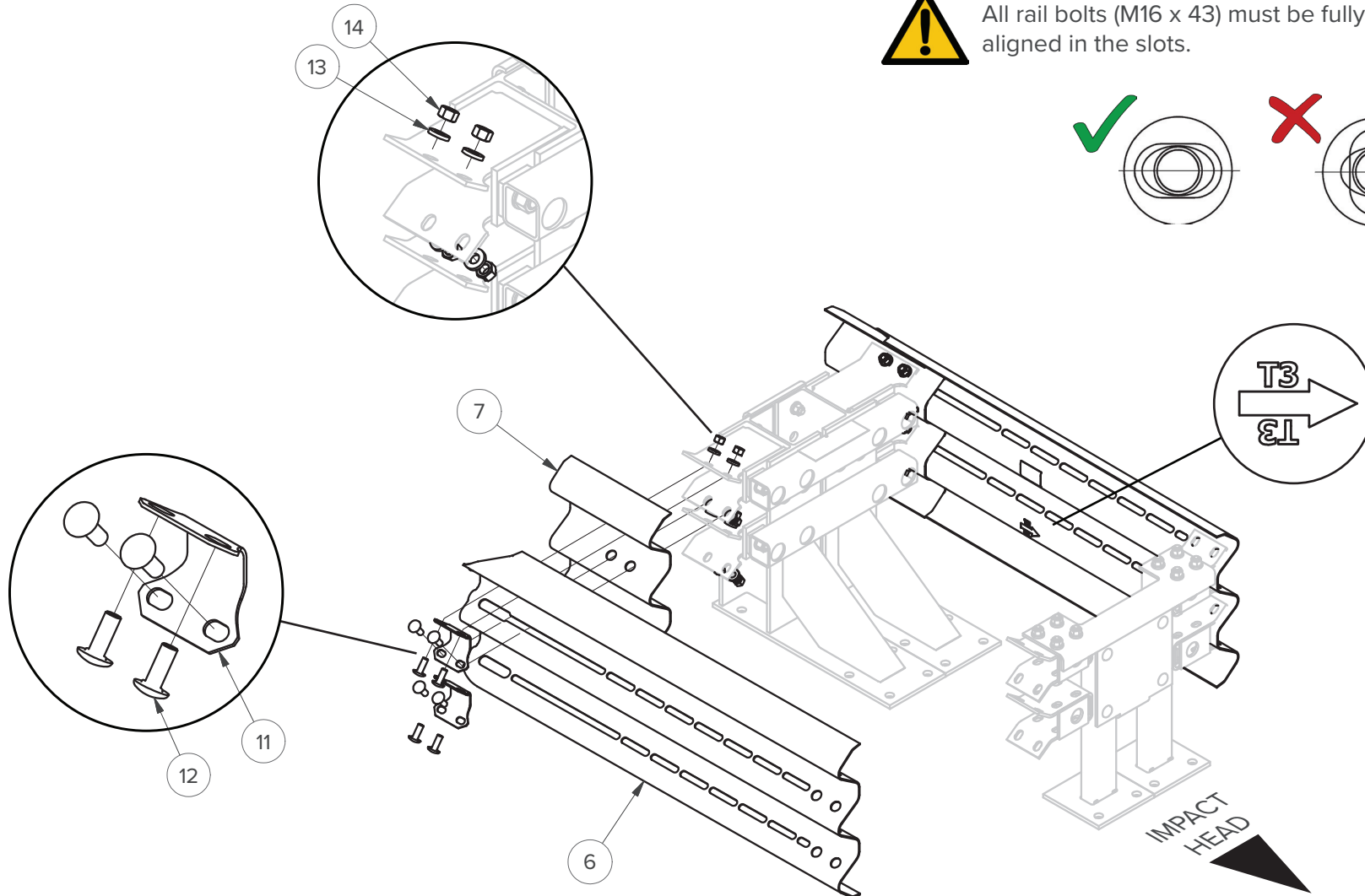



### Step 3 - Fender Panel (T2 - T1) Assembly

Install the remaining fender panels (T2 - T1). Fender panels are labeled for the appropriate bay and the arrow points in the direction of the impact head. A tool may be used in the holes in the front of the panel to hold it in place until the next panel is ready to install.



All side panel and fender fasteners should be finger-tight until all components are assembled.



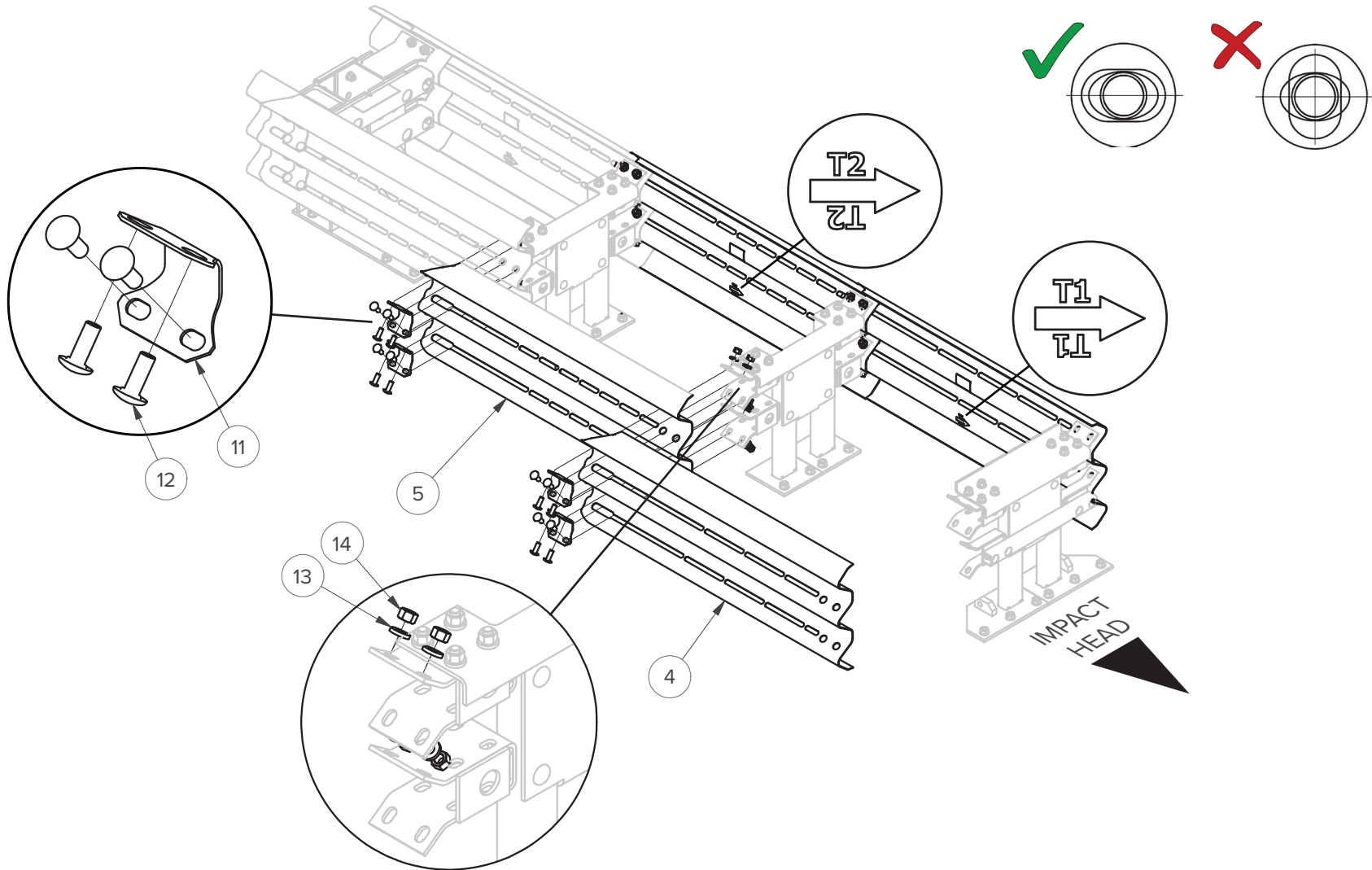

All rail bolts (M16 x 43) must be fully seated and aligned in the slots.

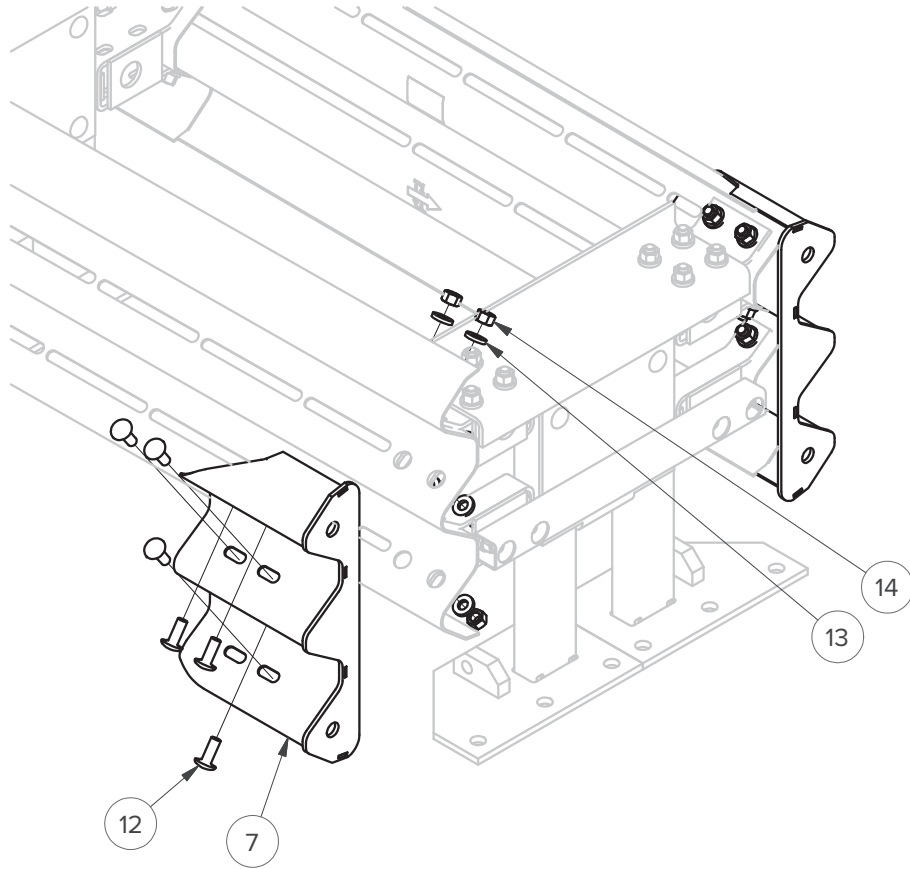

### Step 4 - Head Panel Assembly

Install Head Panels. Note location of M16 fasteners (circled in green). Torque M16 fasteners once all fasteners are installed and finger-tight. Reference the Torque Key for torque values.



TORQUE KEY	
FASTENER SIZE	TORQUE VALUE
 M16	45 N·m ± 2 N·m [33 lb-ft ± 1.5 lb-ft]



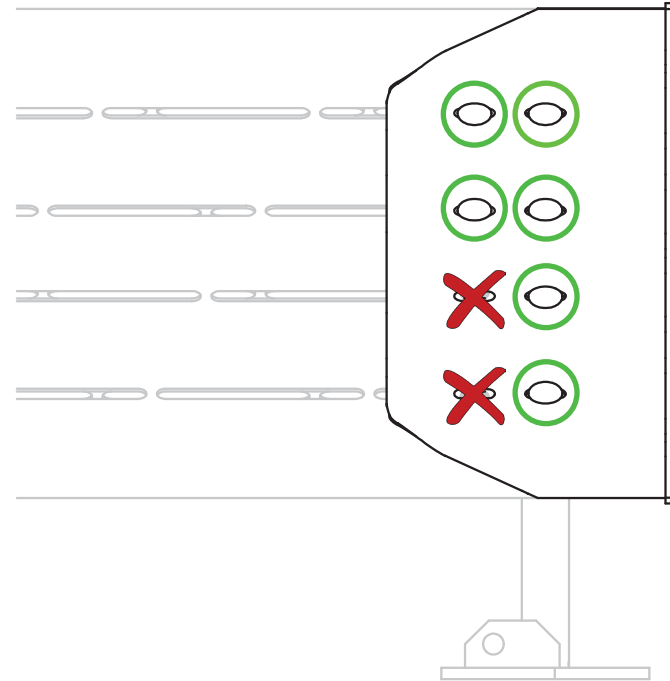
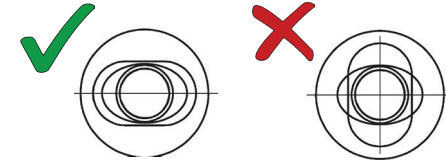

All rail bolts (M16 x 43) must be fully seated and aligned in the slots.

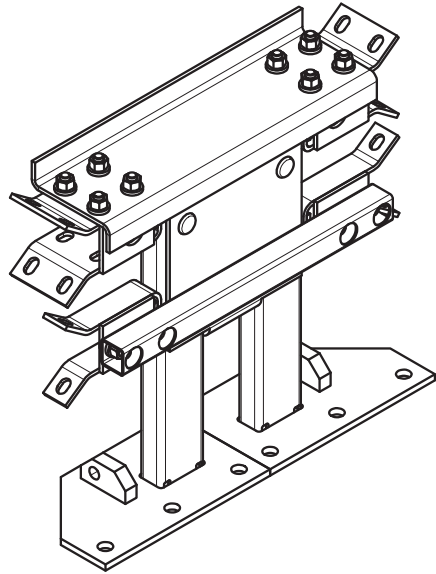

### Step 5 - Front Diaphragm Torque Verification

Verify the torque values for all of the front diaphragm fasteners. Reference the Torque Key for torque values.



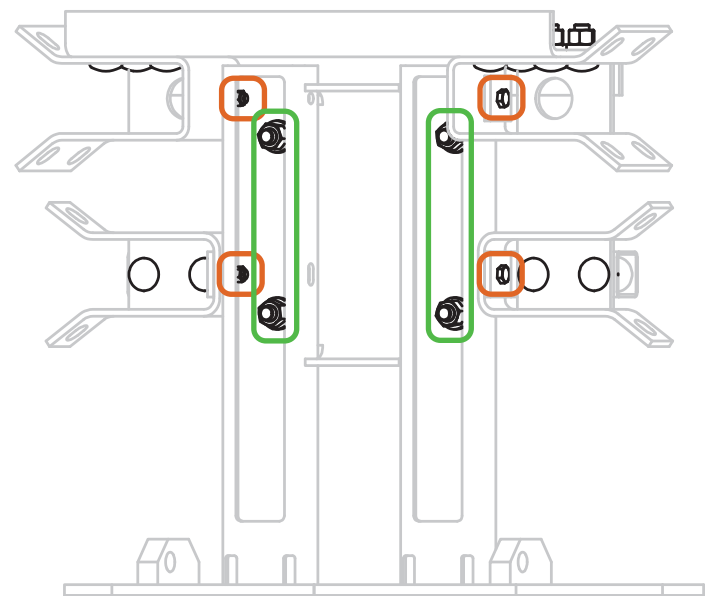
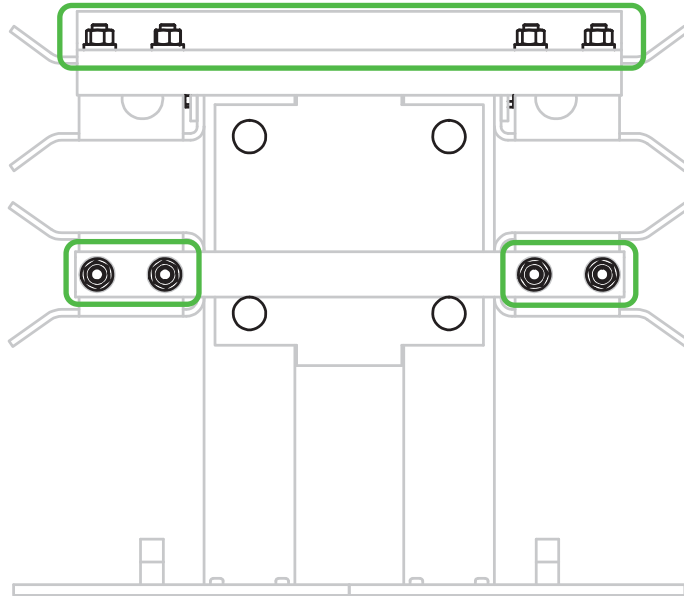

TORQUE KEY	
FASTENER SIZE	TORQUE VALUE
 M10	35 N·m ± 2 N·m [26 lb-ft ± 1.5 lb-ft]
 M16	45 N·m ± 2 N·m [33 lb-ft ± 1.5 lb-ft]



**BACKSIDE VIEW**

## Step 6 - Diaphragm Torque Verification

Verify the torque values for all of the diaphragm fasteners. Reference the Torque Key for torque values.

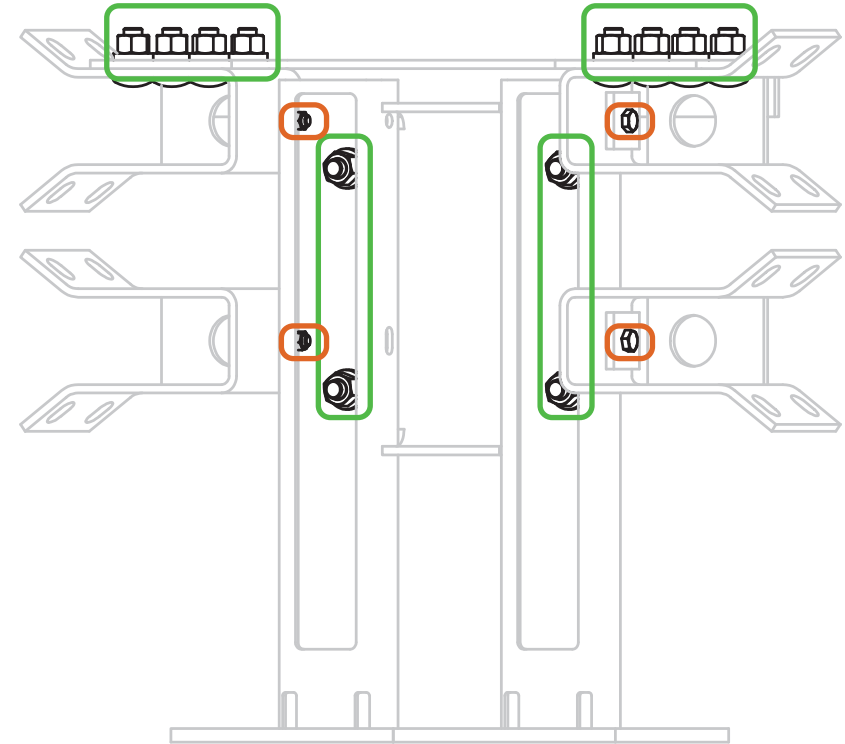
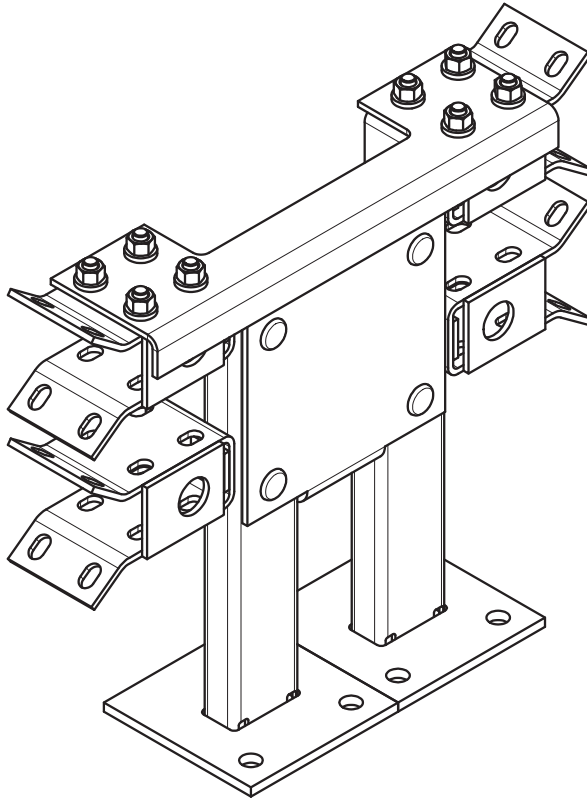

TORQUE KEY	
FASTENER SIZE	TORQUE VALUE
 M10	35 N·m $\pm$ 2 N·m [26 lb-ft $\pm$ 1.5 lb-ft]
 M16	45 N·m $\pm$ 2 N·m [33 lb-ft $\pm$ 1.5 lb-ft]



**BACKSIDE VIEW**

## Step 7 - Backup Torque Verification

Verify the torque values for the backup fasteners. Reference the Torque Key for torque values.

TORQUE KEY	
FASTENER SIZE	TORQUE VALUE
 M16	45 N·m $\pm$ 2 N·m [33 lb-ft $\pm$ 1.5 lb-ft]
 M24	200 N·m $\pm$ 2 N·m [148 lb-ft $\pm$ 4 lb-ft]

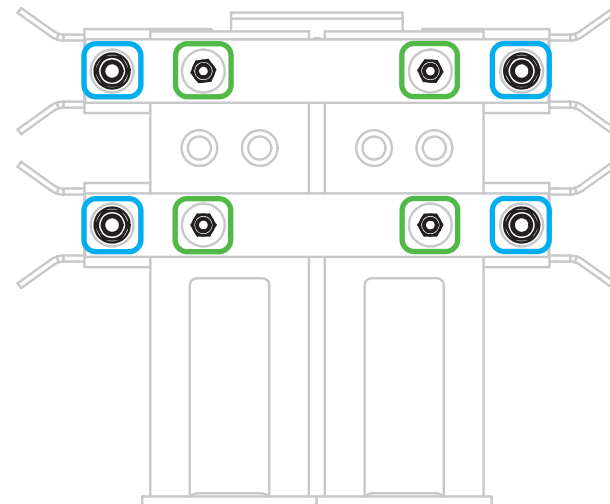
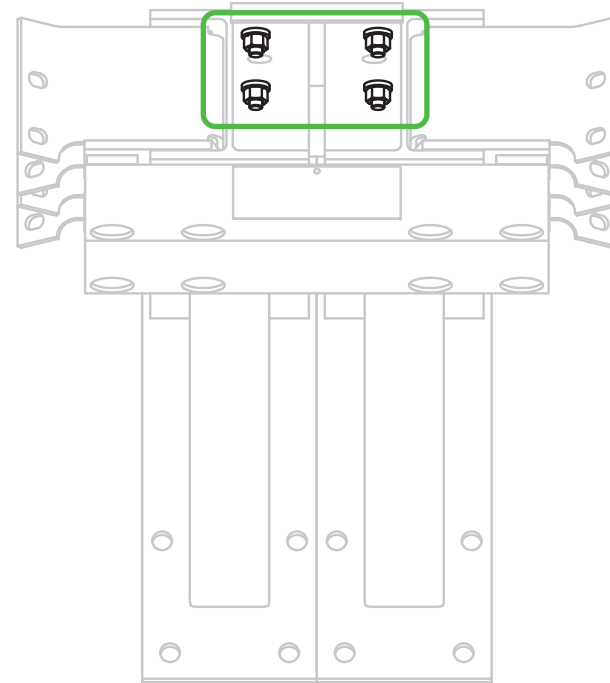
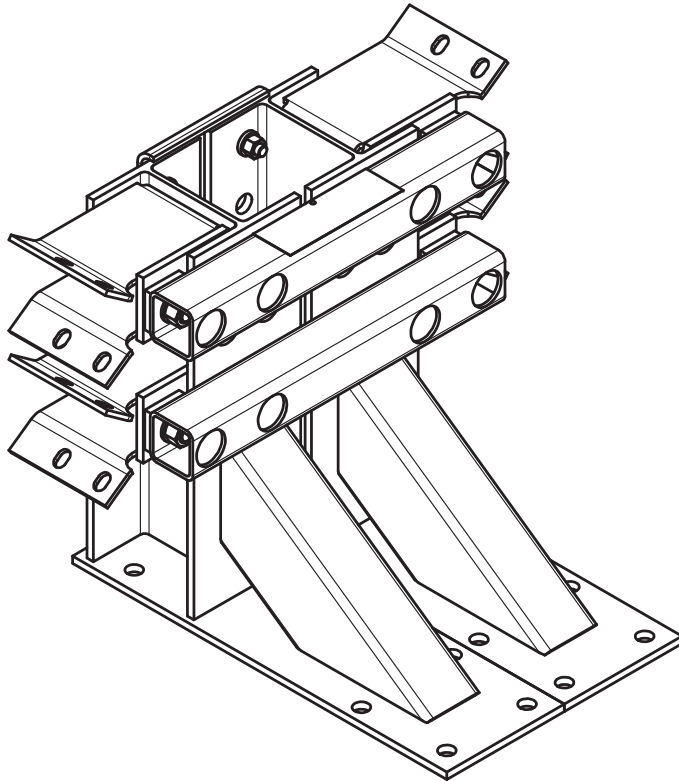

### Step 8 - Impact Head Assembly

Fasten the two impact head panels, tighten and torque M16 fasteners. Attach assembled impact head to the head rail panels using M16 fasteners. Tighten and torque M16 fasteners.

TORQUE KEY	
FASTENER SIZE	TORQUE VALUE
 M16	45 N·m ± 2 N·m [33 lb-ft ± 1.5 lb-ft]

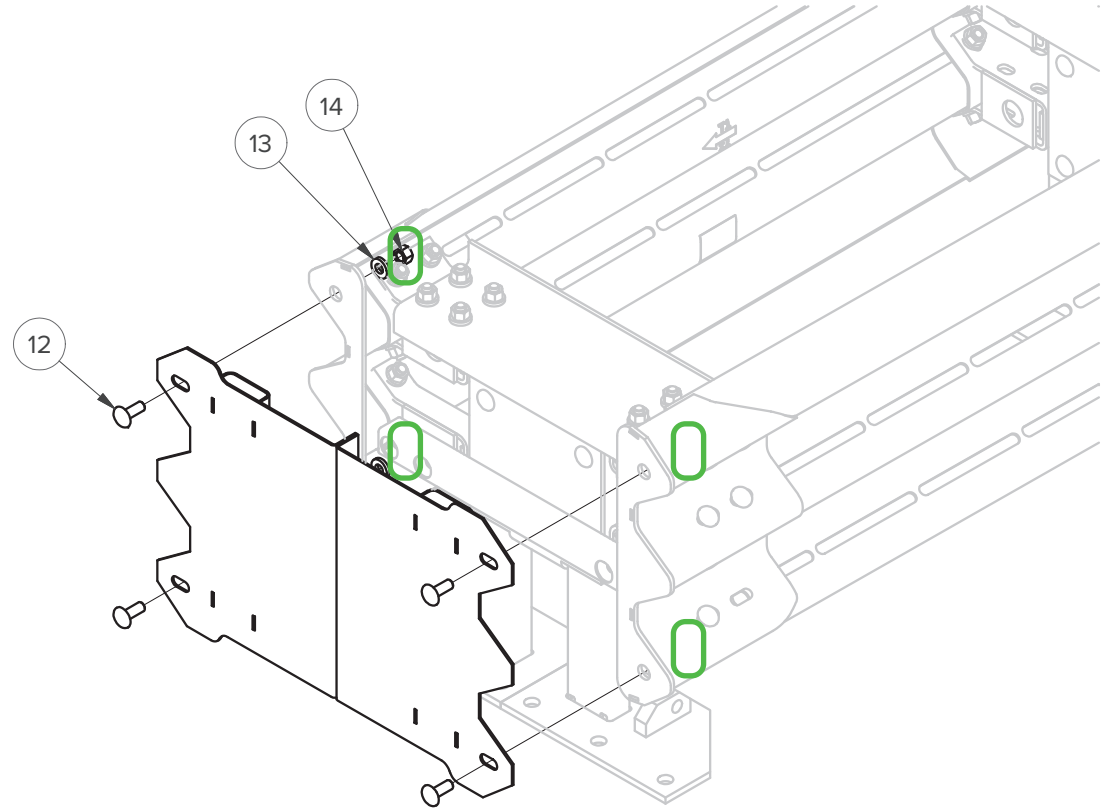
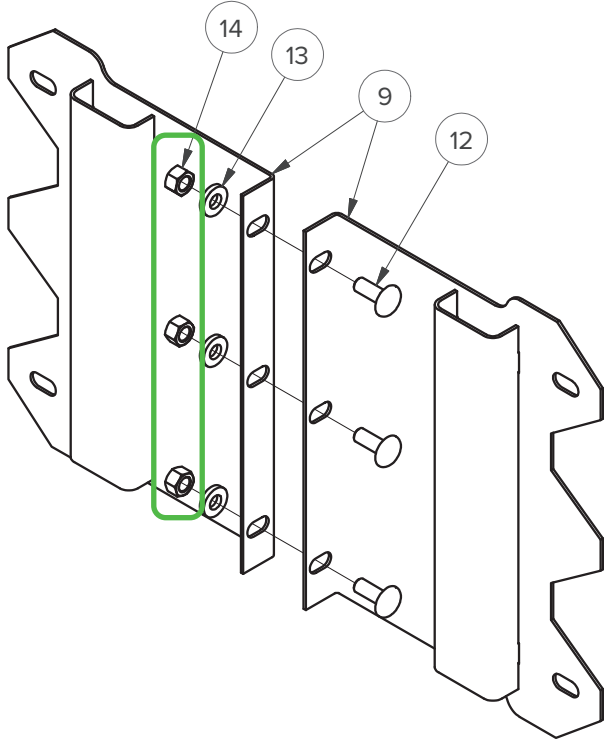

### Step 9 - Panel Fastener Torquing

Ensure all bolts are fully seated and aligned in the slots. Torque all M16 fasteners attaching the fender panels. Refer to Torque Key for torque values.

TORQUE KEY	
FASTENER SIZE	TORQUE VALUE
 M16	45 N·m ± 2 N·m [33 lb-ft ± 1.5 lb-ft]



*Special tools are available to assist with torquing.  
Contact your Valtir sales representative*

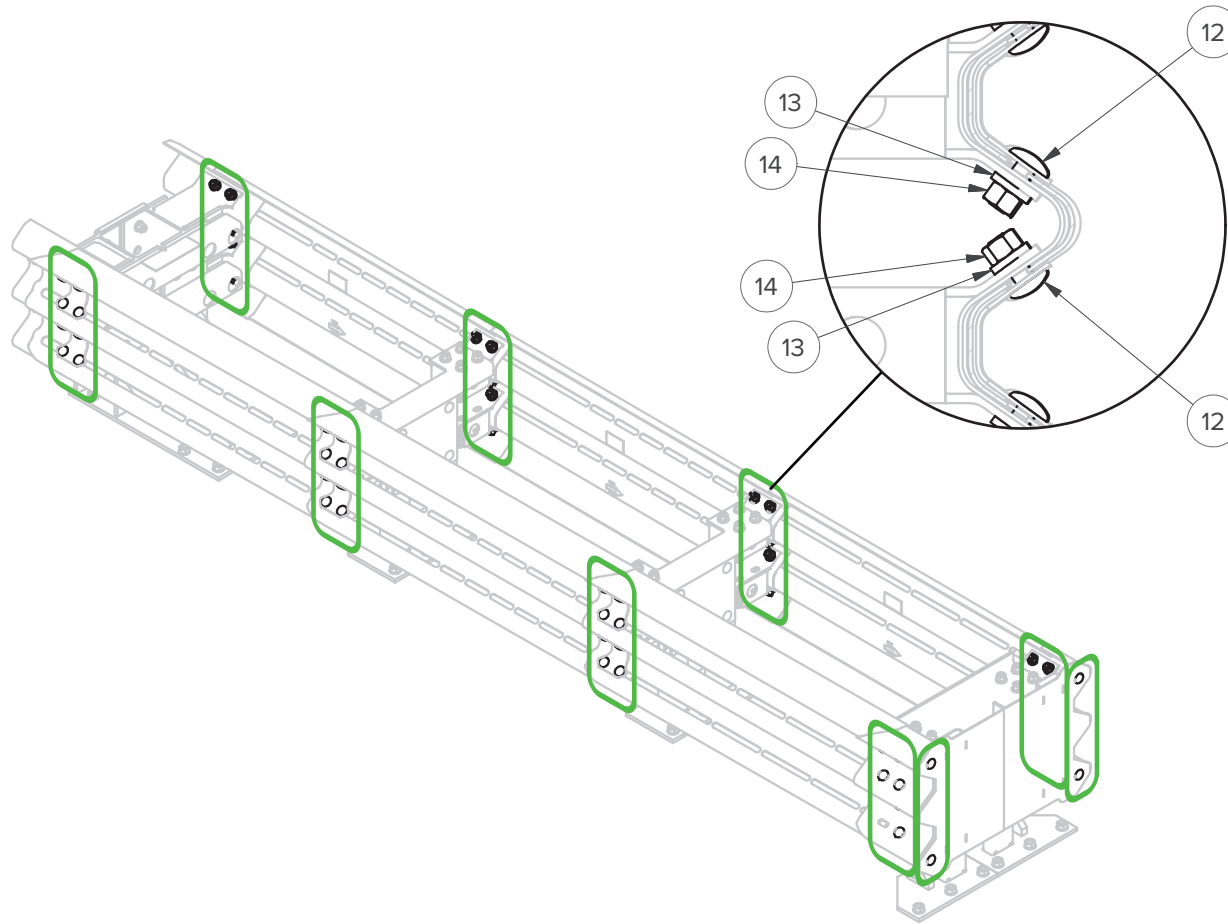

### Step 10 - Cable Assembly

Fasten the cable shackles to the brackets on the front diaphragm, and pass the cables through the holes in the diaphragms and the outer holes in the backup. Tighten and torque the M24 fasteners. Refer to Torque Key for torque values. A pipe wrench may be used to secure the cable ends. See page 31 for an exploded parts list of the cable assembly.

TORQUE KEY	
FASTENER SIZE	TORQUE VALUE
 M24	100 N·m ± 5 N·m [74 lb-ft ± 4 lb-ft]

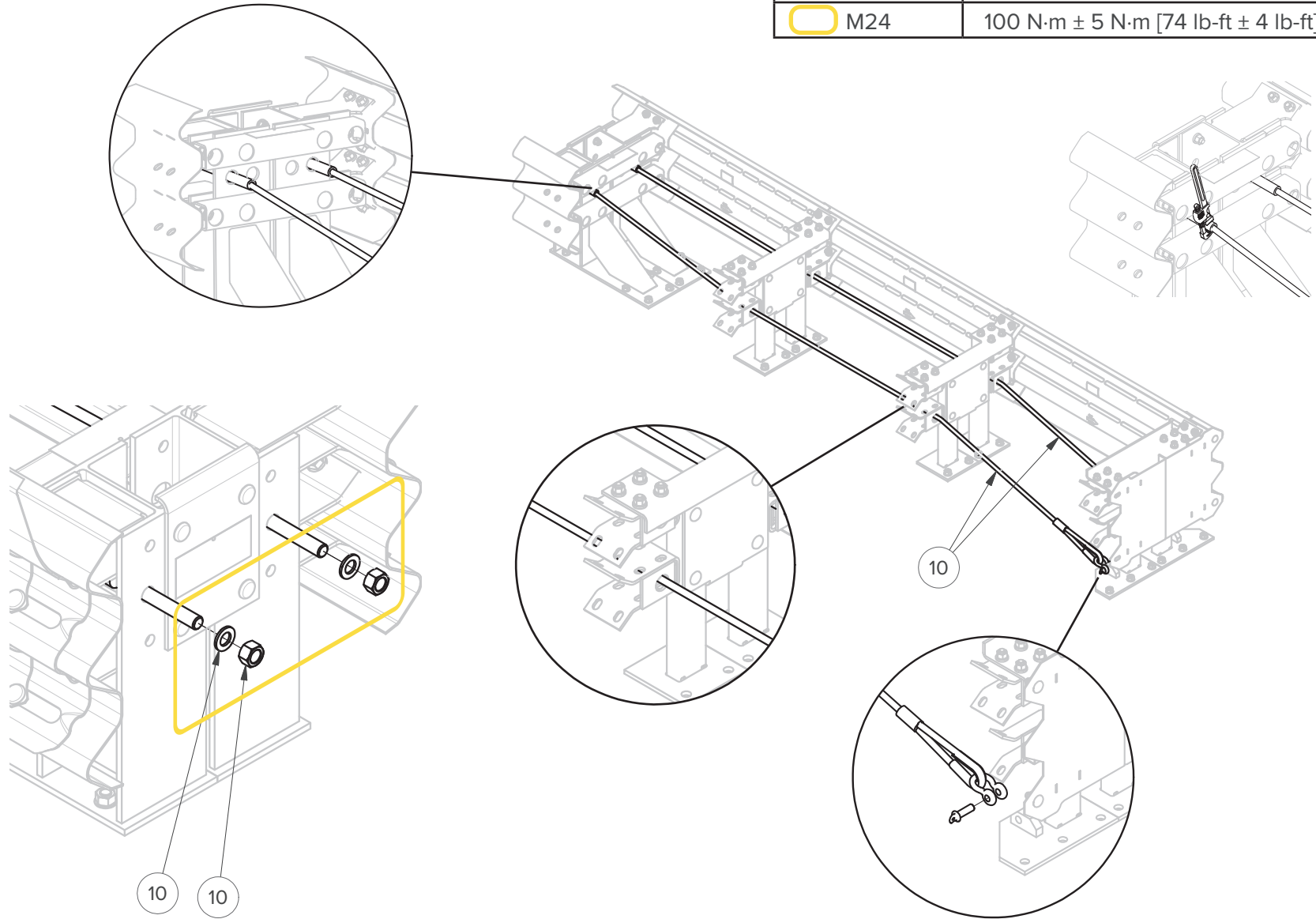

\* Panels removed for clarity



## Assembly Checklist

---

Performed by: \_\_\_\_\_

Date: \_\_\_\_\_

Location: \_\_\_\_\_

- Transitions, if required, are in place and properly fitted.
- Every valid anchor hole on the backup and diaphragms are fastened to the foundation by an anchor.
- Each anchor is properly torqued to the adhesive manufacturer's specifications, where applicable.
- All fasteners are properly aligned and seated in the slots.
- All fasteners are properly torqued.
- Cables are attached and properly tensioned.
- Fender panels are assembled in the correct location and markings are pointing towards the front of the system.
- Remove all construction debris in and around the system.

## Inspection

---

Inspections by the appropriate highway authority are recommended as determined by that authority based upon volume of traffic and impact history. Visual drive-by inspections are recommended at least once a month. Walk-up inspections are recommended at least every two years.

### Visual Drive-By Inspection

1. Inspect for impact, misalignment, missing fasteners, corrosion, vandalism, or any other damage
2. Record the date, location, and system location.

A Walk-Up is required if any of the above are detected.



Debris, snow, or ice inside the CENTRA™ 610 80K system may prevent the system from properly absorbing the impact of a crash. Perform a walk-up inspection as needed to check for and remove any debris inside or around the system.

### Walk-Up Inspection

- Remove debris found under and around the system.
- All fasteners are tight and rust free.
- Anchor studs are securely anchored.
- Fender panel fasteners are properly torqued.
- Cables are tensioned and properly torqued.
- Transitions are properly attached (if applicable).
- Note the location and condition of the system and any work done for the date of this inspection. If further repair is necessary, note the repair requested.
- Replace all damaged parts.

Inspection Log

Location: \_\_\_\_\_

System Serial Number: \_\_\_\_\_

Date	Inspector	Condition	Maintenance Actions

# Parts List

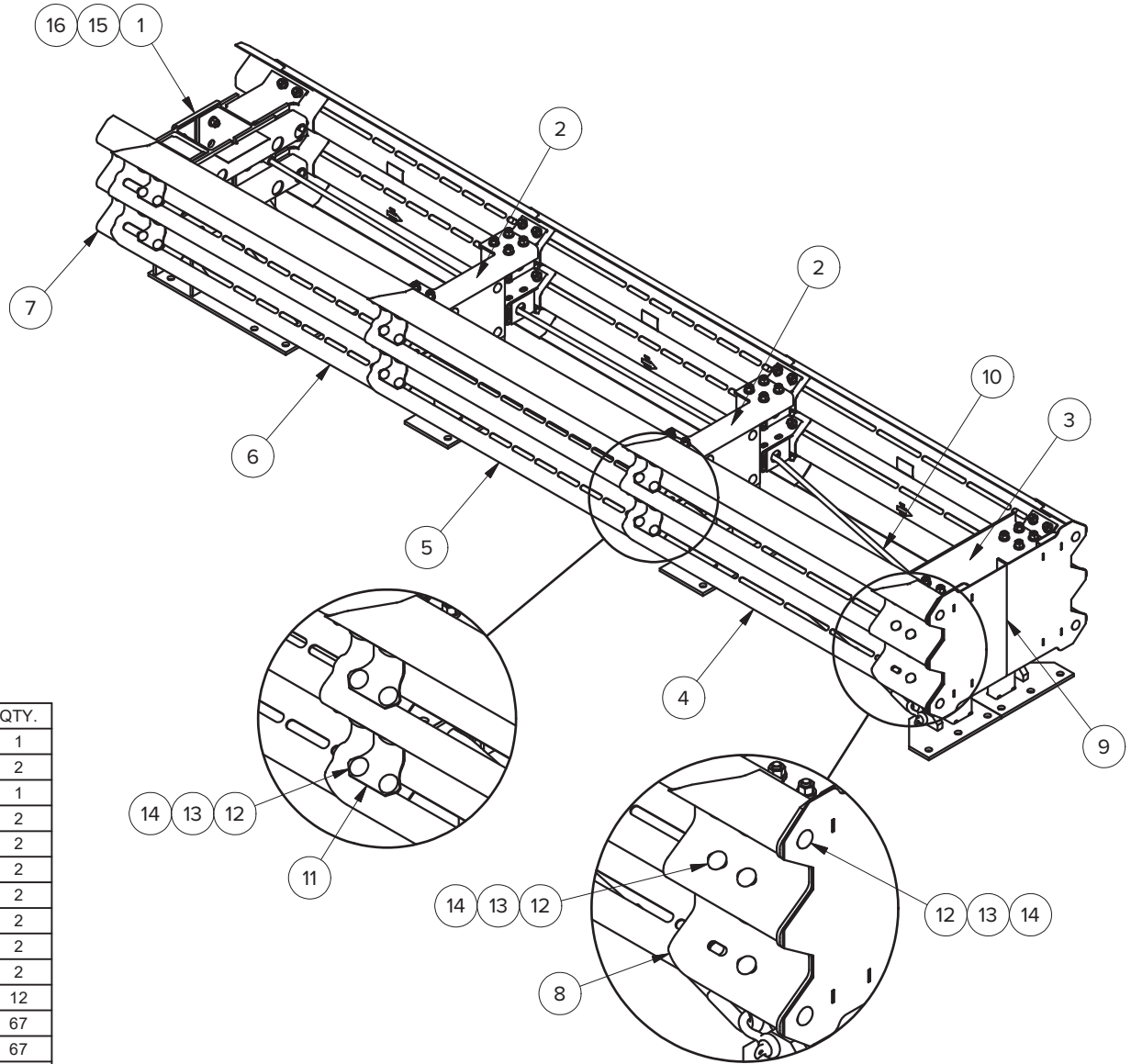

ITEM	PART NO.	DESCRIPTION	QTY.
1	627373	BACKUP ASSEMBLY,CENTRA 610	1
2	627051	DIAPHRAGM ASSEMBLY	2
3	627060	FRONT DIAPHRAGM ASSEMBLY	1
4	627062	FENDER PANEL,TYPE 1,W/DECAL	2
5	627064	FENDER PANEL,TYPE 2,W/DECAL	2
6	627066	FENDER PANEL,TYPE 3,W/DECAL	2
7	627093	PANEL,END,80,G	2
8	627079	RAIL ASSY,HEAD,G	2
9	627076	IMPACT HEAD,HALF ASSY	2
10	627094	CABLE ASSY,W/SHACKLE,4042	2
11	627080	BACKING PLATE,G	12
12	119126	BOLT,RAIL,M16X2X43,8.8,G	67
13	627050	WASHER,FLAT,M16,6mm THICK,G	67
14	116011	NUT,HX,M16X2,10,G	67
15	118437	TACK,METAL,1/4	1
16	119610	DECAL,APPROVALS,CENTRA,80	1

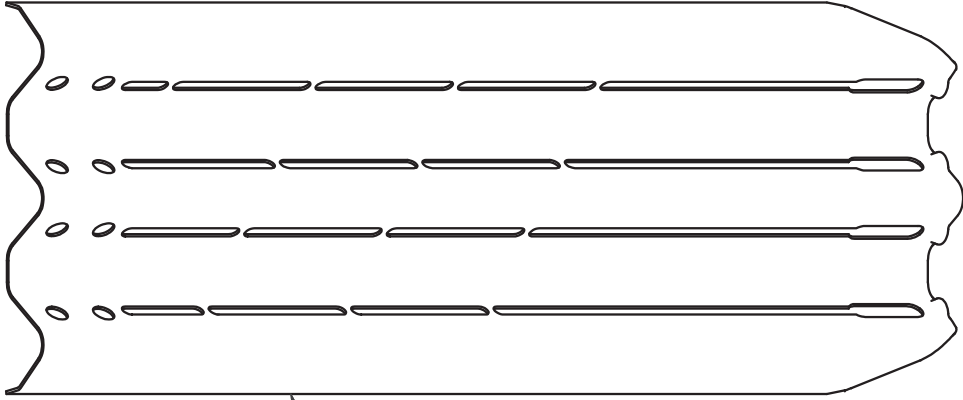

4 T1 Fender Panel

5 T2 Fender Panel

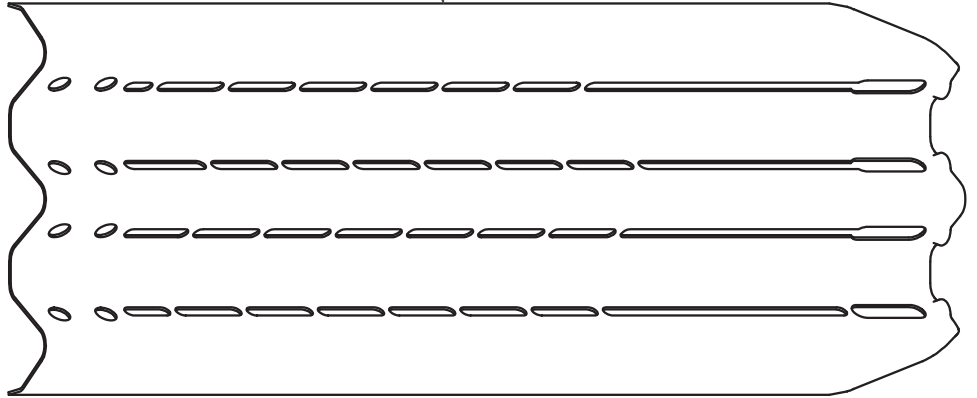

6 T3 Fender Panel

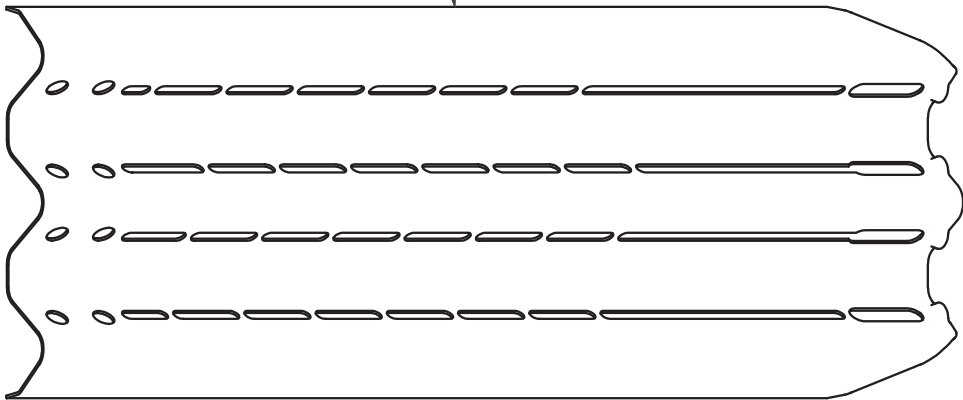

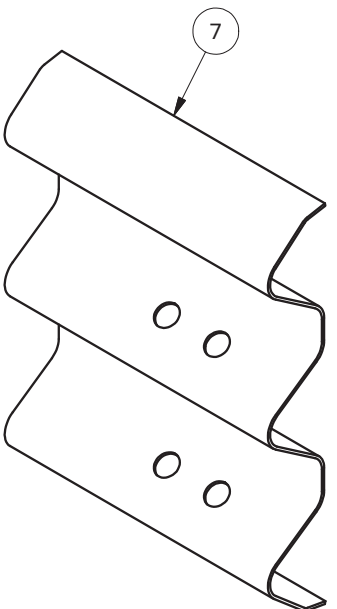
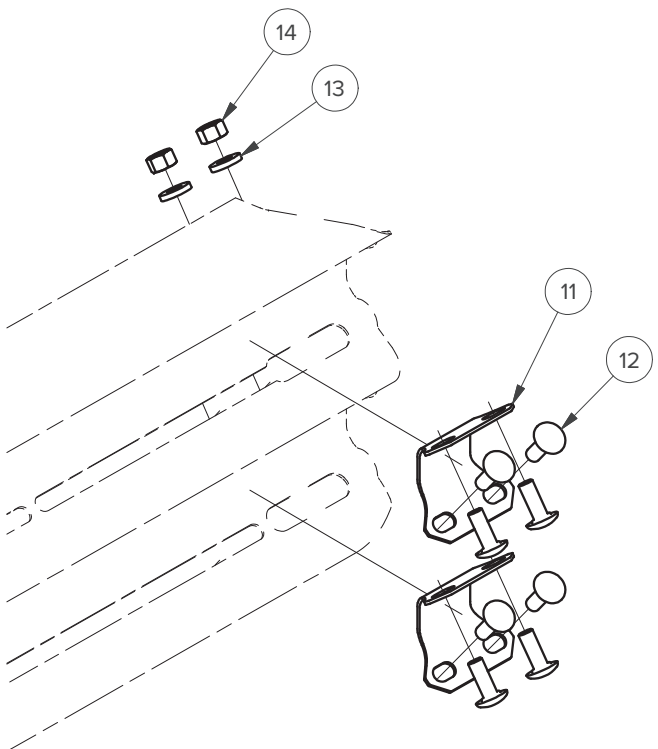

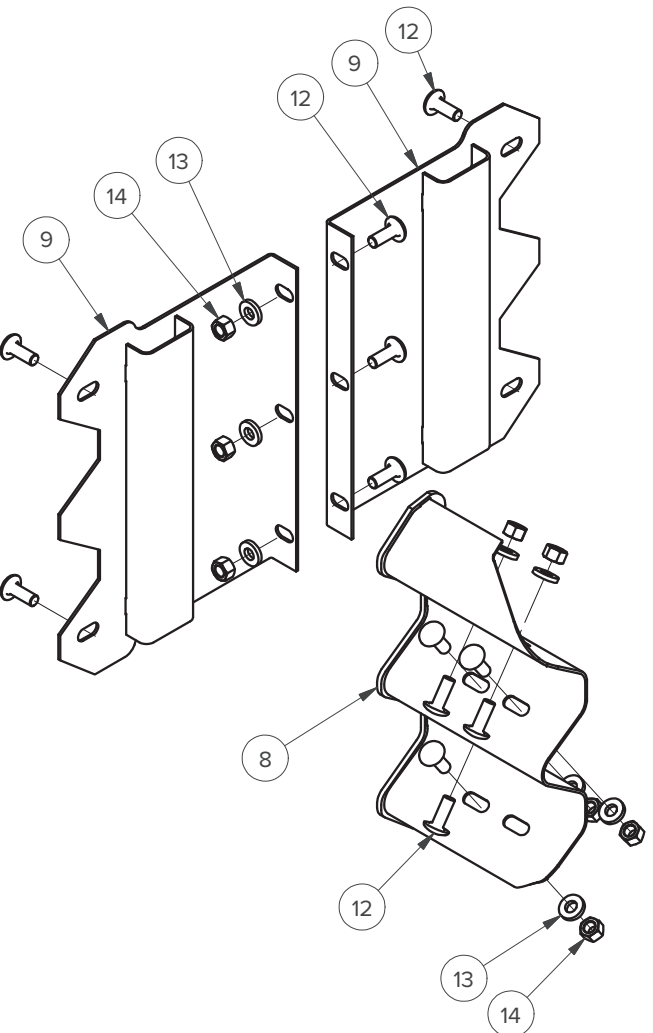
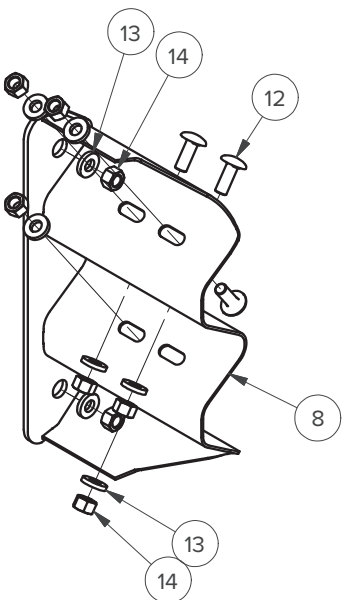

## Sub Assembly - Backup (P/N - 627373)

PARTS LIST			
ITEM	PART NO.	DESCRIPTION	QTY
1	628335	MODULAR BACKUP	2
2	627081	BACKUP,CROSS BAR	1
3	627082	TS 80X80X6X584,W/HOLES	2
4	627083	FLT 12X64X64,W/HOLE	4
5	627086	SPACER,BACKUP ASSY	4
6	120106	BOLT,HEX,M24X3X60,10.9,G	4
7	116011	NUT,HX,M16X2,10,G	8
8	113703	BOLT,SPLICE,M16X50,8.8,G	8
9	118067	WASHER,FLAT,M24,G	4
10	627050	WASHER,FLAT,M16,6mm	4
11	116015	NUT,HX,M24X3,8.8,G	4

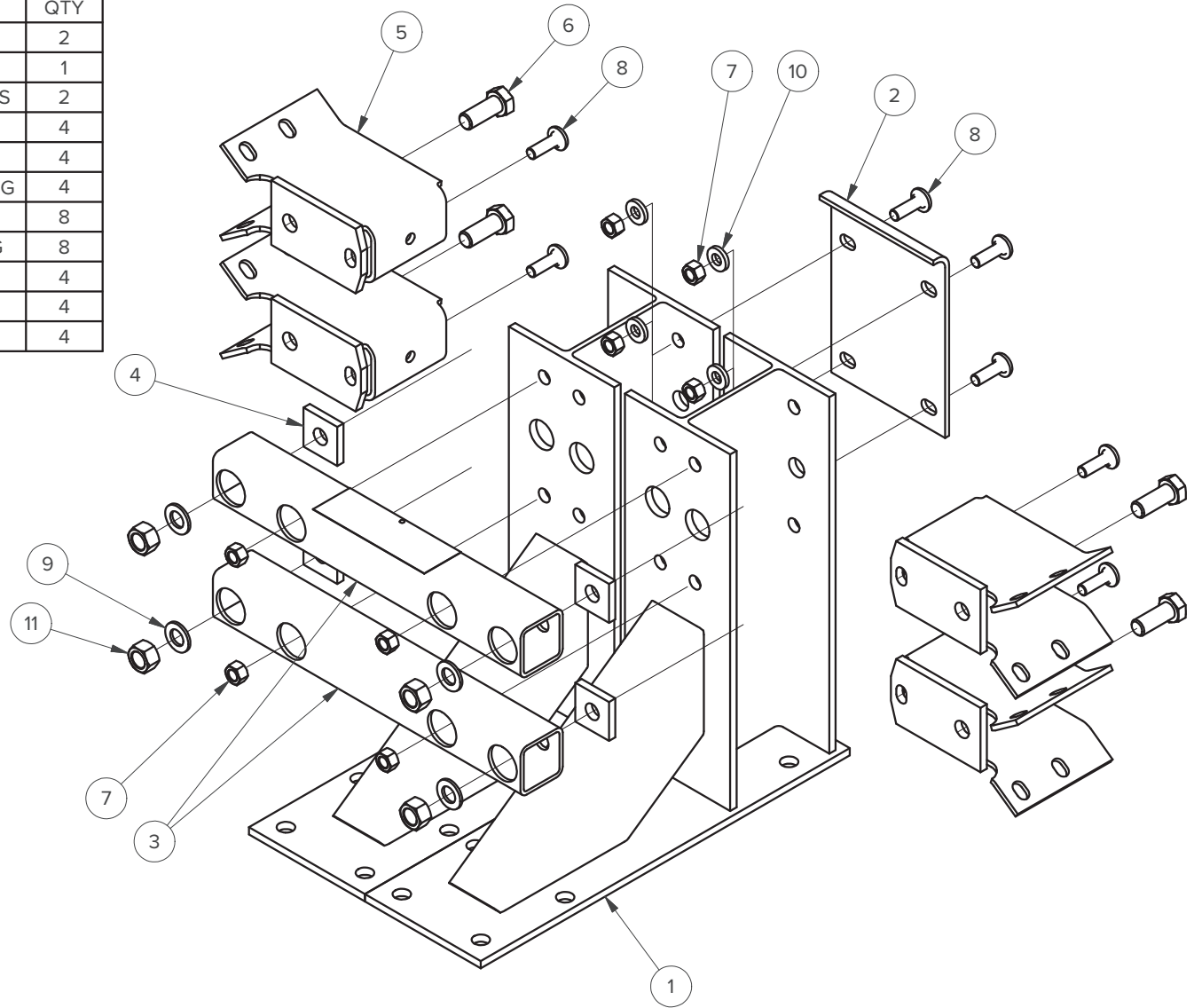

## Sub Assembly - Diaphragm (P/N - 627051)

PARTS LIST			
ITEM	PART NO.	DESCRIPTION	QTY
1	627043	MODULAR DIAPHRAGM,G	2
2	627046	SPACER ASSY,WIDE	4
3	627047	DIAPHRAGM CROSS BAR,TALL,450	1
4	627048	TOP STIFFENER	1
5	627049	WASHER,BAR,7.5X50X50,W/HOLE	4
6	120105	BOLT,HX,M10X1.5X35,4.8,G	4
7	118060	WASHER,FLAT,M10,G	4
8	116007	NUT,HX,M10X1.5,8,G	4
9	119126	BOLT,RAIL,M16X2X43,8.8,G	12
10	627050	WASHER,FLAT,M16,6mm THICK,G	12
11	116011	NUT,HX,M16X2,10,G	12

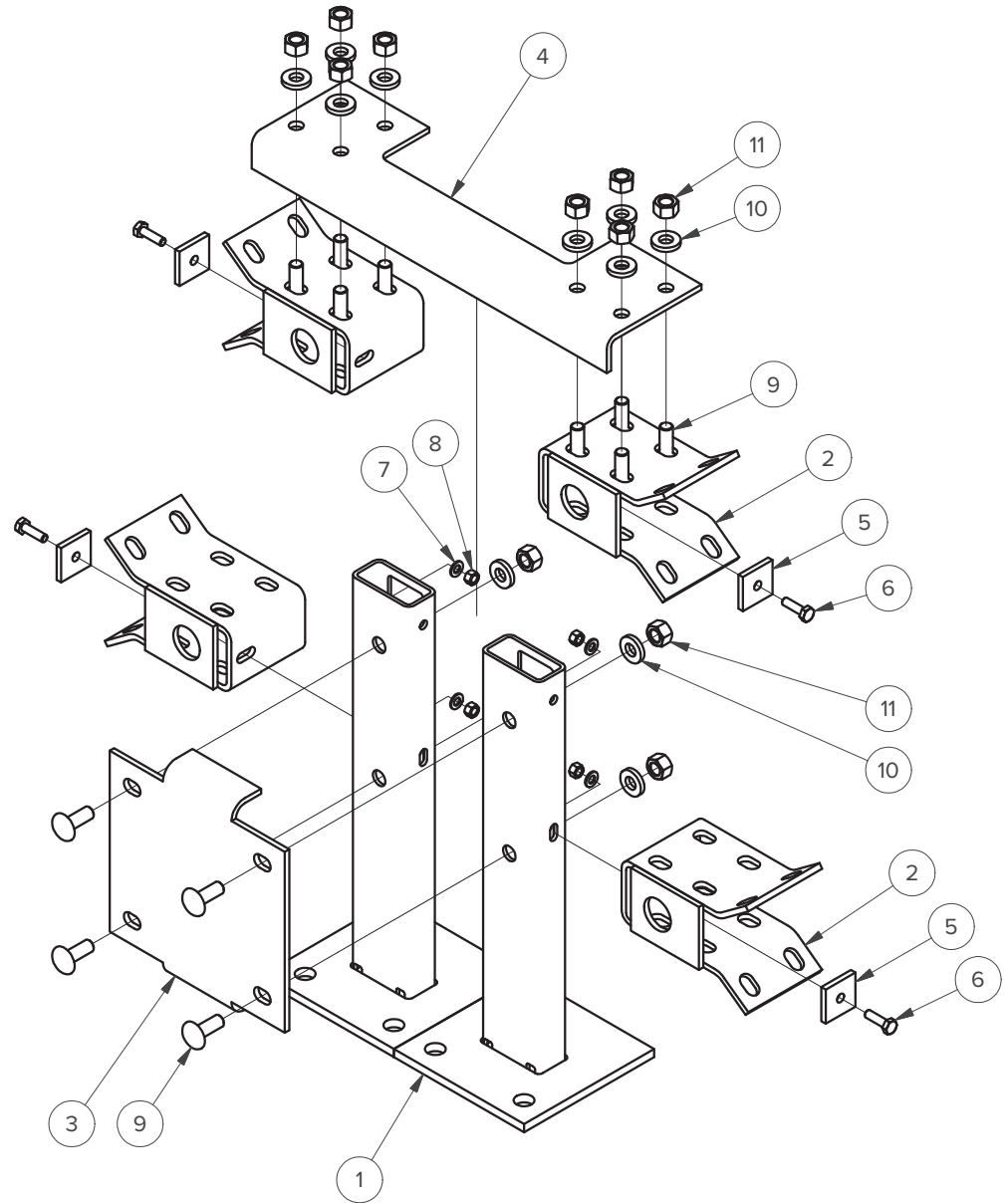



## Sub Assembly - Front Diaphragm (P/N - 627060)

PARTS LIST			
ITEM	PART NO.	DESCRIPTION	QTY
1	627053	MODULAR DIAPHRAGM,RIGHT	1
2	627054	MODULAR DIAPHRAGM,LEFT	1
3	627057	SPACER ASSEMBLY,G	2
4	627046	SPACER ASSY,WIDE	2
5	627058	TS 50X50X3X605,W/HOLES	1
6	627047	DIAPHRAGM CROSS BAR,TALL,450	1
7	627059	TOP STIFFENER,FRONT DIAPHRAGM	1
8	627049	WASHER,BAR,7.5X50X50,W/HOLE	4
9	120105	BOLT,HX,M10X1.5X35,4.8,G	4
10	118060	WASHER,FLAT,M10,G	4
11	116007	NUT,HX,M10X1.5,8,G	4
12	119126	BOLT,RAIL,M16X2X43,8.8,G	16
13	627050	WASHER,FLAT,M16,6mm THICK,G	16
14	116011	NUT,HX,M16X2,10,G	16

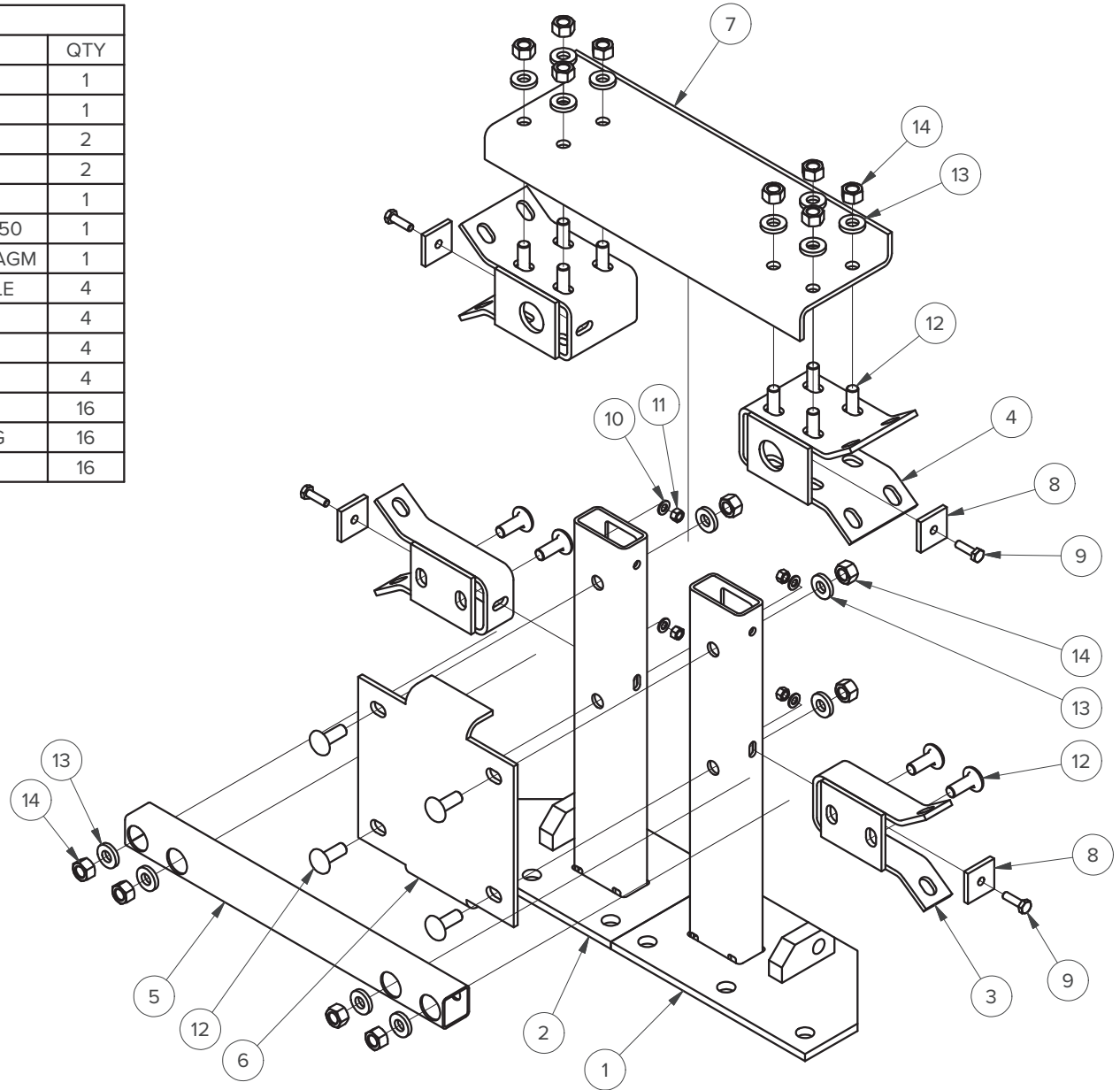

### Sub Assembly - Cable (P/N - 627094)

ITEM	PART NO.	DESCRIPTION	QTY.
1	119558	CABLE,4042,TE	2
2	117071	SHACKLE,ANCHOR,5/8,W/SCREW PIN	2
3	118067	WASHER,FLAT,M24,G	2
4	116015	NUT,HX,M24X3,8.8,G	2

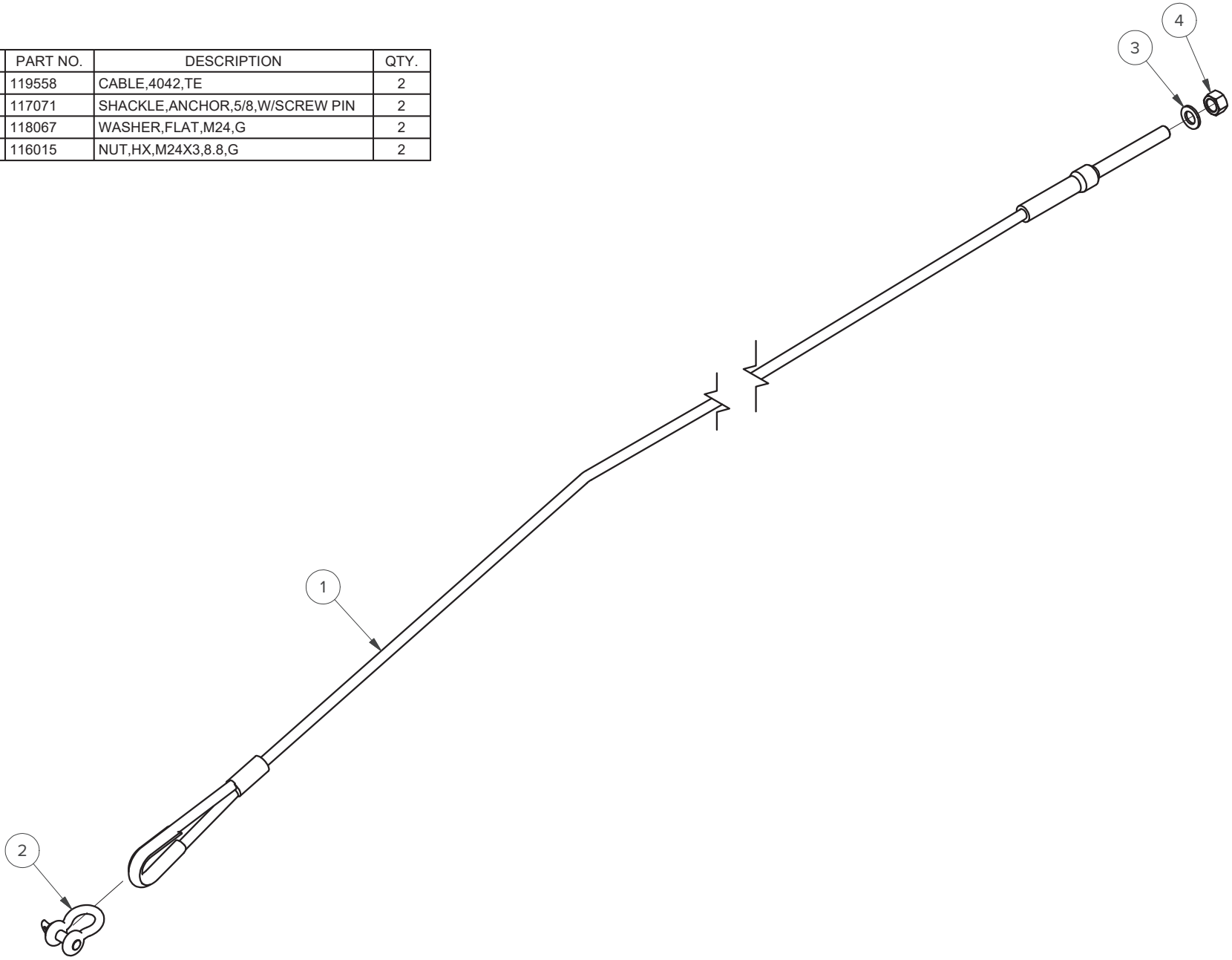





USA Headquarters  
**+1-214-589-8140**

Europe  
**+44 7361 864735**

Middle East - Africa  
**+46 709 66 10 55**

Asia - Pacific - AUS - NZ  
**+1-214-589-8140**

Canada  
**+1-214-589-8284**

Caribbean - Latin America  
**+1-916-644-9108**

**[WWW.VALTIR.COM](http://WWW.VALTIR.COM)**

For more complete information on Valtir products and services, visit us on the web at [www.valtir.com](http://www.valtir.com). Materials and specifications are subject to change without notice. Please contact Valtir to confirm that you are referring to the most current instructions.