

# Energite® III Fitch® Universal Module Systems

## Assembly and Maintenance Manual



15601 Dallas Parkway  
Suite 525  
Addison, Texas 75001



**Important:** These instructions are to be used only in conjunction with the assembly, maintenance, and repair of the Energite® III/Fitch® Universal Module Systems. These instructions are for standard assembly specified by the appropriate highway authority only. In the event the specified system assembly, maintenance, or repair would require a deviation from standard assembly parameters, contact the appropriate highway authority engineer. This system has been accepted for use by the Federal Highway Administration for use on the national highway system under strict criteria utilized by that agency. Valtir representatives are available for consultation if required.

**This Manual must be available to the worker overseeing and/or assembling the product at all times. For additional copies, contact Valtir at (888) 356-2363 or download from websites below.**

The instructions contained in this Manual supersede all previous information and Manuals. All information, illustrations, and specifications in this Manual are based on the latest Energite® III/Fitch® Universal Module Systems information available to Valtir at the time of printing. We reserve the right to make changes at any time. Please contact Valtir to confirm that you are referring to the most current instructions.

## **Table of Contents**

Customer Service Contacts .....	3
Important Introductory Notes .....	3
Recommended Safety Rules for Assembly .....	4
Safety Symbols .....	5
Warnings and Cautions.....	5
Limitations and Warnings.....	5
Important Introductory Notes .....	7
System Overview .....	8
Recommended Tools .....	9
Site Preparation/Foundation .....	10
Inspect Shipment .....	10
Assembly .....	11
Alternate Assembly Option .....	15
Checking the Assembled System .....	16
Maintenance Checklist.....	16
Visual Drive-By Inspection Checklist.....	16
Walk-Up Inspections Checklist.....	17
Refurbishment Procedures .....	18
Alternate Refurbishment Option.....	19
Maintenance Log.....	20

## **Customer Service Contacts**

Valtir (a Valtir company) is committed to the highest level of customer service. Feedback regarding the Energite® III/Fitch® Universal Module Systems, its assembly procedures, supporting documentation, and performance is always welcome. Additional information can be obtained from the contact information below:

### **Valtir:**

Telephone:	(888) 356-2363 (USA) (214) 589-8140 (International)
Fax:	(800) 770-6755 (USA) (214) 589-8423 (International)
Internet:	<a href="http://www.valtir.com">www.valtir.com</a>

## **Important Introductory Notes**

Proper assembly of the Energite® III/Fitch® Universal Module Systems is essential to achieve performance of the system under appropriate federal and state criteria. These instructions should be read in their entirety and understood before assembling the Energite® III/Fitch® Universal Module Systems. These instructions are to be used only in conjunction with the assembly of the Energite® III/Fitch® Universal Module Systems and are for standard assemblies only as specified by the applicable highway authority. In the event your system assembly requires or involves deviation from standard parameters or, during the assembly process a question arises, please contact the appropriate highway authority that specified this system at this particular location for guidance. Valtir is available for consultation with that agency. These instructions are intended for an individual who is qualified to both read and accurately interpret them as written. They are intended for the individual who is experienced and skilled in the assembly of highway products which are specified and selected by the highway authority.

A set of product and project shop drawings will be supplied by Valtir. The shop drawings will be for each section of the assembly. These drawings should be reviewed and studied thoroughly by a qualified individual who is skilled in interpreting them before the start of any assembly.



**Important:** Read safety instructions thoroughly and follow the assembly directions and suggested safe practices before assembling, maintaining, or repairing the Energite® III/Fitch® Universal Module Systems. Failure to follow this warning can result in serious injury or death to workers and/or bystanders. It further compromises the acceptance of this system by the FHWA. Please keep these instructions for later use.



**Warning:** Ensure that all of the Energite® III/Fitch® Universal Module Systems Warnings, Cautions, and Important statements within the Energite® III/Fitch® Universal Module Systems Manual are completely followed. Failure to follow this warning could result in serious injury or death.

## **Recommended Safety Rules for Assembly**

### **\* Important Safety Instructions \***

This Manual must be kept in a location where it is readily available to persons who are skilled and experienced in the assembly, maintenance, or repair of the Energite® III/Fitch® Universal Module Systems. Additional copies of this Manual are available from Valtir by calling (888) 356-2363 or online at [www.valtir.com](http://www.valtir.com). This Manual may also be downloaded directly from the websites indicated below. Please contact Valtir if you have any questions concerning the information in this Manual or about the Energite® III/Fitch® Universal Module Systems.

Always use appropriate safety precautions when operating power equipment, mixing chemicals, and when moving heavy equipment or the Energite® III/Fitch® Universal Module Systems components. Gloves, safety goggles, steel toe boots, and back protection shall be used.

Safety measures incorporating traffic control devices specified by the highway authority must be used to provide safety for personnel while at the assembly, maintenance, or repair site.

## Safety Symbols

This section describes the safety symbols that appear in this Energite® III/Fitch® Universal Module Systems Manual. Read the Manual for complete safety, assembly, operating, maintenance, repair, and service information.

<u>Symbol</u>	<u>Meaning</u>
---------------	----------------



**Safety Alert Symbol:** Indicates Danger, Warning, or Caution. Failure to read and follow the Danger, Warning, Safety, or Caution indicators could result in serious injury or death to the workers and/or bystanders.

## Warnings and Cautions

Read all instructions before assembling, maintaining, or repairing the Energite® III/Fitch® Universal Module Systems.



**Warning:** Do not assemble, maintain, or repair the barrier system until you have read this Manual thoroughly and completely understand it. Ensure that all Warnings, Cautions, and Important Statements within the Manual are completely followed. Please call Valtir at (888) 356-2363 if you do not understand these instructions. Failure to follow this warning could result in serious injury or death.



**Warning:** Safety measures incorporating appropriate traffic control devices specified by the highway authority must be used to protect all personnel while at the assembly, maintenance, or repair site. Failure to follow this warning could result in serious injury or death.



**Warning:** Use only Valtir parts that are specified herein for the Energite® III/Fitch® Universal Module Systems for assembling, maintaining, or repairing the Energite® III/Fitch® Universal Module Systems. Do not utilize or otherwise comeingle parts from other systems even if those systems are other Valtir systems. Such configurations have not been tested, nor have they been accepted for use. Assembly, maintenance, or repairs using unspecified parts or accessories is strictly prohibited. Failure to follow this warning could result in serious injury or death in the event of a vehicle impact with an UNACCEPTED system.



**Warning:** Do NOT modify the barrier system in any way. Failure to follow this warning could result in serious injury or death in the event of a collision.



**Warning:** Ensure that the barrier system and delineation used meet all federal, state, specifying agency, and local specifications. Failure to follow this warning could result in serious injury or death in the event of a collision.



**Warning:** Ensure that your assembly meets all appropriate Manual on Uniform Traffic Control Devices (MUTCD) and local standards. Failure to follow this warning could result in serious injury or death in the event of a collision.

## Limitations and Warnings

The Energite® III/Fitch® Universal Module systems have been tested and evaluated per recommendations of the National Cooperative Highway Research Program (NCHRP) Report 350\* for Test Level 3, gating, and non-redirective impact conditions. The Energite® III/Fitch® Universal Module systems, as currently designed with the proper array, have been shown in federally approved crash testing to be capable of decelerating and stopping light and heavy weight vehicles (820 to 2000 kg, 1810 to 4410 lbs.) when impacted head-on or at angles from 0 degrees to 15 degrees and at 100 km/h (62 mph). Tests were conducted on slopes less than 5% and without curbs.

The Energite® III/Fitch® Universal Module Systems are non-redirective crash cushions and should be used appropriately.

Curbs may create a vehicle ramping condition which could cause an untested effect on the impacting vehicle. Therefore, do not assemble this product on or near curbs.

Valtir, in compliance with the National Cooperative Research Highway Program 350 (NCHRP Report 350) "Recommended Procedures for the Safety Performance of Highway Safety Features", contracts with FHWA approved testing facilities to perform crash tests, evaluation of tests, and submittal of results to the Federal Highway Administration for review.

The Energite® III/Fitch® Universal Module Systems was tested to meet the impact criteria, requirements, and guidelines of NCHRP Report 350. These tests, specifically set forth by FHWA, evaluate product performance by simulating those impacts outlined by NCHRP Report 350 involving a typical range of vehicles on our roadways, from lightweight cars (approx. 820kg [1800 lb.]) to full size pickup trucks (approx. 2000 kg [4400 lb.]) as specified by the FHWA. A product can be certified for multiple Test Levels. The Energite® III/Fitch® Universal Module Systems is certified to the Test Level(s) as shown below:

Test Level 3: 100 km/h [62 mph]

**These FHWA directed tests are not intended to represent the performance of systems when impacted by every vehicle type or every impact condition existing on the roadway. This system is tested only to the test matrix criteria of NCHRP 350 as approved by FHWA.**

Valtir does not represent nor warrant that the results of these controlled tests show that vehicle impacts with the products in other conditions would necessarily avoid injury to person(s) or property. Impacts that exceed the specifications of the system may not result in acceptable crash performance as outlined in NCHRP Report 350, relative to structural adequacy, occupant risk, and vehicle trajectory. Valtir expressly disclaims any warrant or liability for injury or damage to persons or property resulting from any impact, collision, or harmful contact with products, other vehicles, or nearby hazards or objects by any vehicle, object or person, whether or not the products were assembled by or under the direction of Valtir or by third parties.

## **Important Introductory Notes**

Proper deployment and maintenance of the Energite® III/Fitch® Universal Module Systems is critical to achieve performance under appropriate state and federal guidelines. Take the time to thoroughly review this Manual, including the Limitations and Warnings section, before performing the necessary work. Do not attempt to assemble any Energite® III/Fitch® Universal Module Systems without the proper plans and assembly Manual from the manufacturer.

If you require additional information, or have questions about the Energite® III/Fitch® Universal Module Systems, please contact Valtir Customer Service Department. See Customer Service Contacts on Page 3 of this Manual.

## **System Overview**

The Energite® III/Fitch® Universal Module systems are gating, non-redirective, and easy-to-assemble crash cushions consisting of a number of sand-filled modules that are assembled in a specific geometric array in front of a hazard.

Each module of the Energite® III consists of a one-piece barrel, a lid, and in some cases a cone insert. The cone insert is used to adjust the sand height or center-of-mass and the overall weight of the barrel. The barrel's weight requirement is determined by its place within the array.

Each module of the Fitch® Universal Module consists of one set of walls, one core, one lid and four zip strips. These components will make any weight module 90k 180, 320, 640, 960 kg (200, 400, 700, 1400 and 2,100 lb.) required.

The Energite® III/Fitch® Universal Module Systems modules are available in 90, 180, 320, 640 and 960 kg (200, 400, 700, 1400 and 2,100 lb.) sizes. Refer to Figures 1A/B and 2A/B.



## Recommended Tools

Before leaving for your site, be sure you have the following tools required for Energite® III/Fitch® Universal Module Systems Assembly.

- Sand truck
- Paint (to mark barrel locations on pavement)
- Shovel
- Broom
- Hammer and Nails (if required)
- Drill and Expansion Bolts (if required)

**Note:** The above list of tools is a general recommendation. Depending on specific site conditions and the complexity of the assembly specified by the appropriate highway authority, additional or fewer tools may be required. The decisions as to what tools are needed to perform the job are entirely within the discretion of the specifying highway authority and the authority's selected contractor performing the assembly of the system at the authority's specified assembly site.

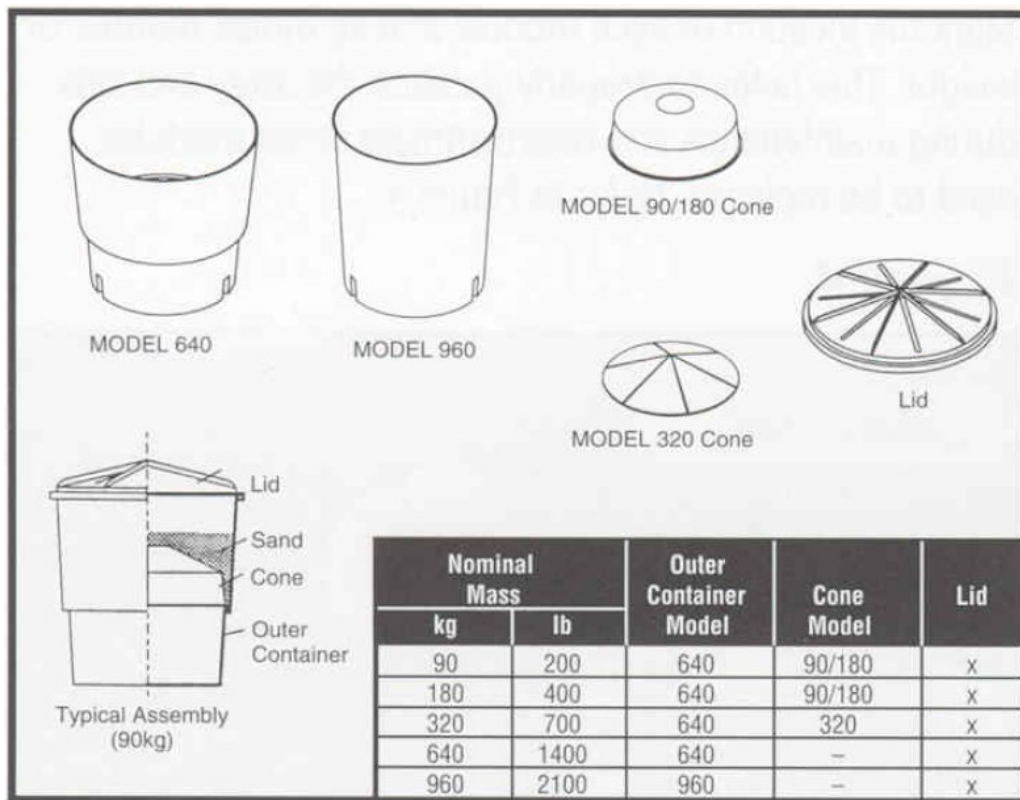

**Figure 1A Energite® III**

## **Site Preparation/Foundation**

The Energite® III/Fitch® Universal Module Systems can be deployed on concrete or asphalt surfaces at sites with a maximum grade (lateral and longitudinal) of 5%. If the grade is greater than 5%, the site will require grading before assembly can begin.

All curbs and raised islands should be removed. Where this is not possible, a maximum of 100 mm (4") high is recommended. The site must also be clear of debris and snow.

## **Inspect Shipment**

Before assembling the Energite® III/Fitch® Universal Module Systems, check the inventory of parts against the shipping list supplied with the unit. Make sure that all parts have been received. In addition, verify that you have the array specifications provided by the manufacturer and responsible agency.

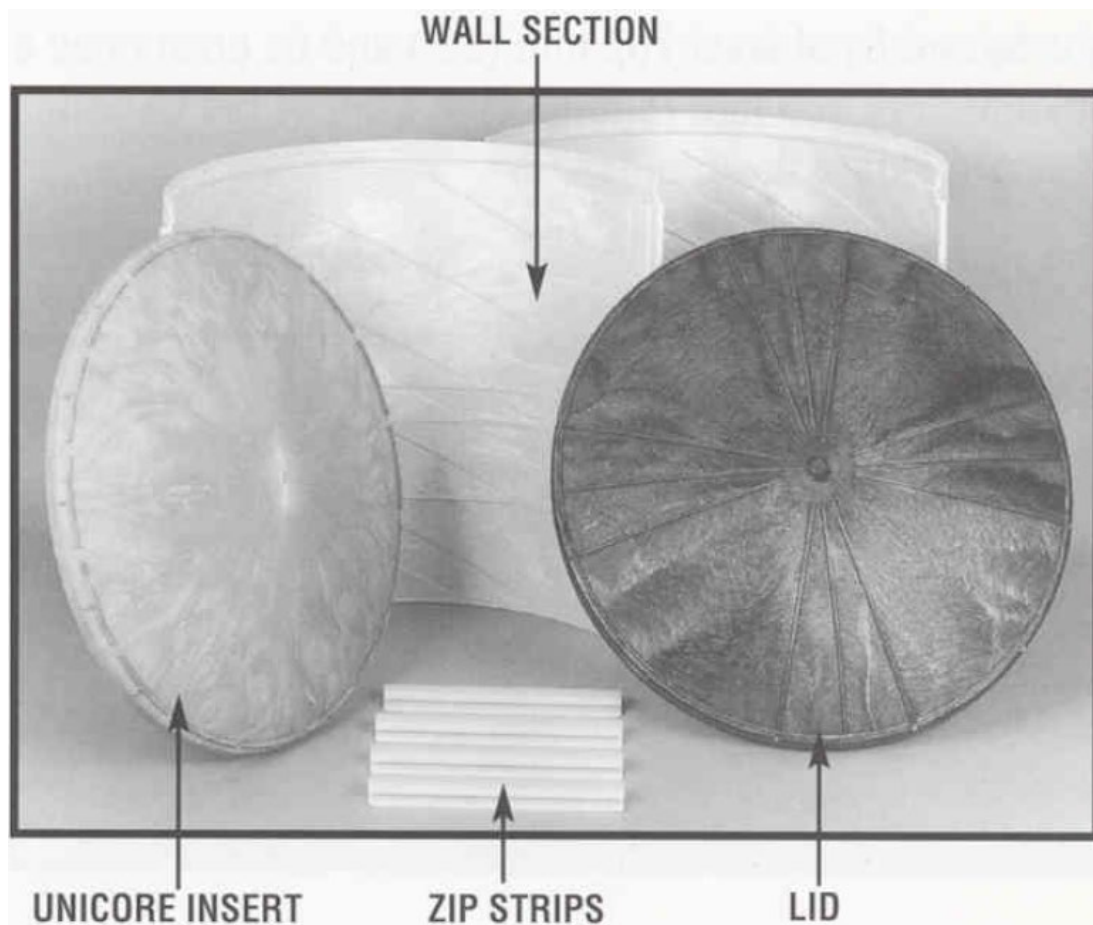

**Figure 1B-Fitch® Universal Module System**

## **Assembly**



**Caution:** The Energite® III/Fitch® Universal Module Systems array should be designed and specified by a qualified engineer assigned this task by the appropriate highway authority. Improper placement could result in excessive “G” levels for errant vehicles and possible injuries to occupants.

The Energite® III/Fitch® Universal Module Systems should be assembled in order of the steps to follow.

### **1) Place traffic control devices**

Place traffic control devices to protect your crew and motorists.

### **2) Review array specifications**

Carefully review the array specification provided by a qualified engineer.

### **3) Take measurements**

Take measurements to properly position the first row of barrels (closest to the hazard) according to the specifications. These barrels must be laterally offset from the hazard by at least 762 mm (30”) and be positioned a minimum of 305 mm (12”) in front of the hazard (See Figure 2).

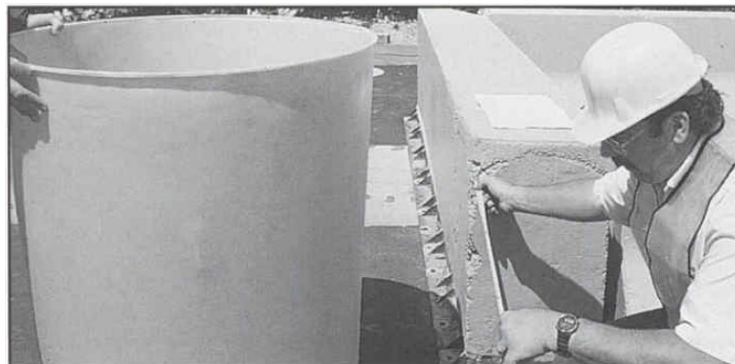

**Figure 2**

### **4) Position the barrels**

Position the barrels with approximately 152 mm (6”) of space between them (measured at the top of the barrel) according to the array specifications (See Figure 3).

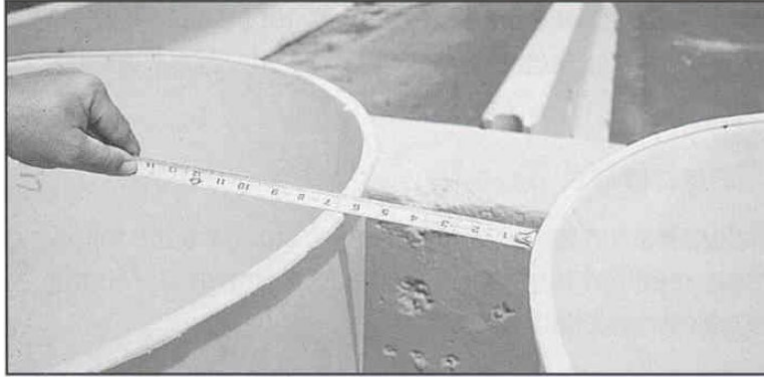

**Figure 3**

**5) Trace its circumference**

As each barrel is placed in its proper location, trace its circumference onto the pavement, then remove the barrel to allow for the next step.

**6) Marking the location**

Mark the location of each module and its model number or weight. This helps to properly position the array and aids during maintenance and refurbishment when modules need to be replaced (See Figure 4).



**Figure 4**

**7) Moving barrels into position**

After the location of each module is marked on the pavement, place the barrels back into their proper positions. Move the barrels into position one row at a time while they are empty (See Figure 5).

When Energite® III/Fitch® Universal Module Systems modules are placed on slopes or vibrating surfaces, the modules may be held into place on:

- Concrete by two expansion bolts through holes, 180 degrees apart in the bottom.
- Asphalt by four galvanized nails driven through the bottom, 90 degrees apart, 75 mm (3") from the outside wall of the barrel with full penetration.

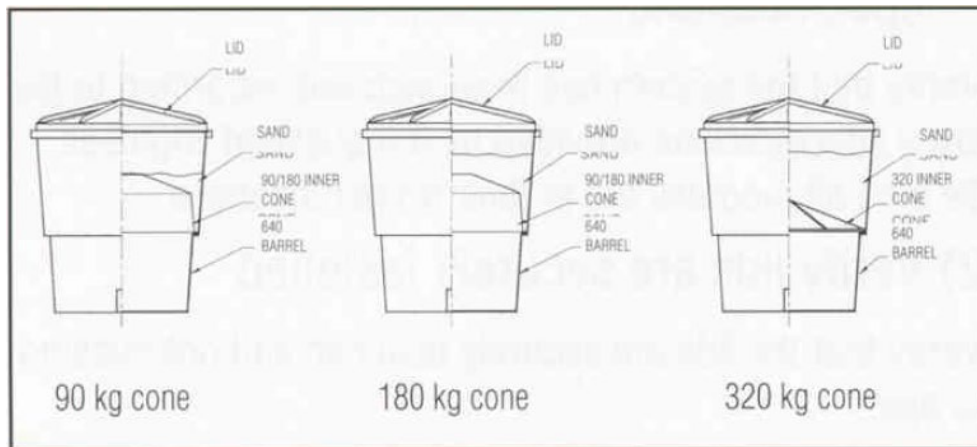

**Figure 5**

**8) Placement of inner cones - Energite® III**

Place the appropriate inner cones on the ledge inside the barrel for the 90, 180 and 320 kg (200, 400 and 700 lb.) modules. (The 640 and 960 kg modules do not require a cone insert.) Refer to Page 9 (Figure 1A) of this Manual for a drawing and description of the module components.

**Note:** The same Energite® III cone is used for the 90 and 180 kg (200 and 400 lb.) modules. Be sure that all cones are in the proper position (See Figure 6A).



**Figure 6A Energite® III System**

**9) Placement of inner cones – Fitch®**

For a 200 lb. module place the Unicore on the top shelf (17"); fill to the scribe mark (FILL TO HERE FOR 200#) resulting in a 7" sand depth and a 12" void at top.

For a 400 lb. module place the Unicore on the top shelf (17"); fill to the scribe mark (FILL TO HERE FOR 400#) resulting in a 10.5" sand depth and a 8.5" void at top.

For a 700 lb. module place the Unicore on the second shelf from the top (14"); fill to the scribe mark (FILL TO HERE FOR 700#) resulting in a 16" sand depth and a 12" void at top.

For a 1400 lb. module place the Unicore on the third shelf from the top (8.5"); fill to the scribe mark (FILL TO HERE FOR 1400#) resulting in a 27.5" sand depth and no void at top.

For a 2100 lb. module place the Unicore on the bottom shelf (.5"); fill to the scribe mark (FILL TO TOP FOR 1400# + 2100#) resulting in a 35.5" sand depth and no void at top.

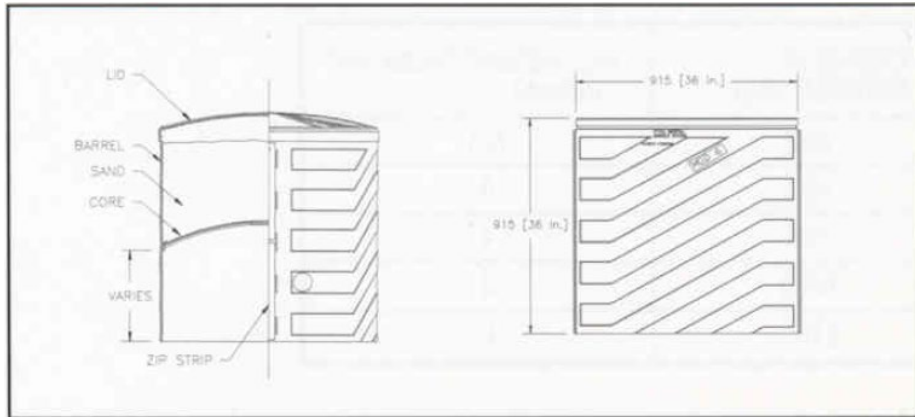

**Figure 6B Fitch® Universal Module System**

**Note:** Orient the zip strips towards oncoming traffic. A grazing impact now hits only side of the module. This leaves the zip strips and other side of the module intact, reducing cost of replacement parts and making for less clean-up (See Figure 6B).

#### 10) Filling the barrels

Once the first row of modules (last row in array) is in place, they can be filled with the proper level of sand using a sand-filled cement truck (See Figure 7).



**Figure 7**

The sand must conform to ASTM C-33 (washed concrete sand or equal). The level is indicated on the decal located on the inside of the module. Fill heights marked on the decal are based on a sand density of 1600 kg/m<sup>3</sup> (100 pcf). For other densities, see the "Fill Height" charts in Figures 8 and 9.



**Caution:** During the filling process, it is very important that the modules are filled with the proper level of sand. Refer to Figures 8 and 9, which show the correct Fill Heights for the sand.

### Proper Sand Levels

FITCH® UNIVERSAL MODULE (lbs)	FILL HEIGHT FROM TOP (inches)
200	12
400	8.5
700	6
1400	Top
2100	Top

Figure 8-Fitch® Universal Module  
Proper Sand Levels

ENERGITE® MODULE (lbs)	FILL HEIGHT FROM TOP (inches)
200	8.5
400	5
700	4
1400	3
2100	0

Figure 9 - Energite® III



**Caution:** If the modules are located where freezing temperatures might occur, mix the sand with 5% rock salt by weight to prevent the sand from freezing. Be sure the salt is evenly dispersed in the sand.

#### 11) Lid Placement

The lids can be snapped firmly into place. After the first row is finished, the next row of modules can be positioned, filled, and the lids snapped on until all the rows are completed. Be sure the lids are snapped firmly into place to prevent water and debris from entering the barrels, which can adversely affect the system's performance.

### Alternate Assembly Option

- 1) The Energite® Barrels feature a convenient one-piece design with a solid bottom. This allows the modules to be fully assembled and filled at a remote site and then transported to the deployment site. The fully-assembled modules can be lifted on and off the truck using a crane and lifting device.
- 2) Barrels may be placed on 100 mm (4") maximum height pallets for temporary assembly.

## **Checking the Assembled System**

After assembling an array, it is important to check the system before leaving the site:

### **1) Verify assembly according to array specifications**

Verify that the system has been assembled according to the array specifications provided by the qualified engineer. Be sure all modules are in their proper locations.

### **2) Verify lids are securely fastened**

Verify that the lids are securely fastened and not missing or ajar.

### **3) Clean up**

Clean up any debris around the system that could cause ramping.

## **Maintenance Checklist**

It is important to inspect the systems often because an impact can occur at any time. Two types of inspections should be performed regularly:

- Visual Drive-by Inspection
- Walk-up Inspection

## **Visual Drive-By Inspection Checklist**

Drive-by inspections are recommended as needed based upon volume of traffic and frequency of impacts. If any of the following conditions are noticed, a walk-up inspection is warranted. Required corrections must be made as soon as possible.

### **1) Check the modules**

Check the modules for any visible damages.

### **2) Check the lids**

Check the lids to see if any are missing or ajar.

### **3) Check for debris**

Check for debris around the modules that could cause ramping.

### **4) Check for objects**

Check for objects on top of the modules

### **5) Note the location**

Note the location and condition of the Energite® III/Fitch® Universal Module systems array and date of the visual drive-by inspection in your maintenance log.



## Walk-Up Inspections Checklist

Physical inspections are recommended as needed based upon volume of traffic and impact history. If system repairs are necessary, refer to the Refurbishment Instructions in the Manual. Complete the following steps during the walk-up inspection:

**1) Lids in place**

Be sure all lids are firmly in place.

**2) Lids not inverted**

Be sure lids are not inverted inwards.

**3) Modules**

Be sure modules are not tilted or leaning.

**4) Damaged modules**

Be sure modules are not cracked and outer shells are not damaged

**5) Proper location**

Be sure modules have not been moved from their proper locations.

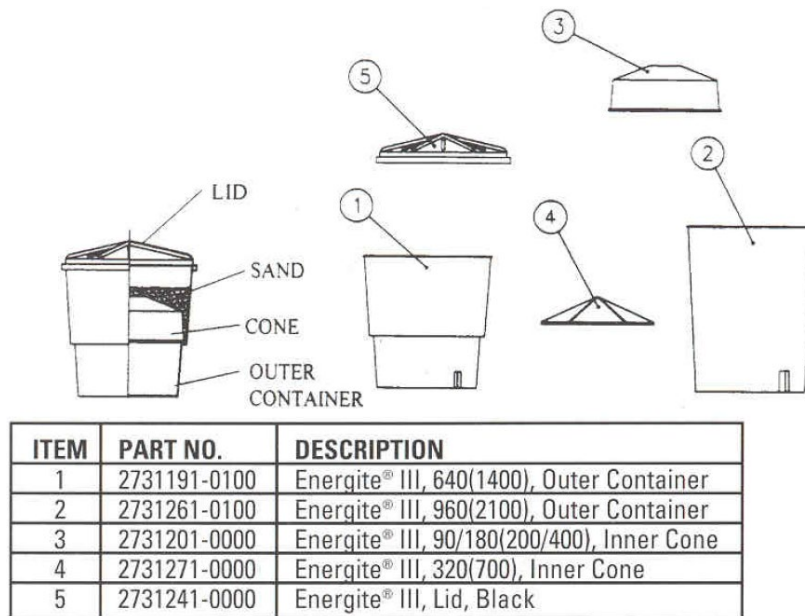

**Figure 10-Energite® III**

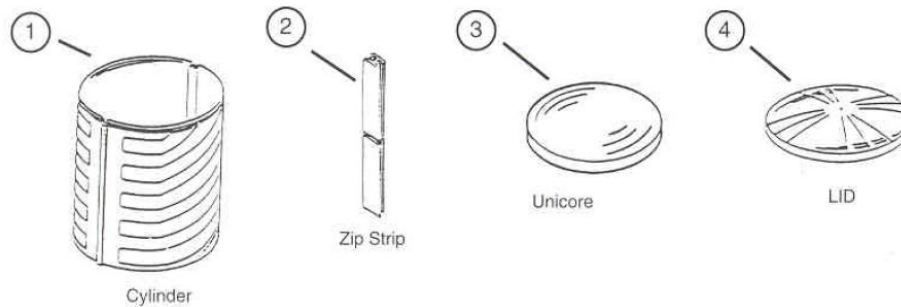

ITEM	PART NO.	DESCRIPTION
1	2200	Fitch®, Wall Half
2	2510	Fitch®, Zip Strip w/ Hole
	2520	Fitch®, Zip Strip w/o Hole
3	2400	Fitch®, Unicore
4	2300	Fitch®, Lid

**Figure 11-Fitch® Universal Module Systems**

## **Refurbishment Procedures**

Because much of the Energite® III/Fitch® Universal Module Systems are destroyed on impact, refurbishment usually involves replacing the damaged barrels, which is sometimes the entire system. When refurbishing the system, complete the following steps. Additional information is available in the Energite® III/Fitch® Universal Module Systems Assembly Manual if required.

**Note:** The Energite® III System has been enhanced. The Model 4 cone has been eliminated, reducing the number of parts. What was previously the Model 2 cone is now referred to as the Model 90/180 cone and is used for both the 90 and 180 kg modules. When upgrading or repairing arrays, it is recommended to replace cones to meet the current standards.

### **1) Setting up traffic control**

Set up traffic control to protect your crew as designated by the appropriate highway authority in their plans and specifications for this particular job.

### **2) Removal of debris**

Using brooms, shovels and other equipment, remove the sand and debris from the site. This sand may be used later for filling the replacement barrels, but it must first be cleared of all debris.

### **3) Positioning of barrels**

Place the first row (closest to the hazard) of new barrels in their proper positions using the markings on the roadway surface, which indicate the location of the new barrels.



**Caution:** At the time of assembly, a number indicating the location for each model type should have been painted on the roadway surface. Assemble the array following the markings at the site.

#### 4) Other surfaces

When replacement modules are placed on slopes or vibrating surfaces, the modules may be held into place on:

- Concrete by two bolts through holes, 180 degrees apart in the bottom.
- Asphalt by four galvanized nails driven through the bottom, 90 degrees apart, 75 mm (3") from the outside wall of the barrel with full penetration.

#### 5) Placement of inner cones

Place the appropriate inner cones on the ledge inside the replacement barrels for the 90, 180 and 320 kg (200, 400 and 700 lb.) modules. (The 640 and 960 kg modules do not require a cone insert.)

**Note:** The same cone is used for the 90 and 180 kg (200 and 400 lb.) modules. Be sure that all cones are in the proper position and the module is filled to the proper sand level (See Page 13).

#### 6) Filling of sand

Once the first row of modules is in place, they can be filled with the proper level of sand. (An efficient method of quickly filling the Energite® III/Fitch® Universal Module Systems modules is to use a sand filled cement mixer.)

The sand must conform to ASTM C-33 (washed concrete sand or equal). The level is indicated on the decal located on the inside of the module. Fill heights marked on the decal are based on a sand density of 1600 kg/m<sup>3</sup> (100 pcf).



**Caution:** If the modules are located where freezing temperatures might occur, mix the sand with 5% rock salt by weight to prevent the sand from freezing. The rock salt should be evenly dispersed throughout the sand.

#### 7) Snap the lids

Snap the lids firmly into place and begin working on the next row of modules using the same procedure until all rows are completed.

#### 8) Clean up

Clean up any final debris at the site.

### Alternate Refurbishment Option

The Energite® III barrels feature a convenient, one-piece design with a solid bottom. This allows the replacement modules to be fully assembled and filled at a remote site and then transported to the damaged site. The fully-assembled modules can be lifted on and off the truck using a crane and lifting device.

The Fitch® Universal Module design allows quick refurbishment on nuisance hits and may require one-half of the modules to be replaced.



**Notes:**

**Notes:**