

# Vulcan<sup>®</sup> Gate

## GATE

### PRODUCT DESCRIPTION ASSEMBLY MANUAL



# Vulcan<sup>®</sup> Gate

The Vulcan<sup>®</sup> Gate has been tested pursuant to National Cooperative Highway Research Program (“NCHRP”) Report 350 specifications. The Vulcan<sup>®</sup> Gate has been deemed eligible for federal-aid reimbursement on the National Highway System by the Federal Highway Administration (“FHWA”).

## Product Description Assembly Manual



15601 Dallas Parkway  
Suite 525  
Addison, Texas 75001



**Warning:** The local highway authority, distributors, owners, contractors, lessors, and lessees are responsible for the assembly, maintenance, and repair of the Vulcan<sup>®</sup> Gate. Failure to fulfill these **RESPONSIBILITIES** with respect to the assembly, maintenance, and repair of the Vulcan<sup>®</sup> Gate could result in serious injury or death.



**Important:** These instructions are for standard assembly specified by the appropriate highway authority. In the event the specified system assembly, maintenance, or repair would result in a deviation from these assembly instructions, contact the appropriate highway authority engineer.

**This manual must be available to the worker overseeing and/or assembling the product at all times. For additional copies, contact Valtir at (888) 323-6374 or visit [Valtir.com](http://Valtir.com).**

The instructions contained in this manual supersede all previous information and manuals. All information, illustrations, and specifications in this manual are based on the latest Vulcan<sup>®</sup> Gate information available to Valtir at the time of printing. We reserve the right to make changes at any time. Please contact Valtir to confirm that you are referring to the most current instructions.

## **Table of Contents**

Customer Service Contacts .....	3
Important Introductory Notes .....	3
Safety Symbols .....	4
Safety Rules for Assembly .....	4
Limitations and Warnings .....	4
Know Your Vulcan® Gate .....	6
Opening Options .....	8
Length of Need .....	11
Vulcan® Gate Tested Lateral Deflection .....	11
Curves .....	12
Slopes .....	12
Hills .....	13
Ditch .....	13
Curbs .....	13
Trenches .....	13
Deployment .....	14
Preparation .....	14
Deployment .....	14
Recommended Tools .....	16
Vulcan® Gate – Typical Layout .....	17
Anchoring (Transitions/CMB) .....	20
Valtir Approved Adhesive Anchoring System .....	21
Vertical Assemblies .....	21
Anchor Assembly Cautions .....	22
Horizontal Assemblies .....	23
Operation .....	24
Maintenance and Repair .....	25
Final Inspection Checklist .....	26

## Customer Service Contacts

Valtir is committed to the highest level of customer service. Feedback regarding the Vulcan® Gate, its assembly procedures, supporting documentation, and performance is always welcome. Additional information can be obtained from the contact information below:

### Valtir

Telephone	(888) 323-6374 (USA) +1 214 589-8140 (International)
E-mail	<a href="http://Valtir.com/Contact">Valtir.com/Contact</a>
Website	<a href="http://Valtir.com">Valtir.com</a>

## Important Introductory Notes

Proper assembly of the Vulcan® Gate is critical to achieve performance that has been evaluated and accepted by the FHWA per NCHRP Report 350. These instructions should be read in their entirety and understood before assembling the Vulcan® Gate. These instructions are to be used only in conjunction with the assembly of the Vulcan® Gate and are for standard assemblies only as specified by the applicable highway authority. If you need additional information, or have questions about the Vulcan® Gate, please contact the highway authority that has planned and specified this assembly and, if needed, contact Valtir's Customer Service Department. This product must be assembled in the location specified by the appropriate highway authority. If there are deviations, alterations, or departures from the assembly protocol specified in this manual, the device may not perform as it was tested and accepted.

This system, like other Valtir systems, has been crash tested pursuant to NCHRP Report 350 mandated criteria.



**Important: DO NOT** use any component part that has not been specifically crash tested and/or approved for this system during assembly, repair, or maintenance of this system. The use of component parts not specifically crash tested or approved for use is prohibited.

This product has been specified for use by the appropriate highway authority and has been provided to that user who has unique knowledge of how this system is to be assembled. No person should be permitted to assist in the assembly, maintenance, or repair of this system that does not possess the unique knowledge described herein. These instructions are intended for an individual who is qualified to both read and accurately interpret them as written. These instructions are intended only for an individual experienced and skilled in the assembly of highway products that are specified and selected by the highway authority.

A manufacturer's drawing package will be supplied by Valtir upon request. Each system will be supplied with a specific drawing package unique to that system. Such drawings take precedence over information in this manual and shall be studied thoroughly by a qualified individual who is skilled in interpreting them before the start of any product assembly.

## Safety Symbols

This section describes the safety symbols that appear in this Vulcan® Gate manual. Read the manual for complete safety, assembly, operating, maintenance, repair, and service information.

<u>Symbol</u>	<u>Meaning</u>
---------------	----------------



**Safety Alert Symbol:** Indicates Danger, Warning, Caution, or Important. Failure to read and follow the Danger, Warning, Caution, or Important indicators could result in serious injury or death to workers and/or bystanders.



**Important:** Read safety instructions thoroughly and follow the assembly directions and suggested safe practices before assembling, maintaining, or repairing the Vulcan® Gate. It is the responsibility of the installer to follow the instructions contained in this manual. Failure to follow this warning could result in increased risk of serious injury or death in the event of a vehicle impact with a system.



**Important:** Please keep up-to-date instructions for later use and reference by anyone involved in the assembly of the product.

## Safety Rules for Assembly

### \* Important Safety Instructions \*

This manual must be kept in a location where it is readily available to persons who assemble, maintain, or repair the Vulcan® Gate. Additional copies of this manual are available from Valtir by calling (888) 323-6374 or visiting [Valtir.com/Contact](http://Valtir.com/Contact). Please contact Valtir if you have any questions concerning the information in this manual or about the Vulcan® Gate.

It is the responsibility of the installer to use appropriate safety precautions when operating power equipment, mixing chemicals, and when moving heavy equipment or any Vulcan® Gate components. Gloves, protective clothing, eye protection, safety-toe shoes, and back protection should be used.



**Warning:** Safety measures incorporating appropriate traffic control devices specified by the highway authority must be used to protect all personnel while at the assembly, maintenance, or repair site.



**Warning:** It is the responsibility of the installer to follow these warnings. Failure to comply with these warnings could result in increased risk of serious injury or death in the event of a vehicle impact with a system that has not been accepted by the FHWA.



**Warning:** Use only Valtir parts on the Vulcan® Gate for assembly, maintenance, or repair. **The assembly or comingling of unauthorized parts is strictly PROHIBITED.** The Vulcan® Gate and its component parts have been accepted for state use by the FHWA. However, a comingled system has not been accepted within the applicable criteria.

## Limitations and Warnings



Valtir, in compliance with the National Cooperative Research Highway Program 350 (NCHRP Report 350) "Recommended Procedures for the Safety Performance of Highway Safety Features," contracts with FHWA approved testing facilities to perform crash tests, evaluation of tests, and submittal of results to the FHWA for review.

The Vulcan® Gate has been approved by FHWA as meeting the requirements and guidelines of NCHRP Report 350. These tests typically evaluate product performance defined by Report 350 involving a range of vehicles on roadways, from lightweight cars (approx. 820 kg [1800 lb.]) to full size pickup trucks (approx. 2000 kg [4400 lb.]). The Vulcan® Gate is certified to the Test Level(s) as shown below:

**Test Level 2: 820 kg [1800 lb], 70 km/h [43 mph], 20 degrees**

**Test Level 3: 2000 kg [4400 lb], 100 km/h [62 mph], 25 degrees**

**Test Level 4: 8000 kg [17,600 lb], 80 km/h [50 mph], 15 degrees**

**These FHWA directed tests are not intended to represent the performance of systems when impacted by every vehicle type or every impact condition existing on the roadway. This system is tested only to the test matrix criteria of NCHRP Report 350 as approved by FHWA.**

Valtir expressly disclaims any warranty or liability for injury or damage to persons or property resulting from any impact, collision or harmful contact with products, other vehicles, or nearby hazards or objects by any vehicle, object or person, whether or not the products were assembled in consultation with Valtir or by third parties.

The Vulcan® Gate is intended to be assembled, delineated, and maintained within specific state and federal guidelines. It is important for the highway authority specifying the use of a highway product to select the most appropriate product configuration for its site specifications. The customer should be careful to properly select, assemble, and maintain the product. Site lay out, vehicle population type; speed, traffic direction, and visibility are important elements that require evaluation in the selection of a highway product. For example, curbs could cause an untested effect on an impacting vehicle.

After an impact occurs, the debris from the impact should be removed from the area immediately and the specified highway product should be evaluated and restored to its original specified condition or replaced as the highway authority determines as soon as possible.



**Warning:** Do not assemble, maintain, or repair the Vulcan® Gate until you have read this manual thoroughly and completely understand it. Ensure that all Danger, Warning, Caution, and Important statements within the manual are completely followed. Please call Valtir at (888) 323-6374 if you do not understand these instructions.



**Warning:** Ensure that all of the Vulcan® Gate Danger, Warning, Caution, and Important statements are completely followed. Failure to follow this warning could result in serious injury or death in the event of a collision.

## Know Your Vulcan® Gate

The Vulcan® Gate can be specified for use in many applications.

Some examples are:

- Median or Roadside Placement
- Emergency Cross-over Access
- General road maintenance performed by road authorities, contractors, local municipalities etc.
- Road Construction
- Lane Closures
- Toll Plazas
- Road Resurfacing
- Excavation or Culvert Protection
- Detours or Diversions
- Bridge Repairs
- Temporary or Permanent Placement

In order to design the most appropriate Vulcan® Gate for a given site, this manual helps to answer the following questions:

- Is the Vulcan® Gate appropriate for my site?
- What is the application? What warrants the use of the Vulcan® Gate?
- How long or short can the Vulcan® Gate be?
- How much clear zone is available, and how much is required for the correct functioning of the system?
- Are there curves, slopes, or curbs present which may not suit the Vulcan® Gate?

The purpose of this manual is to supply some basic application information about the Vulcan® Gate and to detail its performance when tested to NCHRP Report 350.

If you would like further assistance, please contact Valtir (p. 3).



**Warning:** Do NOT modify the Vulcan® Gate in any way.



**Warning:** It is the responsibility of the installer to ensure that the Vulcan® Gate and delineation used meet all federal, state, specifying agency, and local specifications.



**Warning:** It is the responsibility of the state specifying agency and the installer to ensure that your assembly meets all appropriate Manual on Uniform Traffic Control Devices (MUTCD) and local standards.

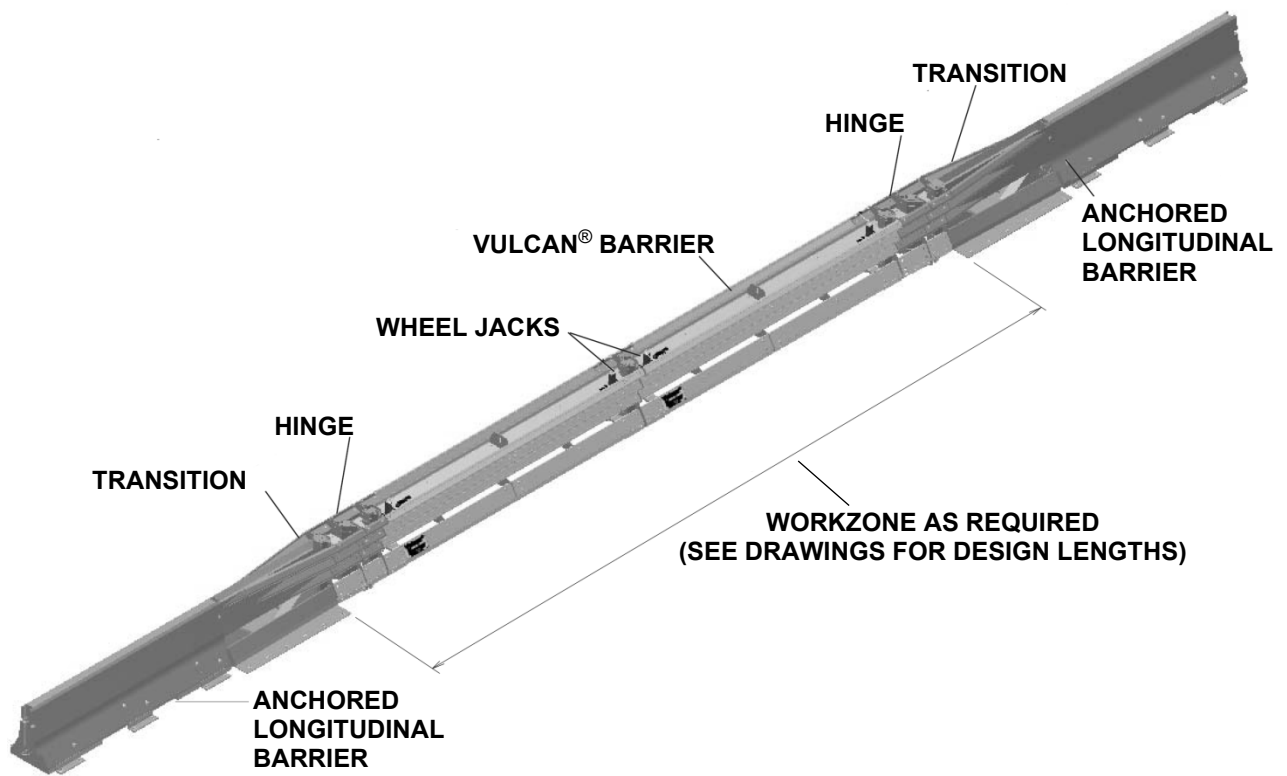

**Figure 1 – System Overview**



# Opening Options



Figure 2a



Figure 2b

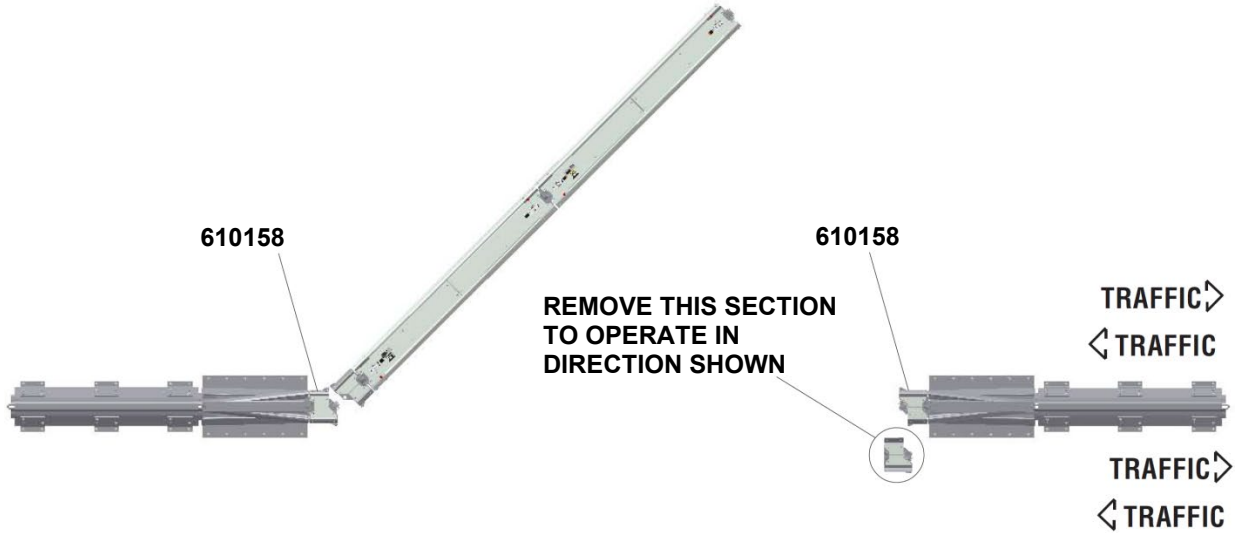

Figure 2c

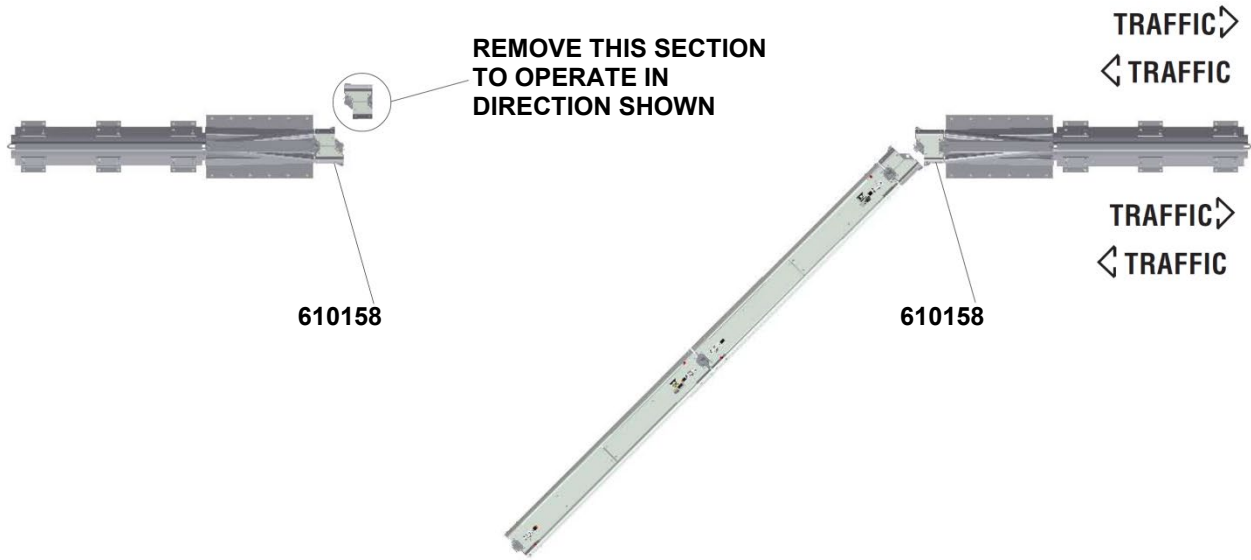

Figure 2d

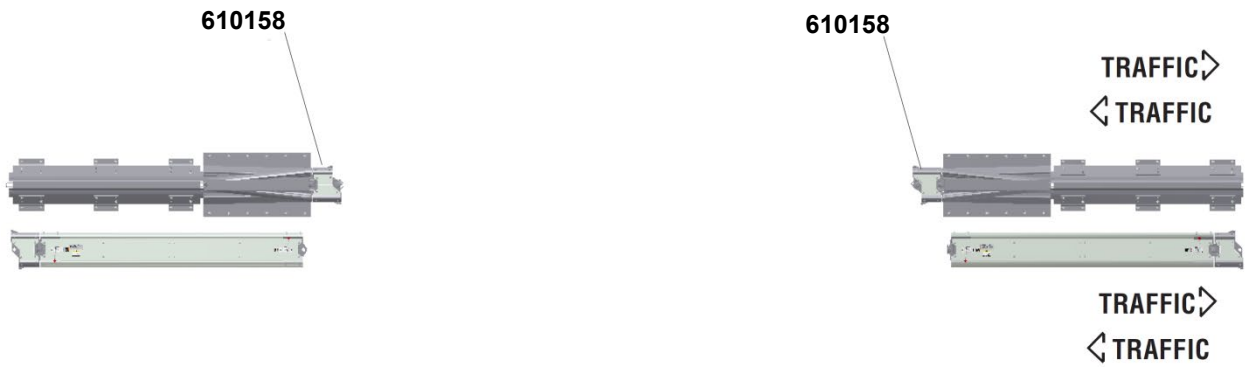

Figure 2e – Open Along Barrier

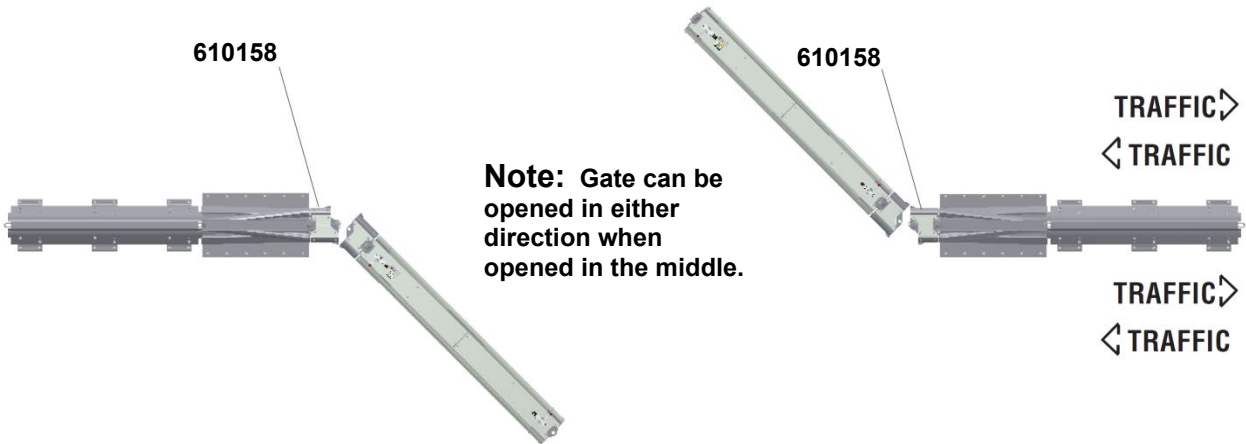
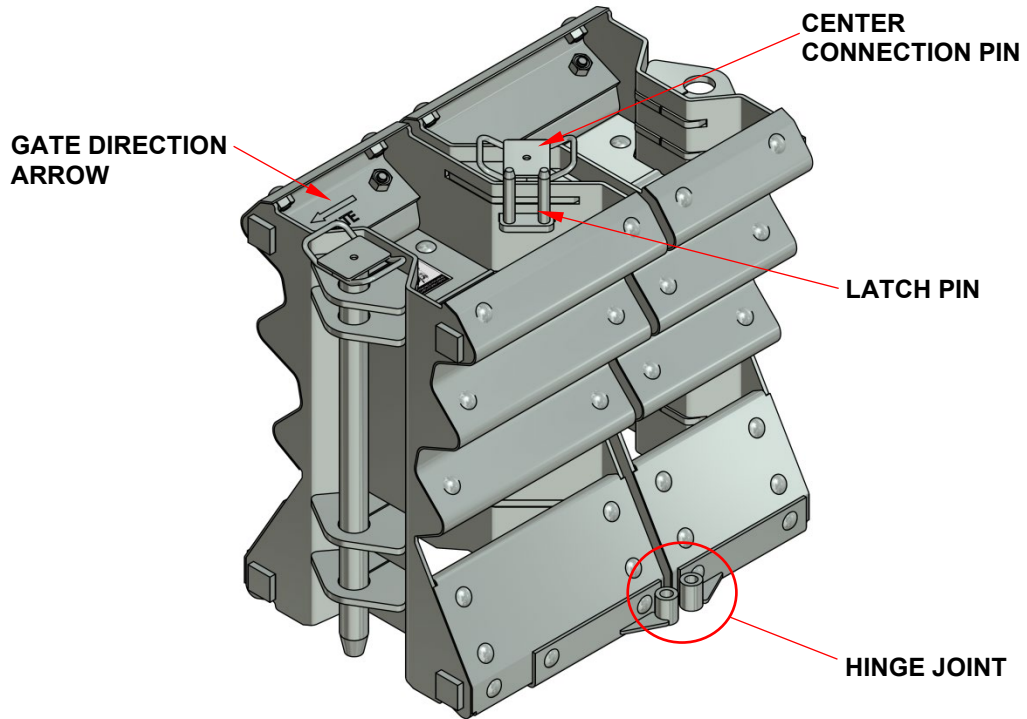
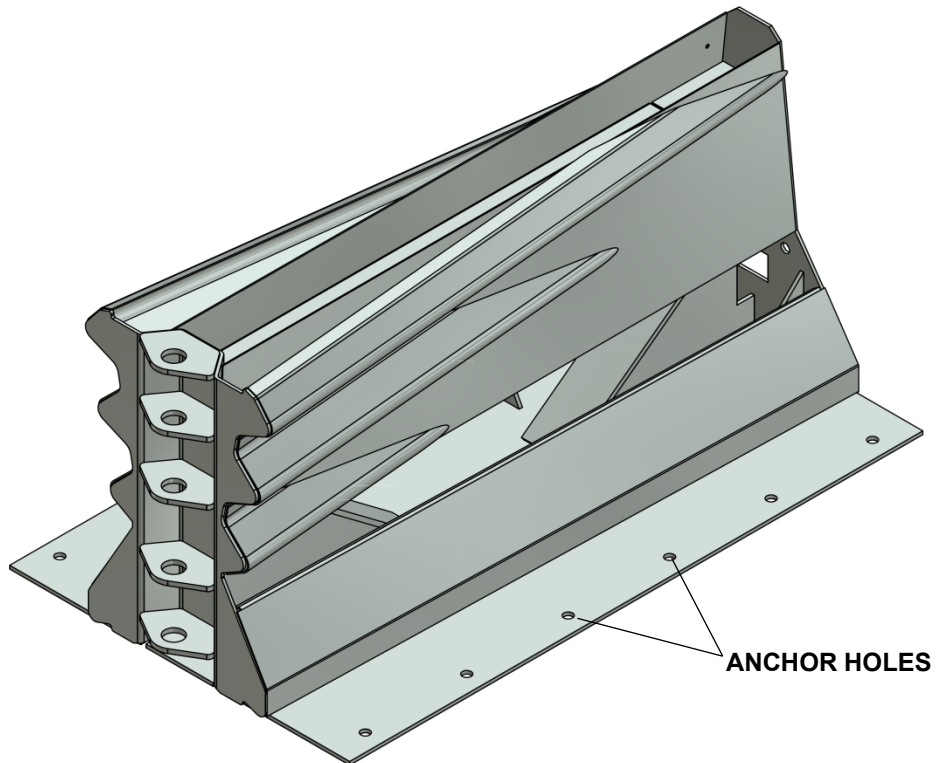

Figure 2f – Open Middle Opposite



**Figure 3 – Vulcan® Gate Hinge (PN 610158)**



**Figure 4 - Vulcan® Transition (PN 616199)**

## Length of Need

Length of need (L.O.N.) is defined as the total length of a longitudinal barrier needed to shield an area of concern as determined by the highway authority specifying the use of this product. It is also described as that part of a longitudinal barrier or terminal designed to contain and redirect an errant vehicle. The L.O.N. varies depending on what use the Vulcan® Gate is being specified for by the highway authority.

The Vulcan® Gate is deployed as a barrier gate which can be placed in the middle of the longitudinal barrier or Vulcan® Barrier when all criteria of design drawings are met. The Vulcan® Gate is deployed longitudinally and incorporates various sections of Vulcan® Barrier that require specific opening sizes.

## Vulcan® Gate Tested Lateral Deflection

The Vulcan® Gate, since it is made up of the Vulcan® Barrier, has been considered to pass all NCHRP Report 350 test criteria where maximum dynamic deflection was experienced. The TL-3 deflection results on the Vulcan® Gate for the 2000P @ 25 degrees was 3'-7" [1.1 m]. This test was directly positioned at the hinge and transition of the unit to determine vehicle interaction.

### 2000 kg Pick-up Truck Test – Vulcan® Gate

Deflection is 3'-7" [1.1 m] for the 25 degree impact at 100 kph [62 mph] (TL-3)

- Deflection calculations are based on the TL-3 Beginning Length Of Need (B.L.O.N.).

The TL-3 results for the 2000P @ 25 degrees are taken directly from the NCHRP Report 350 test results and represent the maximum dynamic deflection experienced.

Dynamic deflection represents the maximum amount of lateral movement of the system. Testing has confirmed that the permanent static deflection is approximately 10% less than the dynamic deflection.

## Curves

The ends of each section are constructed with knuckles that interlock with those of other segments. The end knuckles are vertically aligned to accept a steel connecting pin. The pin securely joins the sections for maximum impact performance. The sections can swivel up to 6 degrees at the pin for easy positioning around work areas or following road contours (Figure 5).

Typical placement of Vulcan® Gate should be in straight runs with minimal curvature.



**Important:** In order to limit system deflection in critical areas such as past the work zone or other roadside features, placement of the limiting spacers between the barrier segments is required.

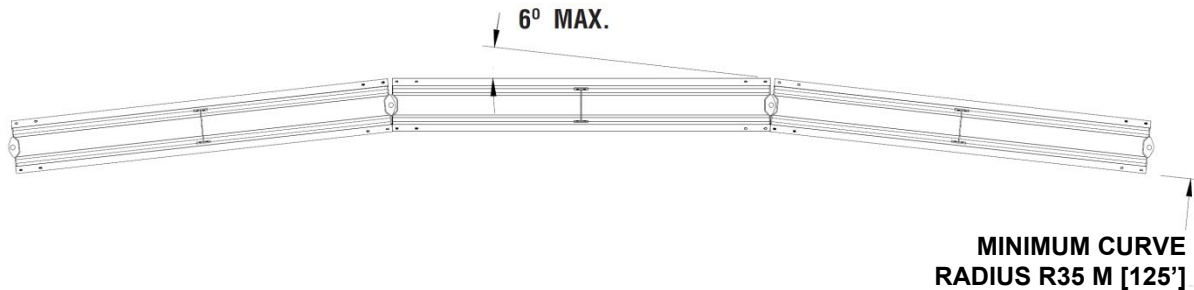

Figure 5

## Slopes

### Cross-slopes

The Vulcan® Gate may be placed on cross-slopes up to 5% [3 deg.] (Figure 6).

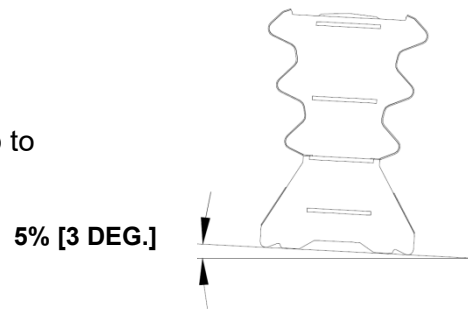

Figure 6

### Longitudinal Slopes

For Vulcan® Gates placed on slopes that exceed 5% [3 deg.] call Valtir customer support (p. 3).

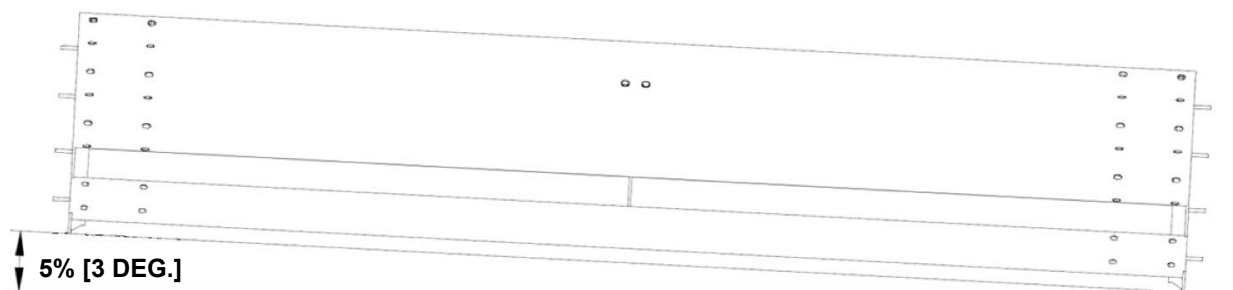

Figure 7

## Hills

The Vulcan® Gate has the ability to conform to a hill up to 20:1 (Figure 8). Please note the maximum longitudinal slope in Figure 7.

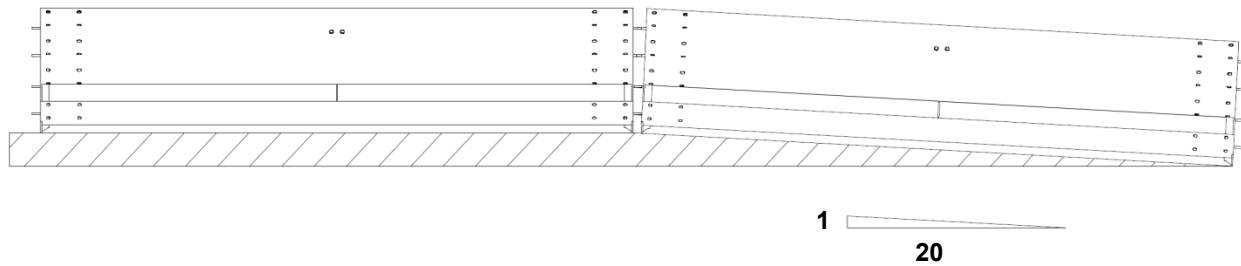

Figure 8

## Ditch

The Vulcan® Gate has the ability to conform to a ditch up to 20:1 (Figure 9). Please note the maximum longitudinal slope in Figure 7.

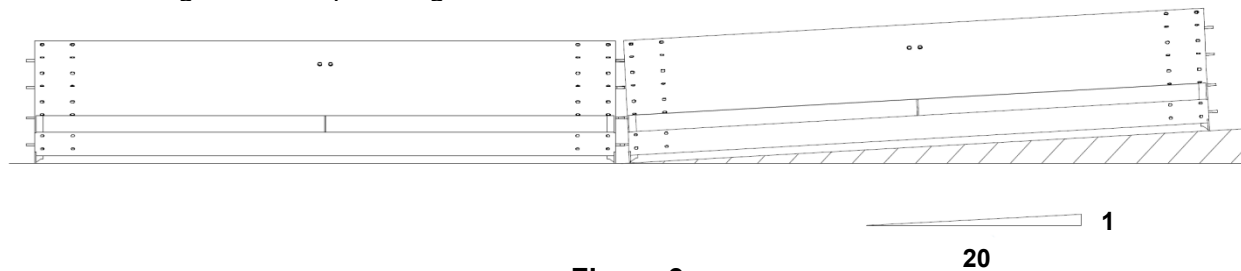

Figure 9

## Curbs

The Vulcan® Gate should **NOT** be placed directly against curbs that can prevent its lateral movement (Figure 10).

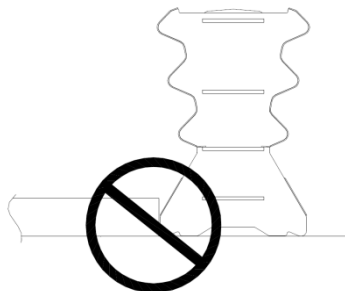

Figure 10



**Warning:** It is the responsibility of the state specifying agency and the installer to ensure that this assembly conforms with the guidance provided by the AASHTO Roadside Design Guide, including, but not limited to, those regarding placement on or adjacent to curbs.

## Trenches

The Vulcan® Gate should NOT be placed directly up to trenches or excavations where the necessary deflection of the system in the event of an impact may result in barrier failure. Reference to accepted working widths is detailed in the deflection summary (p. 11).



# Deployment

## Preparation

Begin preparing for deployment by thoroughly reviewing the specified barrier location, layout, and orientation as per the approved traffic management plan.

Determine the number of segments required for the site. The deployed length of each Vulcan® segment is 13'-6" [4 m]. A visual inspection should be carried out to confirm the suitability of all segments. Should visible damage be evident in any segments, they should be sent for inspection and refurbishment prior to use.



**Warning:** To avoid accident and injury the installer must use correct safety equipment and approved traffic management for any Vulcan® Barrier deployment.



**Important:** The Vulcan® Barrier is designed to stack up to three (3) segments in height so provision must be made to lift from a height of 7'-10 1/2" [2.4 m] plus the tray height (Stiffner).

## Deployment

1. Begin deployment at the upstream traffic end of the site and work downstream. Work from the non-traffic side of the assembly whenever possible. Unloading proceeds much faster if one person remains on the truck and two people work on the ground. If site conditions permit, a fourth person can drive the truck so that the segments can be unloaded continuously as the job progresses.
2. Align the segments according to the specified configuration and layout in the traffic control plan.



**Caution:** Refer to deflection information on page 11 when determining minimum clearance between barrier and roadside feature.



**Caution:** The existence of any cross-slopes in excess of 5% (3 deg.) or curbs may create an untested effect on the impacting vehicle.

3. Insert two (2) transitions (one at the beginning of the system and one at the end) and attach to existing longitudinal barrier. Anchor adjacent barrier only as specified per manufacturer's instructions.



**Important:** Attach the hinge sections to transitions with connecting pins. Ensure top tab of pins are on swinging side of gate and that gate direction arrows are pointing to the median opening (Figure 11).

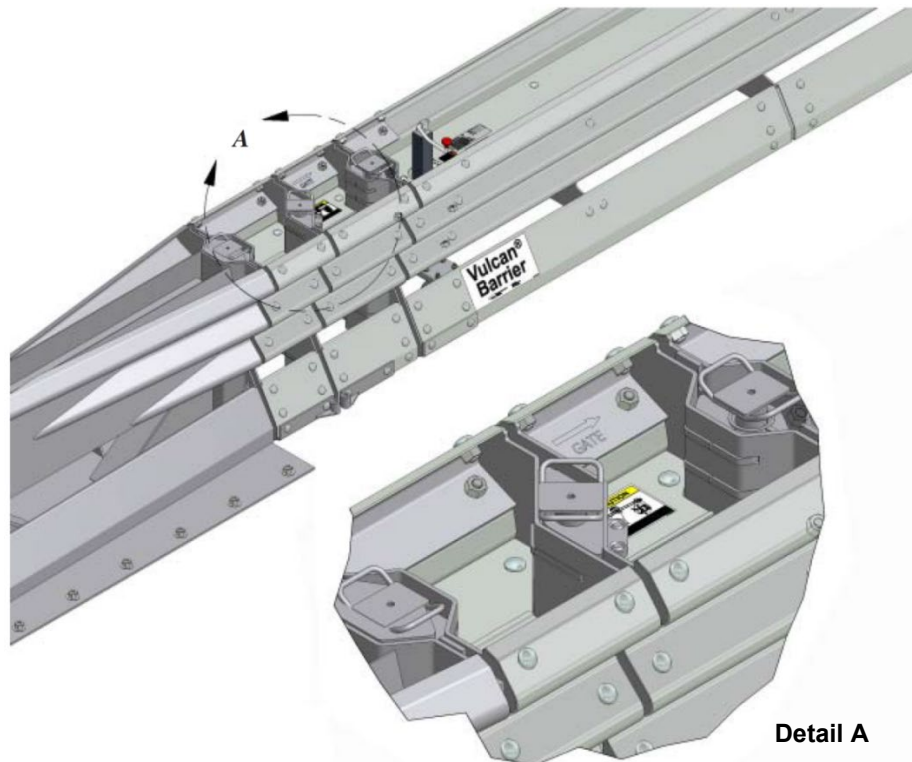

**Figure 11**

4. Bring the segments together and insert a connecting pin through the overlapping end knuckles at each joint. Push the pin in until it is flush with the top of segments.  
Spacers (PN 614552) are used to minimize joint rotation. Valtir recommends inserting spacers for optimum performance and minimum lateral deflection.  
No Spacer (PN 614552) is needed when connecting the Vulcan Hinge to the Vulcan Gate transition.
5. After the system is in place and pinned together, make sure the jacks on each Vulcan® Barrier section are in the raised position and all barriers are completely settled on the roadway.
6. Check to make sure all connection pins remove easily. Lubricate as needed (WD40) and reposition Vulcan® Barrier and Hinge if necessary.



**Important:** Ensure that the deflection limiting spacers are inserted between all segments where the minimum deflection of the system is desired at Beginning of Length Of Need (B.L.O.N.).

## Recommended Tools

- Vulcan® Gate manual
  - Transport truck
  - Sledge hammer
  - Pry bar
  - Generator (power for optional accessories)
  - A truck mounted crane or forklift suited to a minimum 400 kg (900 lb.) lift and appropriate slinging gear
  - 7/8" Concrete drill bits (\*Double Fluted)
  - Grinder, hacksaw, or torch (optional)
  - Drill motor
  - Drill bits: 1/16" through 7/8"
- \* Valtir recommends using double fluted drill bits to achieve optimum tensile strength when mounting with an approved adhesive (p. 21).
- Rotary hammer drill
  - Standard hammer
  - Heavy duty impact wrench
  - 1/2" drive sockets: 9/16", 11/16", 3/4", 15/16", 1 1/8", 1 1/4"
  - Ratchet and attachments for the above sockets
  - Breaker bar: 1/2" x 24"
  - Torque wrench: 300 ft-lb
  - Crescent wrench: 12"
  - Impact wrench: 1/2" Drive
  - Lubrication (WD40)
  - Manufacturer's print package
  - Applicable location, layout, orientation, and construction plans
  - Traffic control equipment (as required)

**Note:** The above list of tools is a general recommendation. Depending on specific site conditions and the complexity of the assembly specified by the appropriate highway authority, additional or fewer tools may be required. Decisions as to what tools are required to perform the job are entirely the responsibility of the specifying highway authority and the authority's selected contractor performing the assembly of the system at the authority's specified site.

MODEL #	MEDIAN OPENING	GATE OPENING	617660B (QTY)	610158B (QTY)	616029B (QTY)
616950B	13.3m [43'-8"]	6.9m [23'-0"]	2	2	2
616951B	17.46m [57'-3 1/2"]	12.79m [41'-11 1/2"]	3	2	2
616952B	21.61m [70'-10 1/2"]	17.28m [56'-8"]	4	2	2
616953B	25.75m [84'-6"]	21.42m [70'-3 1/2"]	5	2	2
616954B	29.90m [98'-1"]	25.57m [83'-10 1/2"]	6	2	2

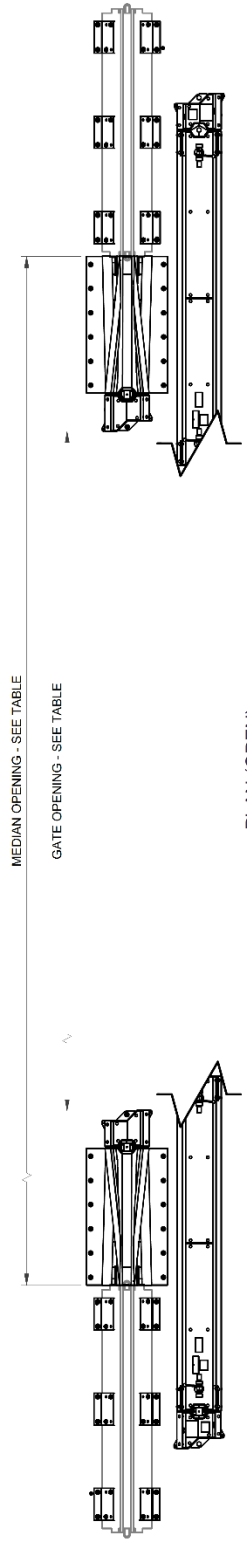

PLAN (OPEN)

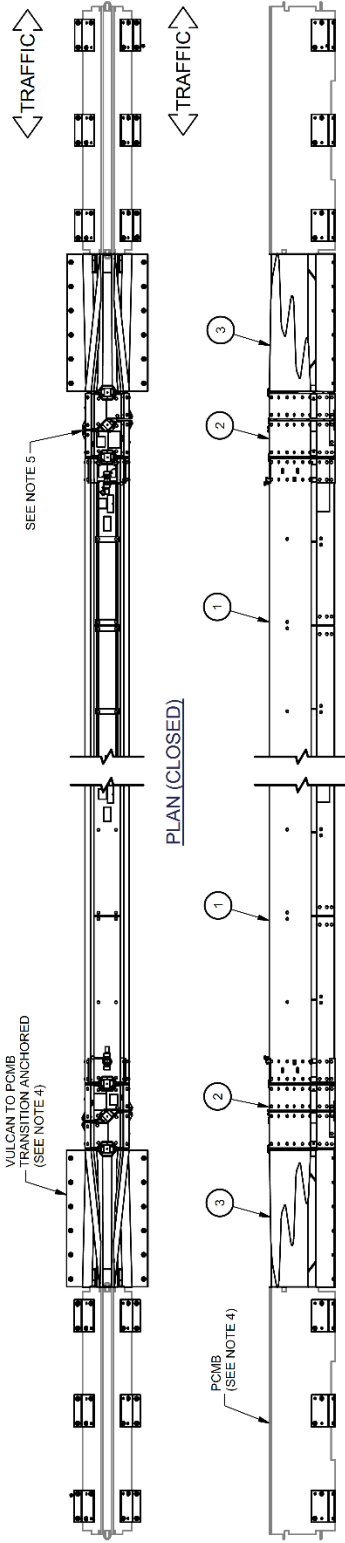

PLAN (CLOSED)

ELEVATION (CLOSED)

- NOTES:
- SEE VULCAN BARRIER PRODUCT MANUAL FOR A DESCRIPTION OF ITS IMPACT PERFORMANCE CHARACTERISTICS AND DESIGN LIMITATIONS BEFORE PLACING A SYSTEM AT A GIVEN SITE. INFORMATION AND ADDITIONAL COPIES OF ABOVE MANUAL ARE AVAILABLE BY CALLING CUSTOMER SERVICE DEPARTMENT AT (312) 467-6750.
  - CUSTOMER BARRIERS NEED TO BE PINNED AND SPACERS USED.
  - JACK WHEELS SHALL BE RETRACTED WHEN BARRIER IS NOT BEING MOVED.
  - TRANSITIONS AND ADJACENT PCMB SHALL BE ANCHORED. SEE REFERENCE DRAWING 616029B.
  - REFER TO VULCAN MANUAL FOR OPERATIONAL PROCEDURES AND OTHER OPTIONS.

KEY	DESCRIPTION	SERIAL NO.	SALES ORDER	EH PROJECT	NO. OF UNITS
1	VULCAN w/JACKS				
2	HINGE				
3	TRANSITION				

REV	BY	DATE	DESCRIPTION
1	D. Hayes Jr.	8/12/2009	
2	A. Van Brocklin	8/10/2009	
3	J. Espinoza	12/2/2009	
4	A. Van Brocklin	12/2/2009	

617660B		610158B		616029	
VULCAN w/JACK		HINGE ASSY VULCAN		VULCAN-PCMB TRANSITION	

SCALE	NTS	DATE	VGCVR	REV	1	OF	1	FIG	C
-------	-----	------	-------	-----	---	----	---	-----	---

## Vulcan® Gate – Typical Layout

BIDIRECTIONAL

VULCAN™ GATE

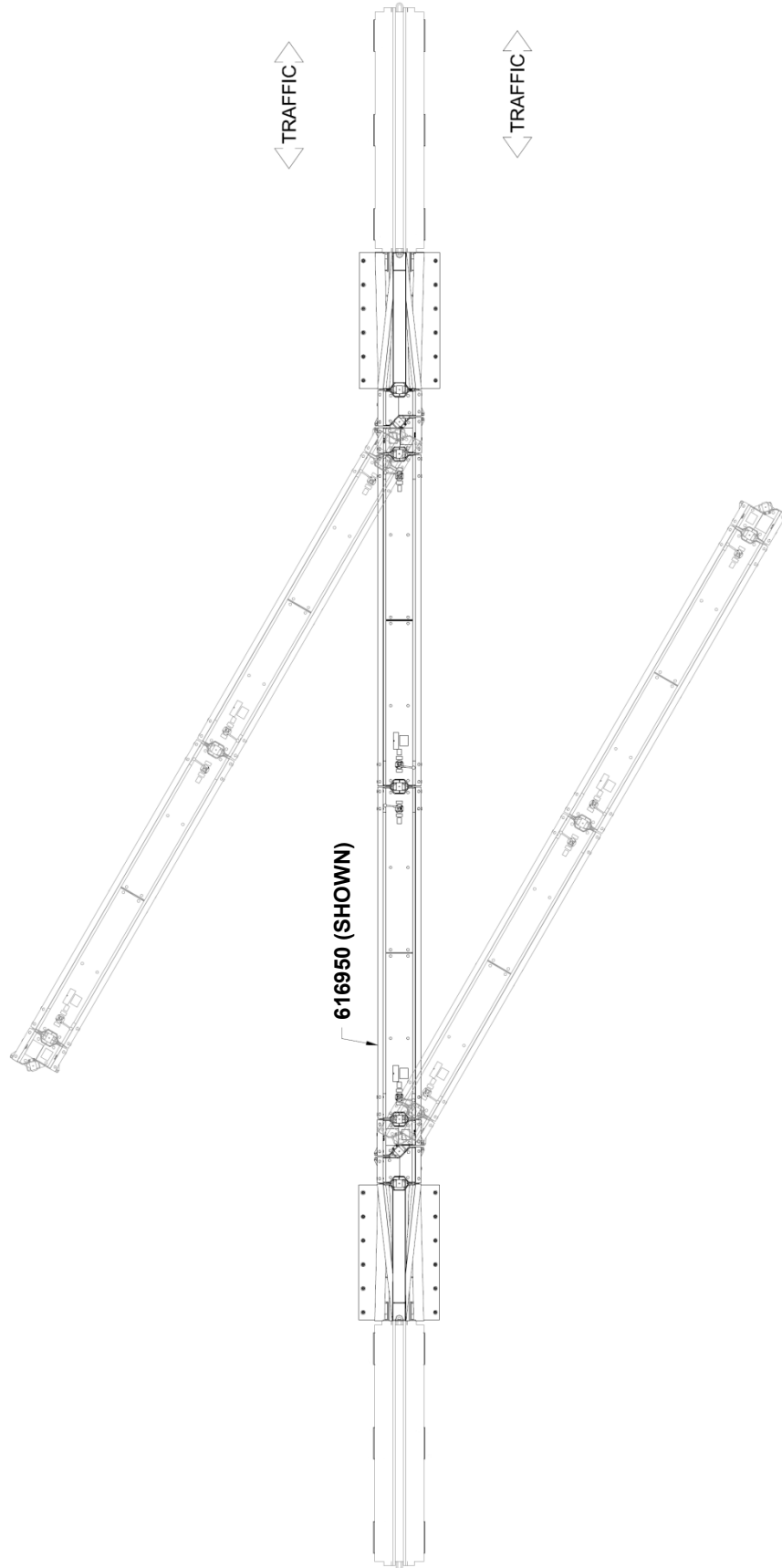

Figure 12 – Long Section Swings Either Way

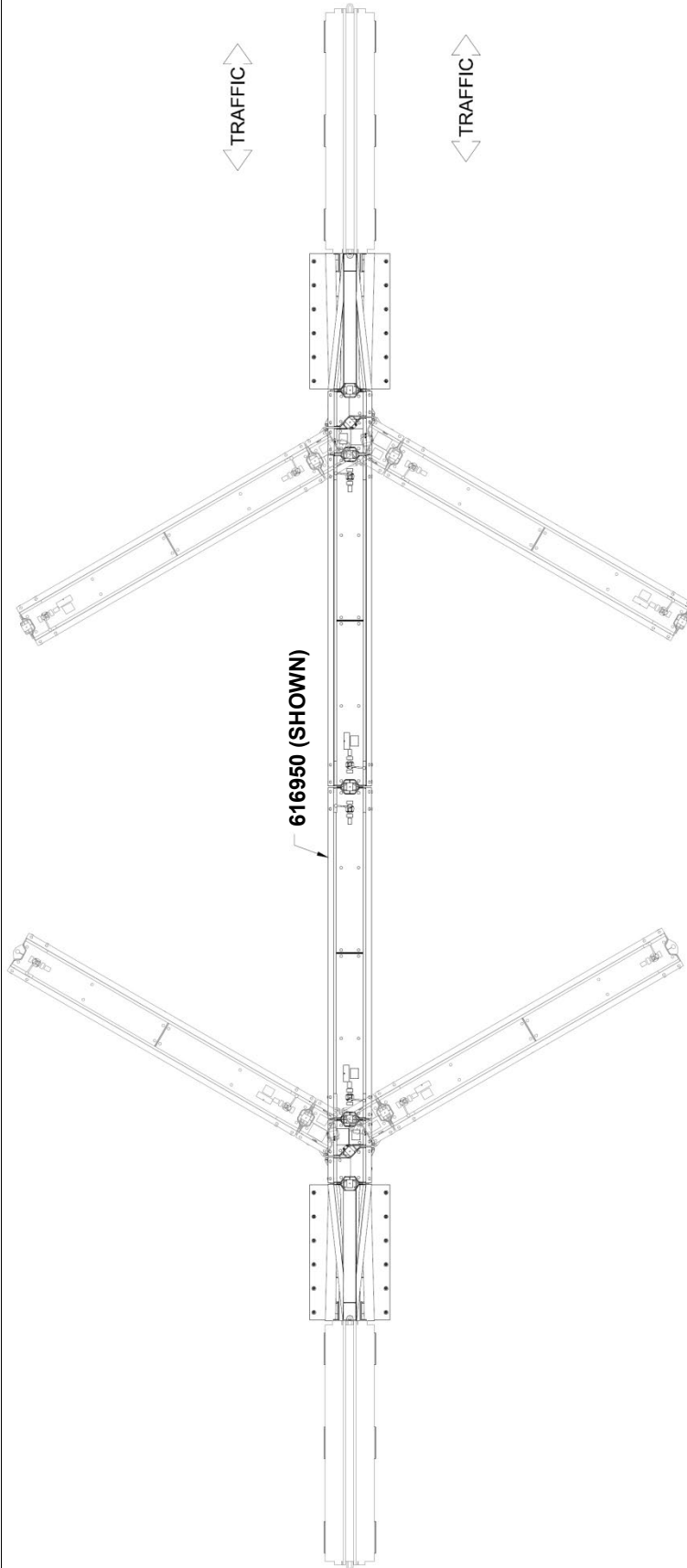

Figure 13 – Short Section(s) Swing Open as Illustrated



## Anchoring (Transitions/CMB)

The Vulcan® Gate has two (2) anchored ends that attach to the hinge/connector that allows the Gate to operate and open to the desired position. The anchored ends are crucial to the system, in that they keep the system from moving if it is impacted.

These anchored end components are called transitions. They typically transition from Vulcan® Gate to various longitudinal barriers.

The transition is not connected to the adjacent barrier, only to the roadway itself. The transition and the first section of longitudinal barrier must be securely anchored using an approved adhesive anchoring system (p. 21).



**Important: Contact Valtir Customer Support for anchor options (p. 3).**

### Vulcan® Gate Anchoring Alternatives

The Valtir Approved Adhesive Anchoring System is recommended for use with the Vulcan® Gate (p. 21).

Occasionally, the approved adhesive system may not fulfill all requirements of a particular deployment, i.e. removal of the anchors after a temporary placement, certain bridge deck applications or embedment in varying road surfaces. Valtir has qualified alternative anchoring systems that may better fit the requirement.



**Important: Contact Valtir Customer Support for alternative anchoring recommendations if the approved anchoring system does not meet your specific site needs (p. 3).**

# Valtir Approved Adhesive Anchoring System

A Valtir approved adhesive anchoring system is required to securely anchor longitudinal barriers. Each approved adhesive kit contains adhesive, studs, nuts and washers. Both vertical and horizontal assemblies are possible using an approved adhesive anchoring system.

## Vertical Assemblies

**Note:** Read all Valtir approved adhesive instructions before starting.

### 1) Prepare the Concrete Foundation



**Warning:** Do not allow anchoring adhesive to contact skin or eyes. See safety data sheet supplied with adhesive kit for first-aid procedures. Use only in well-ventilated area. Do not use near open flame.



**Warning:** Proper PPE including gloves and eye protection are required during application.

The anchor bolts (studs) that anchor the Vulcan® Gate transition section to the concrete foundation must be those shipped in the kit or of high strength steel (830 MPa [120,000 psi] minimum tensile strength or equal). These studs must be set in minimum 28 MPa [4000 psi] concrete. Allow the concrete to cure a minimum of seven days before applying anchoring adhesive.

### 2) Drill Boreholes



**Caution:** It is the responsibility of the installer to consult OSHA silica respiratory standard 29 CFR 1910.134 for debris removal from borehole(s) and use Valtir approved adhesive to achieve optimum tensile strength. Do not use diamond drill bits for drilling boreholes.

Use the transition as a drilling template. Use a rotary hammer drill to drill the boreholes 22 mm [7/8"] diameter to the recommended depth. See the approved adhesive instructions provided with adhesive kit. Check to ensure each borehole is drilled to the proper depth and aligned with the part to be anchored per chart below.

Anchoring Information					
Stud Size:	Orientation	Bit Size	Minimum Depth	Torque	Medium
3/4"x 6 1/2"	Horizontal	7/8" [22 mm]	5 1/4" [133 mm]	Manufacturer Spec	Concrete
3/4"x 7"	Vertical	7/8" [22 mm]	5 3/4" [145 mm]	Manufacturer Spec	Concrete
3/4"x 18"	Vertical	7/8" [22 mm]	16 3/4" [425 mm]	10 ft-lb [15 N-m]	Asphalt



**Important:** When mounting on asphalt, initial torque shall be as shown above. Due to the properties of asphalt, anchors may loosen over time. For this reason Valtir recommends anchoring to asphalt only at temporary locations. It is recommended to re-torque anchors in asphalt every six (6) months to the proper initial torque specified.

### 3) Clean the Boreholes

Blow the concrete dust from the borehole using oil-free compressed air. Thoroughly brush it with a 7/8" diameter steel bristle tube brush and then blow it out again. If the borehole is wet, completely flush it with water while brushing and then blow it clean to remove all water using oil-free compressed air.

**Note:** Use of Valtir approved vacuum drilling equipment is authorized to replace the blowing and brushing requirement in Step 3.

### 4) Apply Approved Adhesive

Fill the borehole 100% full.



**Caution:** Fill borehole 100% full so it is even with the pavement surface per manufacturer's instructions.

### 5) Add Nuts to Anchor Studs

Place a flat washer onto the stud then thread a nut on until the end of the stud is flush with the NUT (Figure 14).

### 6) Insert Studs in Boreholes and Wait for Adhesive to Cure

Push the stud down through the part to be anchored and into the borehole. Give the stud several twists in the approved adhesive to wet the threads.



**Caution:** Do not disturb or load the stud until the approved adhesive material has hardened (see instructions supplied with the approved adhesive kit).

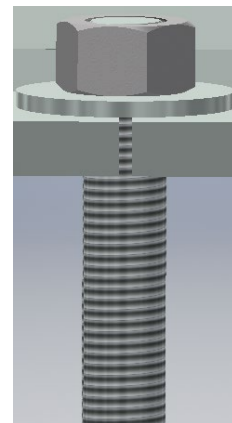

### 7) Torque the Nuts

Once the adhesive has fully cured, torque the nut to the adhesive manufacturer's recommended values.

**Figure 14**  
**Vertical Application**  
**(Before Applied Torque)**

## Anchor Assembly Cautions

### 1) Steel Rebar

If steel rebar is encountered while drilling an anchor bolt borehole, apply one of the following solutions:

A) Use a rebar drill bit for the **rebar only** and then switch back to the concrete bit to finish drilling into the underlying concrete until the proper borehole depth is reached.



**Caution:** Do not drill through rebar without first obtaining permission to do so from the project engineer.

B) Drill a new borehole down at an angle past the rebar to the proper depth. Anchor the stud by completely filling both boreholes with an approved adhesive.

## Horizontal Assemblies

The horizontal approved adhesive kit is the same as the vertical kit.



**Caution:** Fill borehole 100% full so it is even with the surface of the hole per manufacturer's instructions.

### 1) Follow the Instructions Supplied with Your Approved Adhesive Kit

Apply approved adhesive to each anchor per instructions.

### 2) Add the Washers and Nuts

Put washer and nut on stud so the **nut is flush with end of stud**.

### 3) Insert Each Stud with Washer and Nut into Borehole

Push stud with washer and nut into borehole. Twist the stud in the approved adhesive to fully wet the threads.



**Important:** The stud should be flush with the top of the nut in both **vertical** and **horizontal** applications prior to tightening (Figure 15).

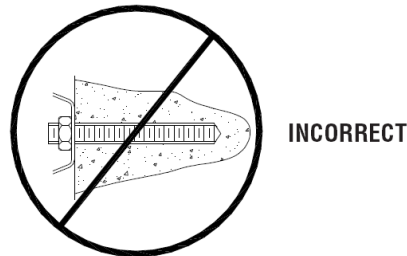
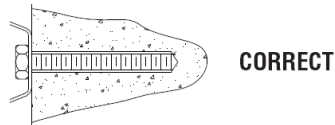

**Figure 15**  
**Horizontal Application**  
**(Before Applied Torque)**



**Warning:** Do not disturb or load the stud until the approved adhesive material has hardened (**see approved adhesive kit instructions for cure times and torque values**).

### 4) Torque the Nuts

Once the adhesive has fully cured, torque nut(s) to the approved adhesive manufacturing specification.

## Operation



**Caution:** Thoroughly check to ensure the Vulcan® Gate is clear of people, debris, or obstructions before operation.



**Important:** Do not attempt to move the Vulcan® Gate before reading the manual in its entirety. Read all warning tables on the barrier.



**Caution:** The weight of the Vulcan® Gate may cause the sections to swing into traffic. **Use extreme caution while operating the Vulcan® Gate.**

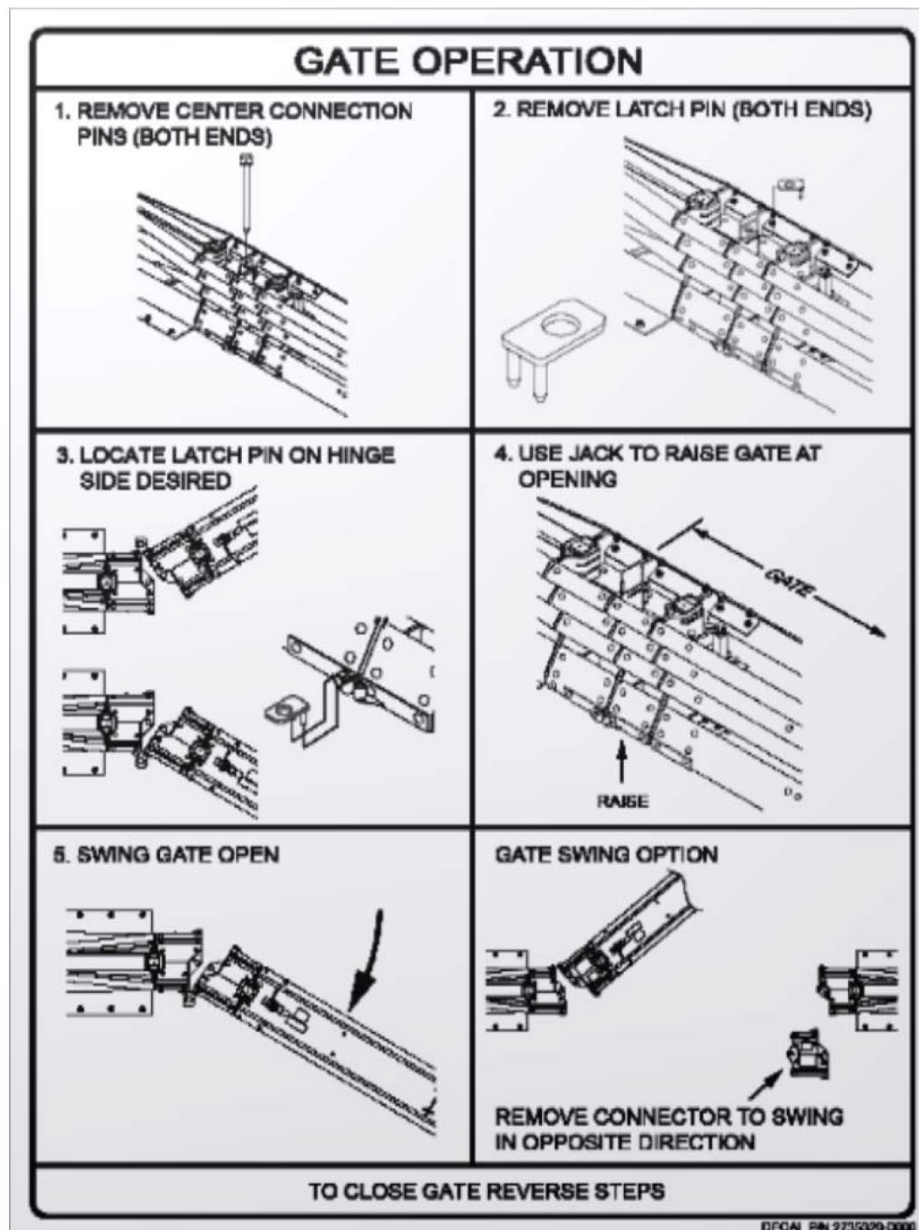

## Maintenance and Repair

Each Vulcan® Gate is made up of three main components, all of which are fully replaceable as designed to enhance a long service life.

The Vulcan® Gate is bolted together using standard guardrail hardware so any individual component can be easily removed and replaced.

Barriers which show evidence of impact will require close inspection of all struts, braces, and supports showing particular attention to weld point integrity.

The hinge and transition sections are made to unpin from the Vulcan® Gate barrier sections and the corresponding longitudinal barrier for easy replacement. As with all components after impact, inspect for any structural deformation and replace components as necessary.



**Important:** The Vulcan® Gate must be inspected and maintained monthly and semi-annually to ensure proper operation.

### **Monthly:**

- Visually inspect the Vulcan® Gate for impact or other physical damage.
- Clear gravel and other road debris from the Vulcan® Gate travel path.
- Remove any snow or ice on the Vulcan® Gate or its travel path.

### **Semi-Annually or as conditions warrant:**

- Apply light oil to the upper shaft of the jack assembly and cycle the wheels up and down twice.
- Remove each connecting pin and apply light oil or lubricant (not WD40) to the shaft of the pin.
- Operate the Vulcan® Gate assembly per the directions on page 24 of the manual.



**Important:** Valtir makes no recommendation whether use or reuse of any part of the system is appropriate or acceptable following an impact. It is the sole responsibility of the local highway authority and its engineers to make that determination. It is critical that you inspect this product after assembly is complete to make certain that the instructions provided in this manual have been strictly followed.



**Warning:** Self-repair of any components is strictly prohibited. Such configurations have not been tested, nor have they been accepted for use by the FHWA. Any damaged sections must be replaced with original modular sections supplied by the manufacturer. Failure to follow this warning could result in serious injury or death in the event of a collision.



## Final Inspection Checklist

Inspection Date: \_\_\_\_\_

Inspected By: \_\_\_\_\_

- Proper transitions are in place and are properly fitted.
- Hinge sections are in place and operational.
- All transitions and anchor straps (if applicable) have an anchor in each hole.
- Appropriate torque on all anchors.
- All connecting pins are properly inserted between each barrier.
- All hardware and fasteners are tight and has not loosened during shipment.
- System is clear of construction debris.
- Jacks are not in contact with the surface of the road when barrier is deployed.

**Copy this sheet for each inspection.**



For more complete information on Valtir products and services, visit us on the web at [www.valtir.com](http://www.valtir.com). Materials and specifications are subject to change without notice. Please contact Valtir to confirm that you are referring to the most current instructions.

**[WWW.VALTIR.COM](http://WWW.VALTIR.COM)**  
**1.888.323.6374**