



ArmorZone[®] TL-2

WATER FILLED BARRIER

By Valmont Highway

PRODUCT MANUAL



PN 120063

APRIL 2019

TABLE OF CONTENTS

1.0	ArmorZone® Introduction	3
2.0	Before Installation	3
3.0	Limitations & Warnings.....	3
4.0	System Design & Design Considerations.....	4
	Installation Layout Diagram	5
5.0	Parts Identification	6
6.0	Bill of Materials.....	6
7.0	Installation Preparation	7
8.0	Installation Instructions	8
9.0	Installation Examples.....	12
10.0	Installation Checklists.....	13
11.0	Repair Guide.....	14



APPENDIX – TECHNICAL DRAWINGS

12.0	ArmorZone® Barrier.....	15
12.1	ArmorZone® End Treatment	16

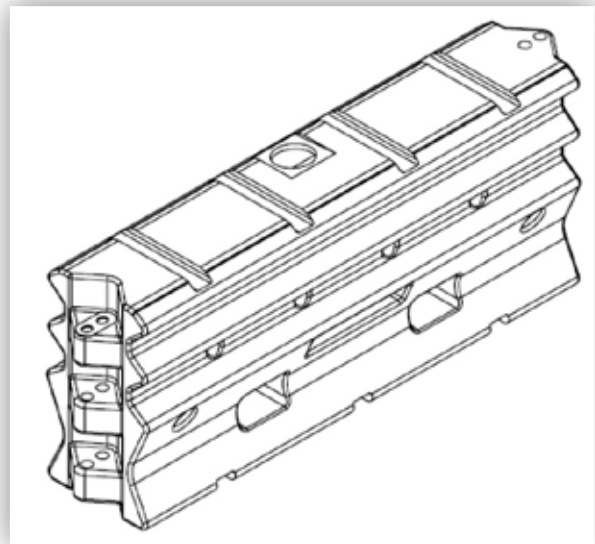

ArmorZone®, Armorflex® and Valmont Highway™ are trademarks of Valmont Industries.

1.0 INTRODUCTION

ArmorZone® is a TL-2 barrier made up of plastic units that when joined together using a steel pin and filled with water provides positive work zone barrier protection to temporary construction sites and other miscellaneous roadside activities.

The unique ArmorZone® polyethylene composition, profile design and steel pin allow the barrier to be installed straight or down to a minimum radius of 92' (28m) if required.

If required the ArmorZone® TL-2 barrier connects directly to the ArmorZone® TL-2 end treatment which negates the need to shield or flare the ends of the barrier.

ArmorZone® barrier has been designed and tested to meet the evaluation criteria of MASH Test Level 2 (TL-2) for longitudinal barriers and the end treatment.

2.0 BEFORE INSTALLATION

Placement of ArmorZone® shall be in accordance with the design as provided for the temporary work zone. Installation shall be in accordance with the installation instructions supplied for this product.

Depending on the circumstances at the site, installation including the filling of a unit (using a truck mounted water tanker) should take no more than 1 minute for each 6'-7" (2.0m) unit.

ArmorZone® is a highly engineered safety device made up of a relatively small number of parts. Before starting installation ensure that one is familiar with the make up of the system.

3.0 LIMITATIONS AND WARNINGS

ArmorZone® TL-2 barrier and end treatment have been rigorously tested and evaluated per the evaluation criteria in the MASH guidelines for longitudinal barrier guidelines for crash cushions. The impact conditions recommended are intended to address typical in-service collisions.

When properly installed and maintained ArmorZone® TL-2 barrier and end treatment allows an impacting vehicle to be stopped, contained or re-directed in a safe and predictable manner under MASH impact conditions.

Vehicle impacts that vary from the MASH impact conditions described for longitudinal barriers and crash cushions may result in significantly different results than those experienced in testing. Vehicle impact characteristics different than, or in excess of, those encountered in compliance testing (weight, speed and angle) may result in system performance that may not meet the evaluation criteria.

The ArmorZone® barrier can be installed with the ArmorZone® end treatment. If this treatment is not used the end of the barrier must be shielded or flared as per Road Controlling Authority requirements.



4.0 SYSTEM DESIGN & DESIGN CONSIDERATIONS

4.1 Slopes

A maximum slope of 10:1 is preferable.

On slopes greater than this, follow the Road Controlling Authority's guidelines.

4.2 Curbs

ArmorZone® has been designed and tested so the centre of gravity of the impacting vehicle is a constant height in relation to the barrier. For this reason, it is preferred that curbs or channels are not in front or behind the barrier as they will result in altering the height of the vehicle at impact. If there is no option but to install ArmorZone® near a curb, consult Road Controlling Authority's guidelines.



4.3 Undulating ground conditions

Site specific grading may be necessary to ensure that there are no "humps" or "hollows" that may significantly alter the impacting vehicles stability or substantially alter the barrier height in relation to the ground.

4.4 Median and Roadside Applications

ArmorZone® can be used in both 'roadside' and 'median' applications.

4.5 Minimum Length of Need

The minimum Length of Need (LoN) of ArmorZone® is 164' (50m). Ensure that when installing the barrier that it is of sufficient length. For further details consult the Road Controlling Authority's guidelines. If an ArmorZone® end treatment is connected the LoN increase to 177' (54m).

4.6 End Treatment

ArmorZone® end treatment is a free standing 'special' end unit that can be fitted to the ArmorZone® barrier in a tangent position if an end treatment is required. If an end treatment is not used it may be required to flare or shield the barrier as per Road Controlling Authority's guidelines.

4.7 Soil Conditions

ArmorZone® is installed above ground so soil conditions on site are not applicable. However it is recommended ArmorZone® systems are installed on a compacted surface.



ARMORZONE™ MASH TL2/TL1 INSTALLATION LAYOUT

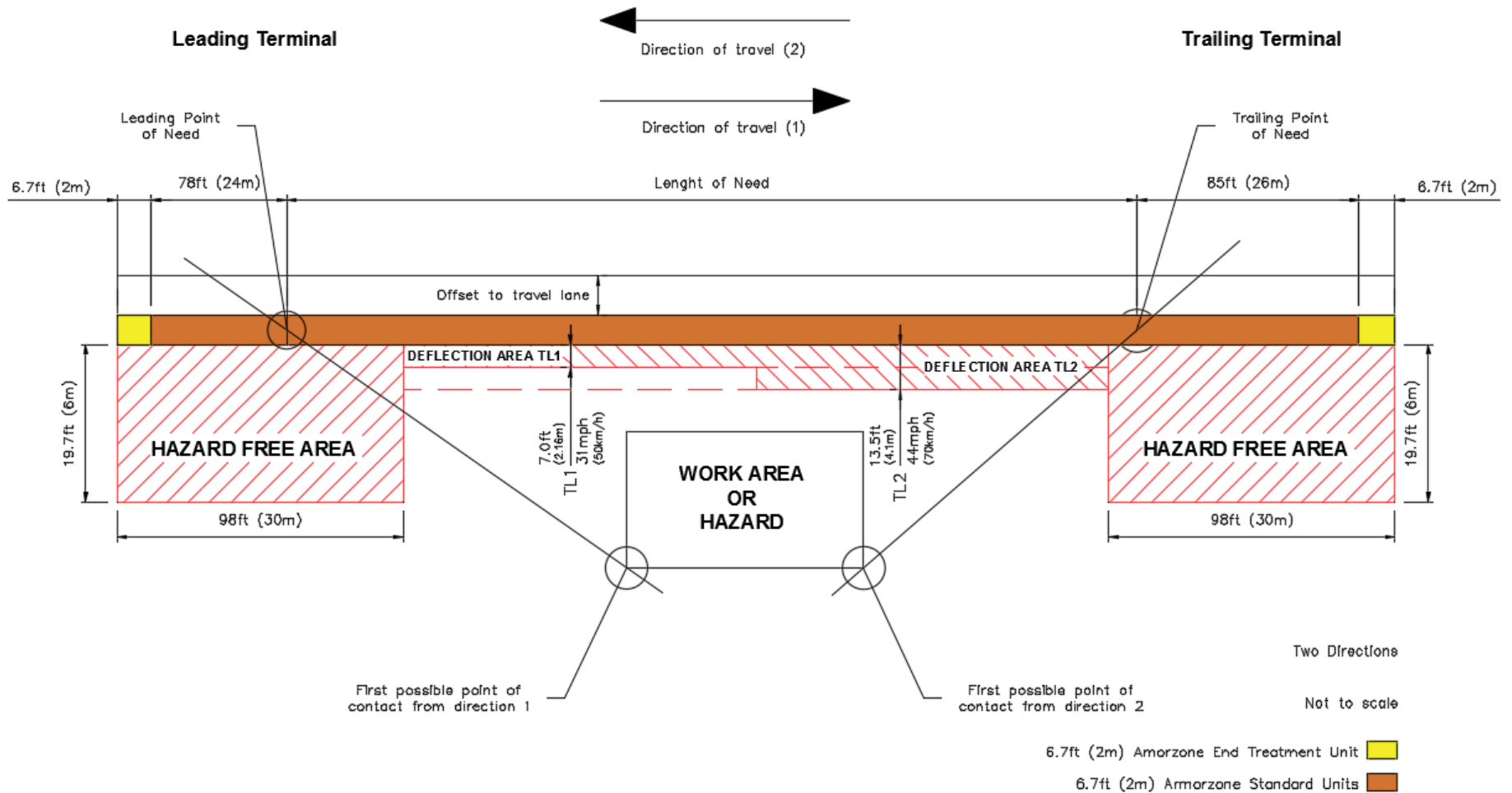

4.8 Deflection

Test 2-11 (MASH TL-2)

2270kg pickup truck, 25 degree angle at 70km/h (43mph)

Dynamic Deflection	Permanent Deflection
13.5' (4.10m)	13.5' (4.10m)

Test 2-10 (MASH TL-2)

1100kg car, 20 degree angle at 70kph (43mph)

Dynamic Deflection	Permanent Deflection
6.6' (2.02m)	6.6' (2.02m)

Note: Results are from actual crash testing and the test article length was 164' (50m). Results from Test 2-11 (MASH) are the published TL-2 Deflection.



MASH TL2 Compliant
70 km/h (43 mph)

161 1/2" (4100) Deflection Zone

5.0 PARTS IDENTIFICATION



Standard Unit
(HDPE)



End Treatment Unit
(HDPE)



Connector
(Hot Dipped Galvanised)

6.0 BILL OF MATERIALS

For every 6'-7" (2.0m) (linear) of temporary barrier the following components are required:

- **6'-7" (2.0m) ArmorZone® Standard Unit** 1 required
- **Steel Pin** 1 required
- **Water** 116 gal required (440L)
- **6'-7" (2.0m) ArmorZone® End Treatment Unit & Pin** Optional (water is not required)

7.0 INSTALLATION PREPARATION

7.1 Getting Started

It is essential that ArmorZone® barrier and ArmorZone® end treatment are installed correctly. Please carefully read and understand the following instructions before installing system.

Note: These instructions relate only to the installation of ArmorZone® and are for standard installations only.

ArmorZone® is designed so that it has exactly the same components and barrier setup whether in a 'roadside' or 'median' application. For all installations, commence placement of the units at one end and connect the units together until the correct barrier length and position is achieved. Please ensure that the checklists for both barrier and end treatment are completed for every installation.

7.2 Preparation

Before installing ArmorZone®, ensure that all components required for the system are on site and have been identified. ArmorZone® is a highly engineered safety device made up of a relatively small number of parts. Before starting installation ensure that one is familiar with the make up of the system. Refer to the Parts Identification and Bill of Materials section in this manual for more information.

Ensure that the area where ArmorZone® is to be installed is flat enough (max slope 10:1) and compacted, so that the ground conditions will not significantly alter the height of the vehicle in relation to the height of the barrier.

Minor site grading may be required.

7.3 Tools Required

There are no tools required to install the components of ArmorZone®. The units can be manually lifted and positioned by 2 personnel and the steel pin used to connect the units is simply dropped into position.

Each unit requires approx 116 gal (440L) of water and it is recommended that a large truck mounted tanker with large fill hose is sourced for fast barrier construction. The diameter of the 'fill hole' is 5" (125mm).



8.0 INSTALLATION INSTRUCTIONS

8.1 Step 1 – Site Preparation

It is preferred that ArmorZone® barrier is installed on compacted flat, level ground.

Ensure that sufficient width and traffic control is available before installing ArmorZone®. Due to the bulky nature of the units, deployment will be from a flat deck truck or similar. Each unit requires 116 gal (440L) of water and it is recommended that a large truck mounted tanker is used.

ArmorZone® barrier should be installed in a tangent position to the direction of travel.

ArmorZone® units are dispatched in bundles of up to 15. (shown in Figure 1) To ensure safe unloading of the units, use a fork hoist or similar to lower each row to ground level. From there each unit can be manually moved into position. (shown in Figure 2).



Figure 1: ArmorZone® units are dispatched in bundles of up to 15.

SAFETY STATEMENTS

General Safety

- All required traffic safety precautions should be complied with. All workers should wear required safety clothing. (high visibility vests, steel capped footwear, gloves etc.) Gloves should be worn at all times.
- Only authorized trained personnel should operate any machinery. Where overhead machinery is used, care must be taken to avoid any overhead hazards.

ArmorZone® Safety Statements

- All installers must be well clear of the water tanker when the units are being filled.
- ArmorZone® is a stand alone barrier and does not require at any stage during installation that the surrounding soil is dug or drilled in anyway.
- The empty units weigh 124 lbs (56kg) each and should be unloaded by 2 personnel. Do not attempt to lift a unit which contains water.
- Final positioning of the empty units and placement of the steel pin connectors should be done by 1 personnel so fingers are caught between the components.



Figure 2: Use a fork hoist or similar to lower each row to ground level.

8.2 Step 2 – Placement of the Barrier Units

Unload the units and set out in a row along the intended barrier position. Make sure the configuration of the ends will fit together where they join (shown in Figure 3).

Lifting the units is a 2 person job; they weigh 128lbs (58kg) each when empty.

Slide the units into position (shown in Figure 4).

The units must fit flush together so that the vertical holes on each unit line up (shown in Figure 5 & 6).

Note: If the drainage bung is on the workzone side of the barrier when assembled, it will allow for safe access when decommissioning the barrier.

Note: None of the units are fixed to the ground in any way.



Drainage Bung



Bung Spanner



Figure 3: When setting out, ensure the configuration of the ends will fit together.



Figure 4: Sliding the units into position.



Figure 5: Units are pushed together to align the vertical holes



Figure 6: The units must fit flush together so that the vertical holes on each unit line up.

8.3 Connecting the Barrier Units

Once the units are 'flush fit' aligned, the steel pin can be positioned down the 2 vertical alignment holes (shown in Figure 7 & 8).

The steel pin sits in the vertical holes under its own weight only and is not connected to the barrier units in any other way.

Note: If slight curvature of the barrier is required, position as required at this point.

8.4 Step 4 – Filling the Barrier Units

Lifting the flap on the top of the unit will allow access to the 5" (125mm) diameter water 'fill hole' (shown in Figure 9).

Using a truck mounted tanker fill each unit to the top with water (shown in Figure 10).

Check that there are no leaks before filling the next unit. If there is a leak the unit must be replaced. It may be possible to fix at a later stage depending on the damage.



Figure 7: Once the units are aligned, the steel pin can be dropped into the alignment holes.



Figure 8: Check the steel pin has gone through the alignment holes.



Figure 9: Lift the flap on the top of the unit to allow access to the water 'fill hole'.



Figure 10: Using a truck mounted tanker fill each unit to the top with water.



NOTE:
The ArmorZone® end treatment unit is never filled with water. Through design it is not possible to hold water through error or weather conditions.

8.5 Step 5 – Connecting the End Treatment Unit (Optional)

If protection is required for the end of the barrier, the ArmorZone® end treatment can be connected to the barrier in a tangent position.

Position the end treatment unit so that the lugs line up with the end barrier unit. Slide the unit into position so that the vertical holes line up (shown in Figure 11 & 12).

Once the units are 'flush fit' aligned, the 'twin pin' connector can be positioned down the 2 vertical alignment holes (shown in Figure 13 & 14).

Note: The end treatment unit is not and can not be filled with water.

The connector sits in the vertical holes under its own weight only and is not connected to the barrier units in any other way.

Note: The end treatment unit is NOT fixed to the ground in any way and must NOT have the 'twin pin' connector inserted at the exposed end of the unit.

8.6 Step 6 – Delineation (Optional)

Depending on location, delineation may be required as per the Road Controlling Authority Guidelines.

For further details contact your ArmorZone® distributor.



Figure 11: Position the end treatment unit so that the lugs line up with the end barrier unit.



Figure 12: Slide the unit into position so that the vertical holes line up.



Figure 13: Once the units are aligned, the steel pin can be dropped into the alignment holes.



Figure 14: Ensure the steel pin has gone through the alignment holes.

9.0 INSTALLATION EXAMPLES

Note: A minimum 92' (28m) radius curvature can be achieved when the 'flush fit' connection is made between ArmorZone® units. It is recommended that this positioning should be completed before the units are filled with water.



Straight Installation



Curved Installation



Installed End Treatment



Installed End Treatment

10.0 ArmorZone® Barrier & End Treatment

Location: _____

Installed By: _____

Date: _____

Signed: _____

Inspected By: _____

Date: _____

Signed: _____

Barrier		
The units are positioned on level ground	<input type="checkbox"/> Yes	<input type="checkbox"/> No
The set-out of the barrier is as per the design instructions	<input type="checkbox"/> Yes	<input type="checkbox"/> No
The lugs of each unit have a 'flush fit' with each other and the steel pin is positioned through both vertical holes in the lugs of each unit	<input type="checkbox"/> Yes	<input type="checkbox"/> No
The lid and bung are attached to each unit correctly so as to ensure the units will remain full of water as intended	<input type="checkbox"/> Yes	<input type="checkbox"/> No
Each unit is filled to the top with water. (approx 116 gal (440L)) Check for leaks	<input type="checkbox"/> Yes	<input type="checkbox"/> No
The barrier is not fixed to the ground or any other device in any way	<input type="checkbox"/> Yes	<input type="checkbox"/> No
Attach delineation as required by the Road Controlling Authority Guidelines	<input type="checkbox"/> Yes	<input type="checkbox"/> No
End Treatment	<input type="checkbox"/> Yes	<input type="checkbox"/> No
The ArmorZone® end treatment unit is connected to the ArmorZone® barrier using the twin pin steel connector through both vertical holes in the lugs of each unit	<input type="checkbox"/> Yes	<input type="checkbox"/> No
The end treatment unit is not and can not be filled with water	<input type="checkbox"/> Yes	<input type="checkbox"/> No
Do not install a twin pin connector at the upstream end of the end treatment unit	<input type="checkbox"/> Yes	<input type="checkbox"/> No
The end treatment unit is not fixed to the ground or any other device in any way	<input type="checkbox"/> Yes	<input type="checkbox"/> No
Attach delineation as required by the Road Controlling Authority Guidelines	<input type="checkbox"/> Yes	<input type="checkbox"/> No

Disclaimer:
Important Note: The conformity of the installation is the responsibility of the installation contractor, and Valmont Highway accepts no liability for or in connection with any installation that is outside of the specifications of this manual or the Road Controlling Authority. For more information, please refer to our Standard Terms and Conditions of Sale available on our website: www.ingalcivil.com.au.

11.0 REPAIR GUIDE

ArmorZone™ barriers can only be repaired if the damage sustained is in accordance with these guidelines. Not only is the size of repair important, but also the location.

Repair is only to make the barrier water-tight again. Any barriers which have structural damage must be discarded (recycled), as they cannot be used a vehicle barrier.

- Maximum permissible size of a repair is 2 inch (50mm) x 0.5 inch (12mm).
- Damage must be located between the green area indicated on diagram (shown below).
- Repair must be carried out by suitably trained personnel.
- Only HDPE plastic wire supplied by Valmont Highway to be used.

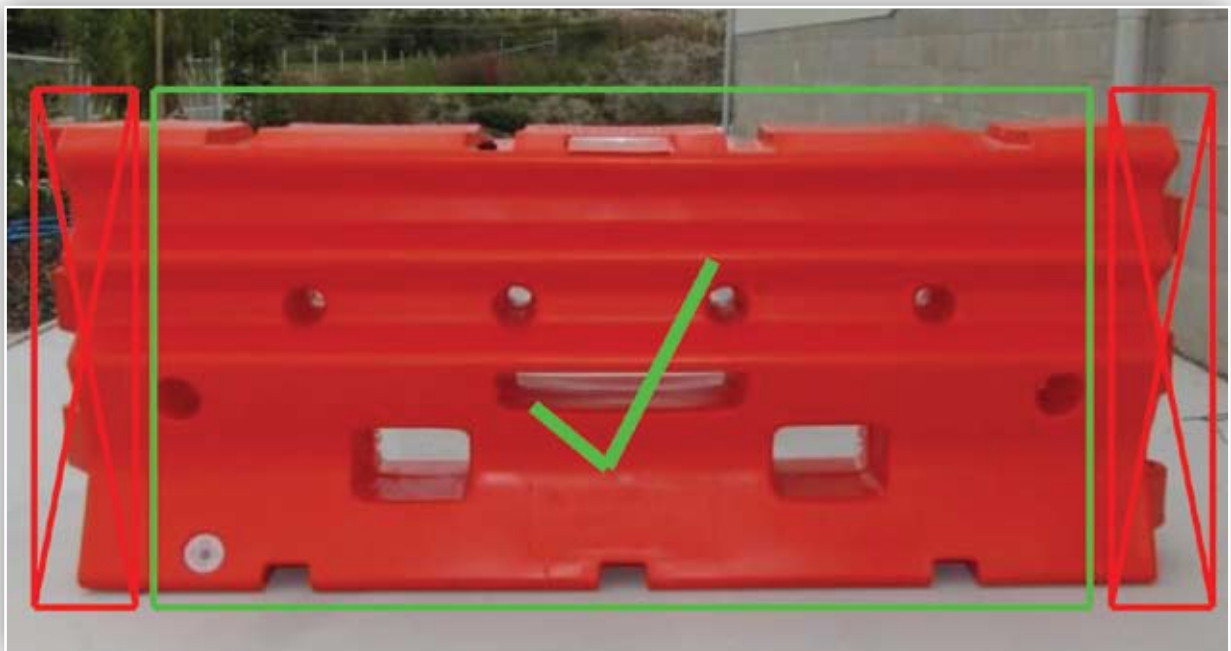

Damage must be located between the green area indicated above



Welder & HDPE Plastic Wire

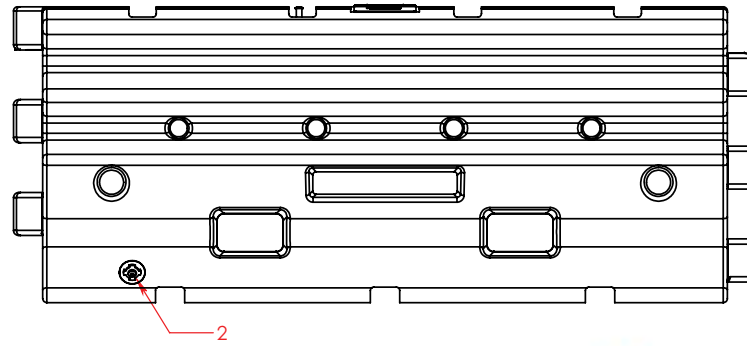
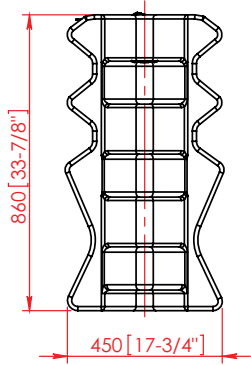

Note:
Steel Connector installed
Empty weight 56kg
Water volume 440 L
Full weight 496kg

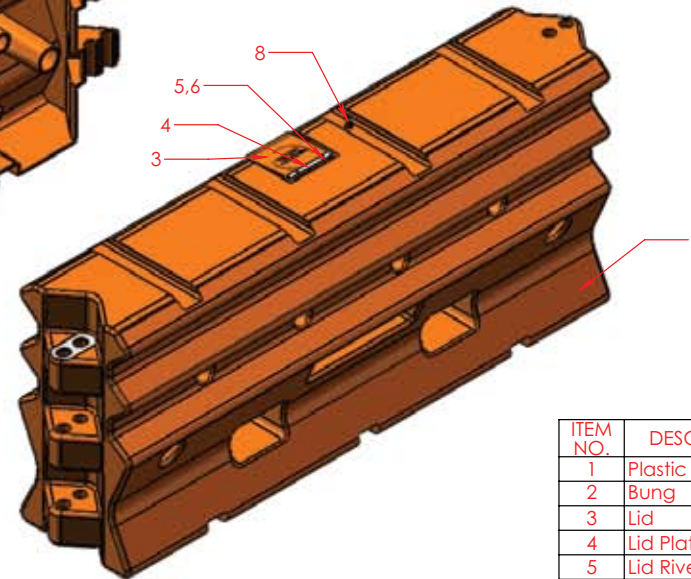
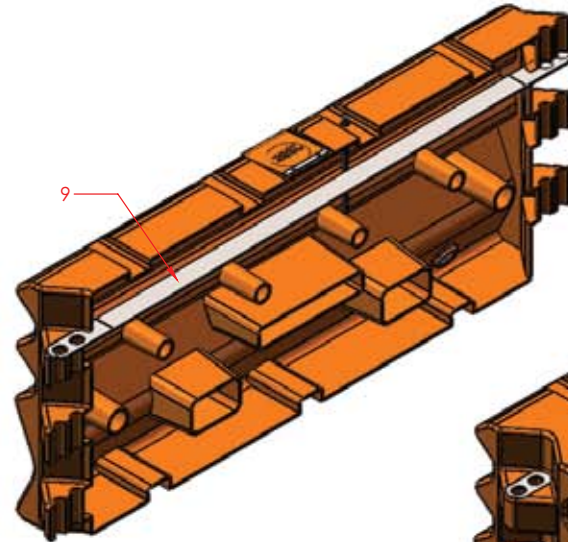
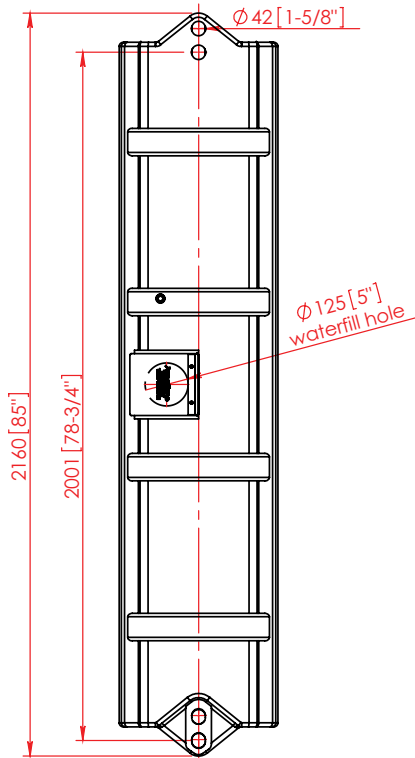
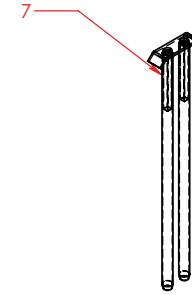

Note: All dimensions are nominal only. This is a rotomolded product and is therefore subject to shrinkage after manufacture so some variation in dimensions will occur. Further variances may be experienced depending on climatic conditions.

ITEM NO.	DESCRIPTION	QTY.
1	Plastic Shell	1
2	Bung	1
3	Lid	1
4	Lid Plate	1
5	Lid Rivet	2
6	Lid Washer	2
7	Reinforced Pin	1
8	Full Indicator	1
9	Steel Connector	1

The information heron is proprietary to Armorflex International Ltd. and shall not be disclosed, duplicated or used otherwise without the express written approval of Armorflex International Ltd.

SCALE: 1:20

Standard Tolerance

	DATE	INIT.
DRAWN BY	20/12/2010	AD
APPR'D BY	20/12/2010	DJ

valmont
HIGHWAY

57-65 Airds Road,
Minto NSW 2566
1800 251 420
info@valmonthighway.com

© 2010 Armorflex International Ltd.

REV.	CHANGES	DATE

ArmorZoneTM c/w steel

SHEET	DRAWING NUMBER	REV.
1 OF 1	P-AZ-A1S	

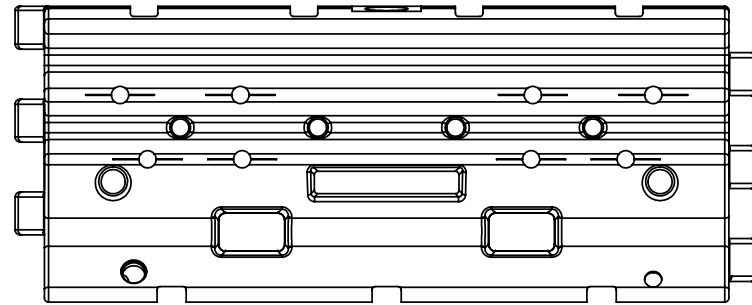
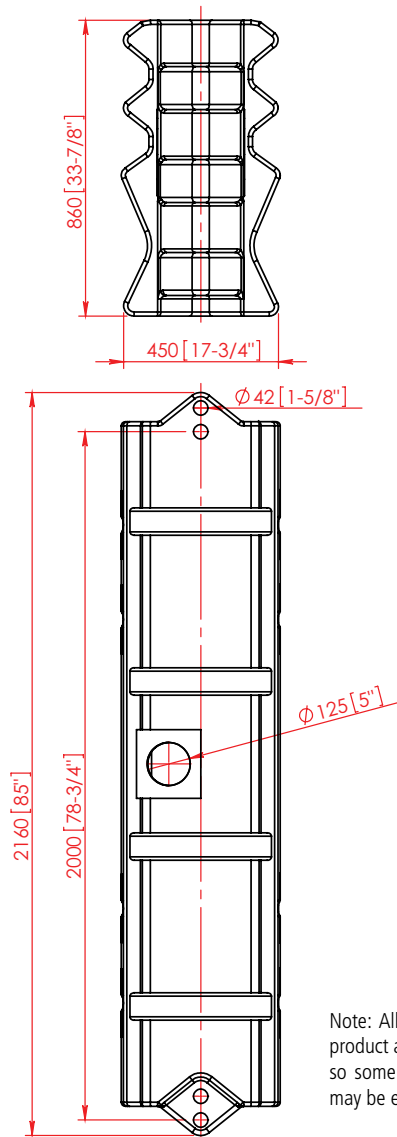

Note:
No Steel Connector inside
Weight 50kg

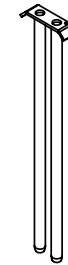
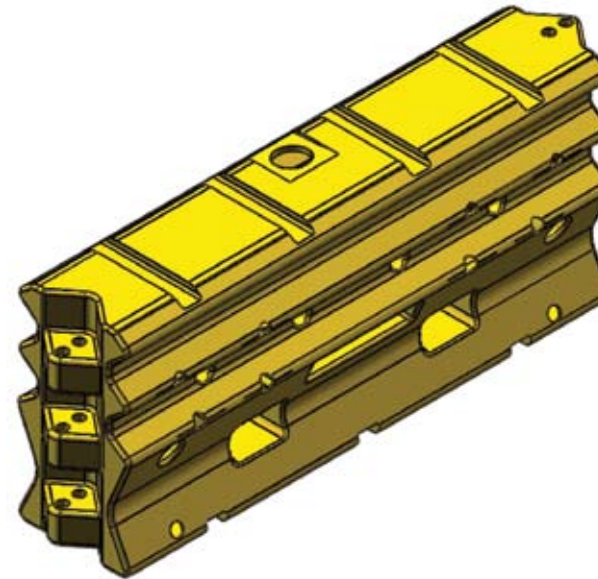

Note: All dimensions are nominal only. This is a rotomolded product and is therefore subject to shrinkage after manufacture so some variation in dimensions will occur. Further variances may be experienced depending on climatic conditions.

The information heron is proprietary to Armorflex International Ltd and shall not be disclosed, duplicated or used otherwise without the express written approval of Armorflex International Ltd.

SCALE: 1:20

Standard Tolerance

	DATE	INIT.
DRAWN BY	20/12/2010	AD
APPR'D BY	20/12/2010	DJ

valmont 
HIGHWAY

57-65 Airds Road,
Minto NSW 2566
1800 251 420
info@valmonthighway.com

© 2010 Armorflex International Ltd.

REV.	CHANGES	DATE

Armor Zone™ End Treatment

SHEET	DRAWING NUMBER	REV.
1 OF 1	P-ET-A1	



For more complete information on Valtir products and services, visit us on the web at www.valtir.com. Materials and specifications are subject to change without notice. Please contact Valtir to confirm that you are referring to the most current instructions.

WWW.VALTIR.COM
1.888.323.6374

