



CASS[®] S4 38" High

CABLE SAFETY SYSTEM

PRODUCT DESCRIPTION ASSEMBLY MANUAL

PN 628152

REVISION A APRIL 2023

CASS® S4 38” High CAble Safety System

The CASS® S4 38” High CAble Safety System (“CASS® S4(38)”), both 3-cable and 4-cable, has been tested to National Cooperative Highway Research Program (“NCHRP”) Report 350 criteria and has been deemed eligible for Federal-aid reimbursement on the National Highway System (“NHS”) by the Federal Highway Administration (“FHWA”) as a Test Level 3 (“TL-3”) and Test Level 4 (“TL-4”) system when installed on slopes which are 6:1 or flatter.

Product Description Assembly Manual



15601 Dallas Parkway
Suite 525
Addison, Texas 75001



Warning: The state/specifying agency, distributors, owners, and contractors are **RESPONSIBLE** for the assembly, maintenance, and repair of CASS® S4(38). Failure to fulfill these **RESPONSIBILITIES** with respect to the assembly, maintenance, and repair of CASS® S4(38) could result in serious injury or death.



Important: These instructions are for standard assembly specified by the appropriate highway state/specifying agency. **In the event the specified system assembly, maintenance, or repair would require a deviation from standard assembly parameters, contact a Valtir, LLC representative.** This system has been deemed eligible by the FHWA for use on the NHS under strict criteria utilized by that state/specifying agency.

This manual must be available to the worker overseeing and/or assembling the product at all times. For additional copies, contact Valtir at (888) 356-2363 or visit [Valtir.com/Products](https://www.valtir.com/Products).

The information contained in this manual supersedes all previous versions. The instructions, illustrations, and specifications are based on the latest CASS® S4(38) information available to Valtir at publication. We reserve the right to make changes at any time. Please visit [Valtir.com/product-category/barriers](https://www.valtir.com/product-category/barriers) to confirm the latest revision.

Table of Contents

CASS® S4(38) Acronyms.....	2
Customer Service Contacts	3
Important Introductory Notes	3
Limitation and Warnings	4
General CASS® S4(38) Information	6
CASS® S4(38) Components	6
Recommended Tools	15
Ground Preparation and Barrier Alignment.....	16
Line Posts Foundation Placement	17
CASS® S4(38) Cable End Treatment.....	19
CCT Posts Assembly.....	23
Terminal Cables	24
Line Cables	25
Laying Out the Cable/Attaching the Cables to the Posts.....	28
Tensioning and Tension Meter	30
Delineation	31
Repairs.....	32
Emergency Repairs	33
Cable Tension Inspection Program.....	35
CASS® S4(38) Assembly/Repair Checklist	36
CASS® S4(38) Routine Inspection Checklist (File with Maintenance Records)	37
CASS® S4(38) Temperature/Tension Chart	38
3 Cable Tension Log Cable Safety System.....	39
4 Cable Tension Log Cable Safety System.....	40
Appendix A: Flare Assemblies 30:1 Flare	41
Appendix B: Cable Barrier Overlap	42
Appendix C: Encountering Rock	43
Appendix D: Base Plated Post Assembly	44

CASS® S4(38) ACRONYMS

AASHTO	American Association of State Highway and Transportation Officials
CASS® S4(38)	The CASS® S4 38"High Cable Safety System
CBOD	Cable Barrier Overlap Distance
CCA	CASS® Cable Anchor
CCT	CASS® Cable Terminal
CFR	Code of Federal Regulation
CRP	Cable Release Post
FHWA	Federal Highway Administration
MSC	Minimum Strength Concrete
MUTCD	Manual on Uniform Traffic Control Devices
NCHRP	National Cooperative Highway Research Program
NHS	National Highway System
OSHA	Occupational Safety & Health Administration
PN	Valtir Part Number
PPE	Personal Protective Equipment
TL-3	Test Level-3
TL-4	Test Level-4
Valtir	Valtir, LLC
1V:"x"H	Slope Measurement-1 Foot Vertical Distance to "x" Foot Horizontal Distance

Customer Service Contacts

Valtir is committed to the highest level of customer service. Feedback regarding CASS® S4(38) its assembly procedures, supporting documentation, and performance is always welcome. Additional information can be obtained from the contact information below:

Valtir

Telephone	(888) 356-2363 (USA) +1 214 589 8140 (International)
Contact Link	Valtir.com/Contact
Website:	www.Valtir.com

Valtir, LLC

15601 Dallas Parkway

Suite 525

Addison, TX 75001

Important Introductory Notes

Proper assembly of CASS® S4(38) is essential to achieve the performance that has been evaluated and deemed eligible for federal-aid reimbursement by the FHWA per NCHRP Report 350. These instructions are to be read in their entirety and understood before assembling CASS® S4(38). These instructions are to be used only in conjunction with standard CASS® S4(38) assemblies specified by the state/specifying agency. **If you need additional information, or have questions about CASS® S4(38), please contact the state/specifying agency that has planned and specified this assembly and, if needed, contact Valtir Customer Service.** This product must be assembled in the location specified by the state/specifying agency. If there are deviations, alterations, or departures from the assembly instructions specified in this manual, the device may not perform as tested.

Note: The Metric conversion from Imperial in this manual uses a soft conversion.

The state/specifying agency's careful evaluation of the site layout, vehicle population type and speed, traffic direction, and visibility are some of the elements that require evaluation in the selection of a highway product. For example, curbs could cause an untested effect on an impacting vehicle.

A set of product and project shop drawings will be supplied by Valtir. The shop drawings will be for each section of the assembly. These drawings are to be reviewed and studied thoroughly by a qualified individual who is skilled in interpreting them.

Limitations and Warnings



Valtir, in compliance with NCHRP Report 350, contracts with ISO 17025 A2LA accredited testing laboratories to perform crash tests, evaluate tests, and submit the test results to the FHWA for review.

CASS® S4(38) has been deemed eligible by FHWA as meeting the requirements and guidelines of NCHRP Report 350, Test Level 4. These tests typically evaluate product performance defined by NCHRP Report 350 involving a range of vehicles on roadways, from lightweight cars (approx. 800 kg [1800 lb.]) a full size pickup trucks (approx. 2,000 kg [4,400 lb.]) at 100 kph [62 mph], and a single-unit van truck, approx. 8,000 kg [18,000 lb.] at approximately 80 kph [45 mph].

CASS® S4(38) is tested pursuant to the test matrix criteria of NCHRP Report 350 TL-4(38) as designated by FHWA. The FHWA tests are not intended to represent the performance of systems when impacted by every vehicle type or in every impact condition existing on the roadway. Every departure from the roadway is a unique event.

Valtir expressly disclaims any warranty or liability for injury or damage to persons or property resulting from any impact, collision or harmful contact with its products, other vehicles, or nearby hazards or objects by any vehicle, object or person, whether or not the products were assembled in consultation with Valtir or by third parties.

CASS® S4(38) is intended to be assembled, delineated, and maintained within specific state and federal guidelines. It is important for the state/specifying agency specifying the use of a highway product to select the most appropriate product configuration for site specifications.

The state/specifying agency's careful evaluation of the site layout, vehicle population type and speed, traffic direction, and visibility are some of the elements that require evaluation in the selection of a highway product. For example, curbs could cause an untested effect on an impacting vehicle.

After an impact with the system, all debris must be removed from the area immediately in compliance with the most applicable state/specifying agency policy. The specified CASS® S4(38) must be evaluated and restored to its original specified condition or replaced as the state/specifying agency determines/requires, as soon as possible. Product selection, approval, proper installation, and maintenance of any highway product is the sole responsibility of the state/specifying agency.

Safety Alert Symbols appear throughout this manual and indicate **Danger, Warning, Caution or Important** statements. Failure to read and follow these warnings could result in serious injury or death in the event of a vehicle impact with the system.

WARNING: Do not assemble, maintain, or repair CASS® S4(38) until you have read this manual thoroughly and completely understand it. Ensure that all **Danger, Warning, Caution, and Important** statements within the manual are completely followed. Please call Valtir at (888) 356-2363 if you have any questions about instructions in this manual.

WARNING: Safety measures incorporating appropriate traffic control devices and personal protective equipment ("PPE") specified by the highway state/specifying agency must be used to protect all personnel while at the assembly, maintenance, or repair site.

WARNING: Ensure the assembly site meets all appropriate **Manual on Uniform Traffic Control Devices ("MUTCD")** and local standards.

WARNING: Only Valtir parts that are specified herein can be used for assembly, maintenance, or repair on CASS® S4(38). **Do not utilize or commingle parts from other Valtir systems.** Alternate configurations have not been tested, nor have they been approved for use. Assembly, maintenance or repairs using unspecified parts or accessories is strictly prohibited. Failure to follow this warning could result in serious injury or death in the event of a vehicle impact with such an UNACCEPTED system.

WARNING: Do NOT modify CASS® S4(38) in any way.

IMPORTANT: Valtir makes no recommendation whether use or reuse of any part of CASS® S4(38) is appropriate or acceptable after system impact. It is the responsibility of the local highway state/specifying agency and its engineers to make that determination.

IMPORTANT: It is the responsibility of the applicable owner, state/specifying agency, or specifier to inspect CASS® S4(38) after assembly is complete to ensure the instructions provided in this manual have been strictly followed.

Danger: It is critical that CASS® S4(38) posts are placed in suitable soil that will allow the system to fully perform in accordance with design specifications. Should you have any questions about this, please contact the state/specifying agency that specified CASS® S4(38) at this particular location for guidance. Valtir is available for consultation with that state/specifying agency.

Note: Based on soil conditions at the site, ANY or ALL foundations may need larger/deeper concrete footings or larger soil plates (for driven applications) as determined by soil analysis.

Warning: Do not allow pedestrians or workers to stand near this system, when under tension, in circumstances where the cable may be impacted or cut. Failure to follow this warning can result in serious injury or death to the workers, bystanders and/or pedestrians in the event of a vehicle impact with the system.

Warning: It is imperative, before assembly, that you contact a Valtir representative and highway state/specifying agency engineer for special criteria for soils which do not meet or exceed NCHRP Report 350 soil conditions. It is also recommended that you consult your own geotechnical engineer.

Warning: Be aware of hazards of using compressed air (small objects may become projectiles). Failure to follow this warning can result in serious injury or death to the workers and/or bystanders.

Warning: When drilling rock, it is the responsibility of the installer to consult Occupational Safety & Health Administration (“OSHA”) silica respiratory standard 29 Code of Federal Regulation (“CFR”) 1910.134 for debris removal and ensure compliance.

Warning: Ensure that CASS® S4(38) delineation used meets all federal, state, specifying state/specifying agency, and local specifications.

Warning: CASS® S4(38) shall be placed on a median or roadside without obstructions, depressions, etc. that may significantly affect the stability of an errant vehicle. Grading of the site and/or appropriate fill materials may be required. The assembler shall “flatten” or “round” various topographical inconsistencies that could interfere with the ability to consistently maintain the design height (in relation to the terrain) of the cables. To address assembly in rock, see Appendix C: Encountering Rock.

General CASS® S4(38) Information

CASS® S4(38) is a 3 or 4 Cable Barrier consisting of a 4" wide galvanized steel S4 x 7.7# [S100 x 11.5] and three (3) or four (4) pre-stretched 3/4" [19 mm] wire rope cables. The posts can be driven, placed in a driven sleeve, placed in a sleeve and concrete footing, placed in a sleeve in a mow strip, or base plated. One inch [25 mm] or 3/4" [19 mm] fitting hardware can be used. CASS® S4(38) can be used as a TL-3 / TL-4 system on 1V:6H or flatter slopes.

The post spacing range is 6'-6" [2 m] minimum and 32'-6" [9.9 m]. The 12" x 30" diameter [300 mm x 762 mm] minimum depth concrete footing is used for the system with slopes 1V:6H or flatter. See the Ground Preparation Section for additional placement criteria. The footing depths/diameters can be increased if the soil characteristics do not meet NCHRP Report 350 standard soil. Contact Valtir for these designs.

CASS® S4(38) can be placed on the roadside in front of slopes 1V:2H or flatter. Use a minimum distance of 2' [0.6 m] in front of the hinge point to the center of the post.

All cable height dimensions are approximate from top of grade to center of cable. Cables are placed in a slot at the top of the posts at approximate heights are of 20.9" [530 mm], 29.5" [750 mm], and 38.1" [968 mm] for the three (3) cable CASS® S4(38); 20.9" [530 mm], 25.2" [640 mm], and 29.5" [750 mm] and 38.1" [968 mm] for the four (4) CASS® S4(38). Plastic spacers keep the cables positioned at approximately 4" [100 mm] or 8" [200 mm] on center, from each other. A stainless steel strap is placed around the post below the top cable.

The post spacing will be in accordance to the contract plans. The barrier is terminated either with a CCT, or a CCA. **Only use the CCA when not on the NHS or when it cannot be impacted in either direction.**

The Minimum Strength Concrete ("MSC") for all concrete components of CASS® S4(38) is 3,000 psi [21 MPa] or greater to meet the state/specifying agency's specifications.

Inspect Shipment

Before assembling the CASS® S4(38), carefully unpack and inspect all components for signs of damage. Check the received parts against the packing list supplied with the system to verify that all parts were received. If parts are damaged or missing from the shipment or unspecified parts were part of the shipment, do not attempt to assemble the system; contact Valtir immediately.







Warning: Use only Valtir parts that are specified by Valtir for use with the CASS® S4(38) for assembling, maintaining, or repairing the CASS® S4(38). Do not utilize or otherwise commingle parts from other systems even if those systems are other Valtir Systems.

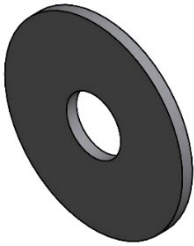
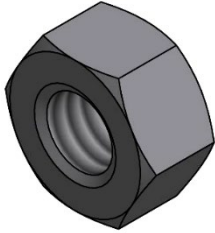

CASS® S4(38) Components

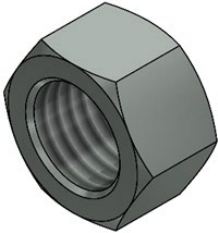

Below is a pictorial of components for the **CASS® S4(38)** hardware. Please see **Valtir drawing** for specific lists of quantities. All Valtir Part Numbers ("PN") are provided for standard parts only.



Note: The following components are not shown to scale.

PN: 3240G	PN:3245G	PN: 3300G
		
5/16" Flat Washer (F844)	5/16" Hex Nut (A563)	5/8" Flat Washer (F844)

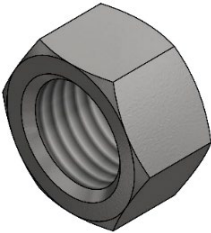
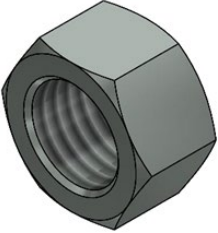
PN: 3310G	PN: 3361G	PN: 3536G
		
5/8" Lock Washer	5/8" Hex Nut	1" Stud Flattened-RHT

PN: 3537G	PN: 3700G	PN: 3701G
		
1" Stud Flattened-LHT	3/4" Flat Washer	3/4" Flat Washer (F436)

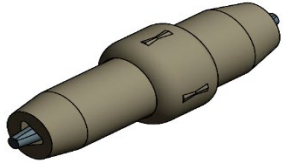
PN: 3710G	PN: 3711G	PN: 3908G
		
3/4" Hex Nut (A563)	3/4" Hex Nut (A194 2H)	1" Heavy Hex Nut (A563 DH)

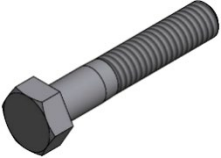
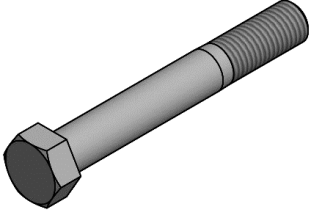
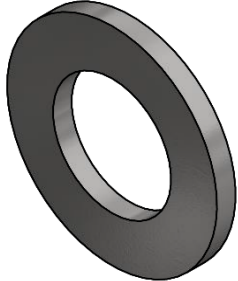

PN: 4099G	PN:4190G	PN: 4199B
		
Torpedo Cable Splice	Cable End Casting	3/4" Cable Wedge (3 x 7)

PN: 4211G	PN: 4779G	PN: 4902G
		
5/16" x 1-3/4" Hex Bolt (A307)	3/4" x 4-1/2" Hex Bolt (A325)	1" Flat Washer (F436)

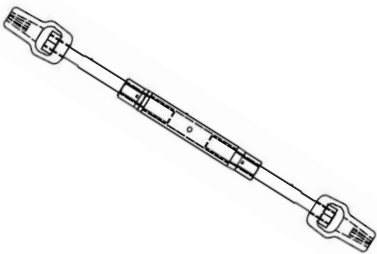
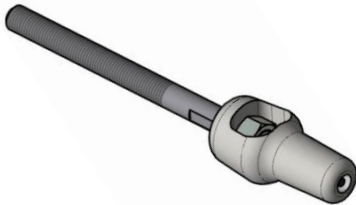
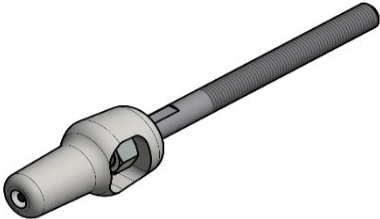

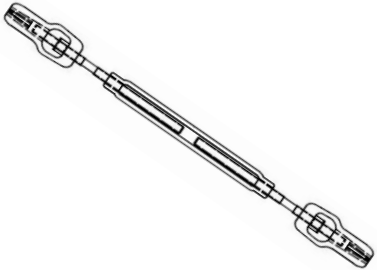
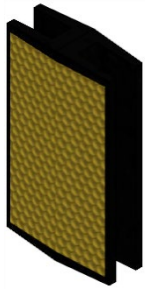
PN: 4903G	PN: 4959G	PN: 5225G
		
1" Hex Nut (A194 2H)	3/4" Heavy Square Nut	5/8" X 7-1/2" HAS SUPER Rod Chisel Pt (A193 B7)

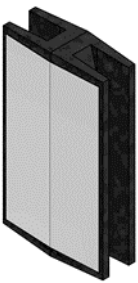
PN: 5633G	PN: 5634G	PN:5635G
		
Assembled 1" Cable Splice	3/4" Cable Field Splice Left	3/4" Cable Field Splice Right

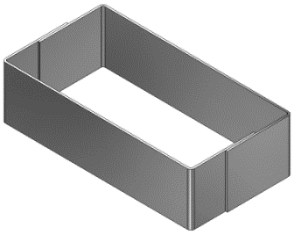
PN: 5700B	PN: 5698G	PN: 5701B
		
4" Cable Spacer w/o Reflector	Assembled 3/4" Cable Splice	4" Cable Reflector Spacer Yellow

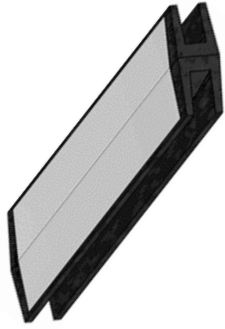

PN: 5702B	PN: 5705B	PN: 5707T
		
4" Cable Reflector Spacer White	8" CASS® TL-4 Yellow Reflector Spacer	Stainless Steel Post Strap



PN: 5708B	PN: 5709B	PN: 5711G
		
Sleeve Cover – CASS® S4 TL-4 Post	CASS® Thermometer (Infrared)	3/4" Turnbuckle - Open Body

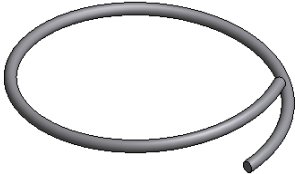
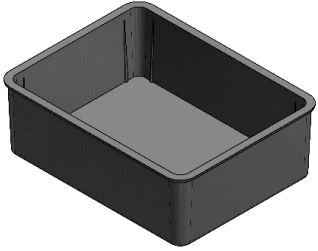

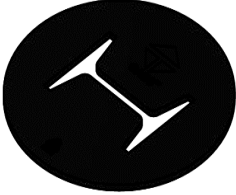
PN: 5720B	PN: 5724B
	
8" CASS TL-3 White Reflector Spacer	Post Cap-CASS TL-3 Post



PN: 5747B	PN: 5703B	PN: 5825G
		
CASS® TL-3 Sleeve Cap, Bottom	8" CASS® TL-4 Spacer	Cable Lock Bolt (A307)

PN: 5826G	PN: 5836B	PN: 5837B
		
1" Turnbuckle - Closed Body	8" Concrete Reinforcing Ring	S3 Sleeve Cap Bottom

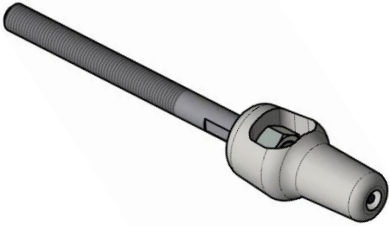
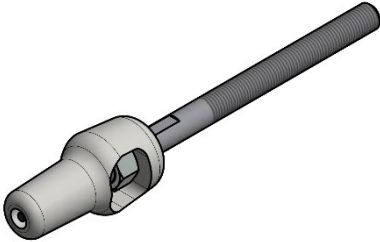
PN: 5839B	PN: 5840G	PN: 5850B
		
S3 Sleeve Cover Terminal Post	5'-0" Cable Field Repair Section	CASS® Cable Pulling Tool

PN: 5851B	PN: 5852B	PN: 5878B
		
Reflector Median (LEFT)	Reflector Roadside (RIGHT)	CASS® Tension Meter



PN: 5909G	PN: 5910G	PN: 5919B
		
1" Cable Field Splice Left	1" Cable Field Splice Right	#4 x 2'-8" Rebar Rod

PN: 6722G	PN: 9021G	PN: 33903A
		
5/8" X 8" ATR CHSL PT A449	Bearing Angle	Driven S3 Terminal Posts w/Soil Plates-Posts 4-7

<p>PN: 33908G</p>  <p>Terminal Post Sleeve-S3 Post</p>	<p>PN: 33909G</p>  <p>CRP-Cable Bracket</p>	<p>PN: 33910G</p>  <p>S3 Terminal Post – in Sleeve Posts 4-7</p>
<p>PN: 33916B</p>  <p>CRP Reinforcing Cage</p>	<p>PN: 33934A</p>  <p>Bottom CRP (in Concrete)</p>	<p>PN: 33935A</p>  <p>Top CRP</p>
<p>PN: 33936A</p>  <p>Bottom CRP (w/Soil Plate)</p>	<p>PN: 33952A</p>  <p>Driven Terminal Sleeve w/Soil Plates- S3 Posts 4-9</p>	<p>PN: 33954G</p>  <p>CASS® TL-4 Post in Sleeve</p>

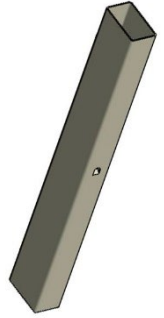
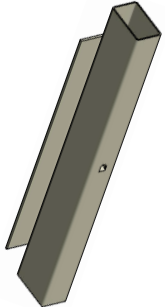
PN: 33955G	PN: 33957G	PN: 33968G
		
S3 Terminal Post – in Sleeve Posts 8-9	CASS® TL-4 Driven Post	15” CASS® Post Sleeve

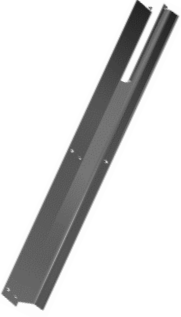
PN: 33974G	PN: 33975G	PN: 33976A
		
CASS® TL-4 Splice Post (In Sleeve)	30-3/4” Driven CASS® TL-4 Post Sleeve	30-3/4” CASS® TL-4 Driven Sleeve w/Soil Plate

PN: 33982G	PN: 33984G	PN: 33989A
		
27” CASS® TL-4 Post Sleeve	CASS® TL-4 Splice Post (Driven)	Driven S3 Terminal Posts w/Soil Plates-Posts 8-9

PN: 33994A	PN:105204G	PN: 105205G
		
CASS® TL-4 Base Plated Post	3/4" Stud Flattened-LHT	3/4" Stud Flattened-RHT



Important: Valtir makes no recommendation whether use or reuse of any part of the system is appropriate or acceptable following an impact. It is the sole responsibility of the local highway state/specifying agency and its engineers to make that determination. It is critical that you inspect this product after assembly is complete to make certain that the instructions provided in this manual have been strictly followed.

Recommended Tools

Documentation

- Manufacturer's **CASS® S4 38" High CAble Safety System** Product Description Assembly Manual (Current Version).
- **CASS® S4(38) System Drawing(s)**. Current Versions of SS740 TL-4 6:1 3C or 4C.

Personal Protective Equipment (PPE)

- Eye Protection
- Work Gloves
- Back Protection
- Safety-Toe Shoes
- Reflective Vest
- Apron

Wrenches

- Pipe Wrenches
- Adjustable Spanner
- Adjustable Jaw Wrenches
- Imperial and Metric Wrenches

Concrete equipment

- Concrete Vibrator
- Concrete Tools

Cable/Miscellaneous equipment

- Traffic Control Equipment and Plan per local standards and the MUTCD
- Cable Tension Meter (PN-5878B)
- CASS® Thermometer (Infrared) (PN-5709B)
- Abrasive Cutoff Blade/Saw
- C-Clamps
- CASS® Cable Pulling Tool (PN-5850B)
- Locking Pliers
- Duct tape
- Pry Bars
- Line/String
- Plumb Line
- Straight Edge
- Level
- Drift Pin
- Tape Measure
- Come-along/Lever chain hoist (3 ton minimum capacity)
- Backhoe (optional tensioning device)
- Marking Paint
- Post Pounder
- Auger

Note: The provided list of tools is a general recommendation and should not be considered an extensive list. Depending on specific site conditions and the complexity of the assembly specified by the state/specifying agency, the required tools may vary. Decisions as to what tools are needed to perform the job are entirely the responsibility of the specifying state/specifying agency and the state/specifying agency's selected contractor performing the assembly of the system at the state/specifying agency's specified assembly site.

Ground Preparation and Barrier Alignment

CASS® S4(38) shall be placed on a median or roadside without obstructions, depressions, etc. that may significantly affect the stability of an errant vehicle. Grading of the site and/or appropriate fill materials may be required. The assembler shall “flatten” or “round” various topographical inconsistencies that could interfere with the ability to consistently maintain the design height (in relation to the terrain) of the cables. To address assembly in rock, see Appendix C: Encountering Rock.



Warning: It is imperative, before assembly, that you contact a Valtir representative and state/specifying agency engineer for special criteria involving soil conditions not meeting or exceeding NCHRP Report 350 soil conditions. It is also recommended that you consult your own soils or structural engineer.

Note: Based on soil conditions at the site, either CCT or CCA may need larger/deeper concrete footings or larger soil plates (for driven applications) as determined by soil analysis

Ground Preparation

When CASS® S4(38) is placed in a median, use the following criteria for locating the system:

Ensure that the finished grade (side slope) is 1V:6H or flatter.



FHWA and AASHTO guidance for ANY NCHRP Report 350 cable system placed on side slopes steeper than 1V:10H shall not be placed within 1' to 8' [0.3m to 2.4m] from the ditch line.

Barrier Alignment

Follow all procedures in the placement of the footing and/or post to ensure proper alignment. It is suggested that a string line or other means be used to provide a consistent horizontal and vertical alignment that meets specifications. If assembled on a horizontal curve, a minimum 650 foot [198 m] radius is required. If assembled on a sag vertical curve, the K value is $\geq 100'$ [30 m]. See “Assembly on a Curve” Section.

CASS® S4(38) can be placed on the roadside in front of slopes 1V:2H or flatter. Use a minimum distance of 2' [0.6 m] in front of the hinge point to the center of the post.

Use the state/specifying agency’s guardrail terminal standards for grading and widening for the CCT.

There may be instances where a break will be required in the cable run. In these circumstances proper overlap of the terminals is required in order to prevent a vehicle from passing through the protected area. Depending on the location of the cable with respect to the direction of traffic, there are two situations which can occur. See Appendix B for recommended overlaps.



Important: A flare rate of 30:1 or flatter is required if the barrier must be flared, transverse across the median, or if CASS® S4(38) must have a change in direction (See Appendix A).

Assembly on a Curve

Horizontal Curve

Complete the following steps to place the posts or post foundations along a curve.

1. When the cable is placed on a curve, post spacing may need to be reduced based on the radius.
2. Weak soil conditions may necessitate a larger/deeper footing for the line posts, based on the radius of the curve.
3. When placing posts on a curve, use the table below to adjust the spacing as required:

Curve Radius	Post Spacing
0 to 650'	CASS® S4(38) is not recommended.
650' to 1300' [198 m to 396 m]	10'-6" [3.20 m] post spacing or less (as specified by the state/specifying agency)
Greater than 1301' [396 m]	32'-6" [9.91 m] post spacing or less (as specified by the state/specifying agency)

Note: If any of the post spacing for a particular radii grouping is larger than the contract specifications, use the contract specification post spacing.

Vertical Curve

For a sag vertical curve, the recommended minimum K value is 100' [30]. There is no K value limit for crest vertical curves.

$$K = L / (g_1 - g_2)$$

L = length of vertical curve in feet [meters] between the two tangents

g_1 = grade of tangent in

g_2 = grade of tangent out

When the minimum sag vertical curve value is not met, the use of intermediate terminals at the low point of the sag curve is recommended to minimize the cables from rising beyond the allowable height tolerance relative to grade.

Line Post Foundation Placement



Warning: If the post cannot be placed, pursuant to these assembly instructions, because of soil conditions, or any other environmental factor, please contact the specifying highway state/specifying agency immediately! NEVER attempt to place posts if these assembly instructions cannot be complied with.

Post Alignment

Lay out the post alignment and post spacing according to the contract specifications. CASS® S(38) maximum post spacing for the three (3) and four (4) cable system is 32'-6" [9.9 m].

Driven Foundation Sleeve With and Without Soil Plate

Complete the following steps for a driven foundation sleeve assembly.

1. Drive the foundation sleeve (PN-33975G) or foundation sleeve with soil plate (PN-33976A) with an appropriate driving head. During the driving process ensure that the sleeve is aligned, properly oriented (with interior tabs 15" [375 mm] from the top of the tube sleeve and the 3" [75 mm] side parallel to the roadway), soil is prevented from coming up into the sleeve, and the sleeve is not damaged.

Sleeve in Poured Concrete Footing

Complete the following steps for placing a sleeve in a poured concrete footing.

1. Place a plastic cap (PN-5747B) on the bottom of the foundation sleeve (PN-33982g) or tape the bottom end of the foundation sleeve to prevent the concrete from coming into the tube.
2. Punch or auger a minimum 12" [300 mm] diameter x 30" [762 mm] deep hole for the concrete footing.
3. Pour the MSC in the hole ensuring the concrete is flush with the finish grade.
4. Place the foundation sleeve in the poured concrete footing. Ensure that the sleeve is positioned plumb, flush with the top of the footing, properly oriented (with interior tabs 15" [375 mm] from the top of the tube sleeve and the 3" [75 mm] side parallel to the roadway), and in alignment. Consolidate the concrete to remove air pockets in compliance with applicable state specifications for similar applications.
5. Place a rebar ring (PN-5836B) around the top of the sleeve 2" to 3" [50 mm to 75 mm] from the top of the footing.
6. Smooth off the top of the concrete footing with a slight crown from the sleeve.
7. Allow the footing to attain the required concrete strength before disturbing the foundations, including the placement of posts.

Sleeve in Mow Strip

When a mow strip is used that meets the criteria in drawing SS 740, sleeve (PN-33968G) may be used.

Complete the following steps for placing a sleeve in a mow strip.

Footings utilized with a qualified Mow Strip Assembly

1. Place a plastic cap (PN-5747B) on the bottom of the foundation sleeve (PN-33968G) or tape the bottom end of the foundation sleeve to prevent the concrete from coming into the tube.

Monolithic Pour:

- A. Punch or auger a minimum 12" [300 mm] diameter hole, 24" [600 mm] deep for the concrete footing. The MCS will be placed in the hole as part of the mow strip poured.
- B. Proceed to step 3 below.

Footings Placed after the Construction of the Mow Strip:

- A. Place leave-out material at each footing location in the strip to allow the footing hole to be augered or punched after the mow strip is constructed.
- B. Proceed to step 3 below.
2. Pour the MSC.
3. Consolidate the concrete to remove air pockets in compliance with applicable state specifications for similar applications.
4. Place the foundation sleeve plumb and in alignment with the string line, ensuring a minimum of 3" [75 mm] of concrete surrounds the sleeve on all sides, and the top is flush with the top of the concrete footing.
5. Smooth off the top of the concrete footing with a slight crown from the sleeve.
6. Allow the footing to attain the required concrete strength before disturbing the foundations, including the placement of posts.

Precast Concrete Footings

The precast concrete footings will be fabricated in forms and installed the same as if placed in an augured or punched hole.

Post Placement

Posts

CASS® S4(38) posts can be driven, placed in a driven sleeve, placed in a sleeve in a concrete footing (poured or precast), or mounted to a concrete surface.

Driven Posts

Complete the following steps for a driven post assembly.

1. Lay out the post alignment and post spacing according to contract specifications and drive the post (PN-33957G) with an appropriate driving head equipment.
2. The height from the finished grade to the top of the post is approximately 3'-4 7/8" [1.04m].

Posts in Sleeve

Complete the following steps for a post in the sleeve assembly

1. Place the post sleeve cover (PN-5823B) on the bottom end of the CASS® S4(38) post(s) (PN-33954G or 33974G).
2. Place the post in the sleeve so it rests on the first tab in the sleeve or bottom of the sleeve and the sleeve cover is located at the top of the sleeve.
3. The height from the finished grade to the top of the post is approximately 3'-4 7/8" [1.04m].

Base Plated Post

For Base Plated Post Assembly, see Appendix D.

CASS® S4(38)Cable End Treatments

CASS® S4(38) is terminated with either a CCT or a CCA.

CCT

For the three (3) cable system, the CCT consists of three (3) CRP (Bottom CRP and Top CRP Post) and six (6) S3 x 5.7# [S75 x 8.5] terminal line posts; for the four (4) cable system, the CCT consists of four (4) CRP (Bottom CRP and Top CRP Post) and six (6) S3 x 5.7# [S75 x 8.5] terminal line posts. The cables are terminated at the CRP, one at each post. The terminal line posts are placed with sleeve in a concrete footing, a sleeve with a soil plate, or a driven post with a soil plate.

For the CRP footing locations and spacing, see Figure 1a for three (3) Cable System or 1b for four (4) Cable System.

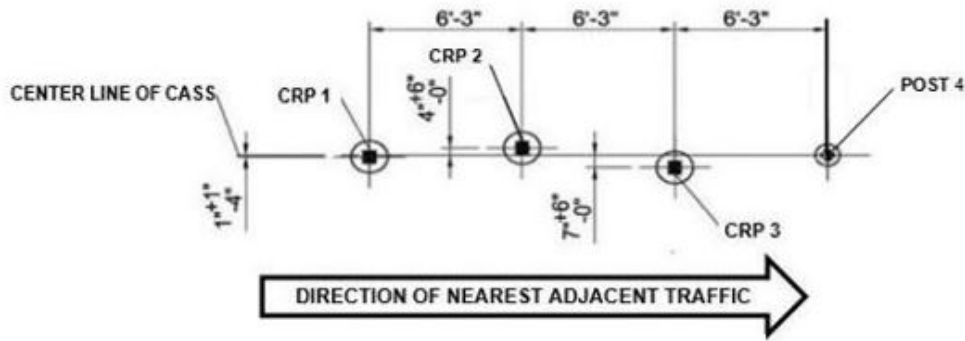

Figure 1a
CRP Offset 3 Cable system

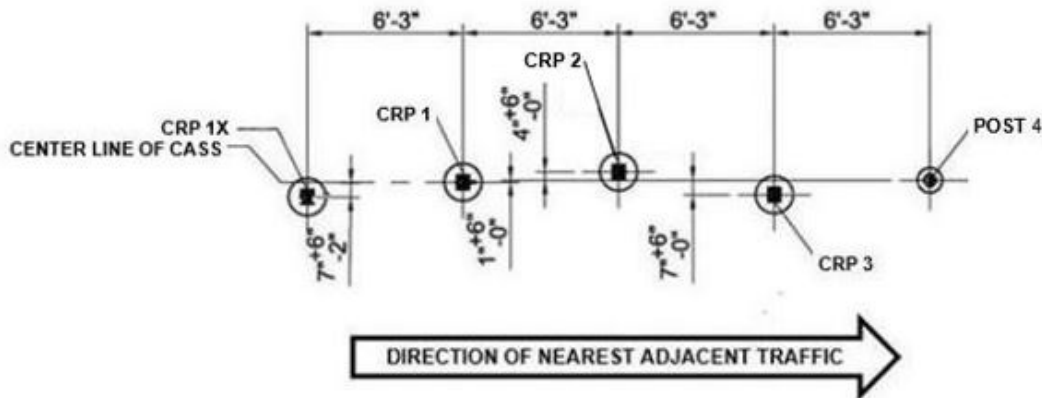

Figure 1b
CRP Offset 4 Cable system

Based on soil conditions at the site, the CCT may need larger/deeper concrete anchors or larger soil plates (for driven applications) as determined through soil-analysis.

Bottom CRP with Concrete Footings

Place the Bottom CRP (PN 33936A) in a minimum 18" [450] diameter x 5'-0" [1.50 m] deep reinforced MSC footing. The footing is reinforced with a spiral rebar cage.

Complete the following steps for the placement of the Bottom CRP in the concrete footing:

1. Lay out the three (3) or four (4) CRP footings.
2. Punch or auger the appropriate hole for the concrete footing.
3. Fabricate a rebar cage in accordance with project/shop drawing requirements. A standard spiral rebar cage that may be applicable is PN-33916B (See Figure 2).
4. Place the rebar cage in the footing hole, ensuring a minimum of 3" [75 mm] of concrete surrounds the cage on all sides and the cage is approximately 3" [75 mm] from the top of the footing (finished grade). Place the Bottom CRP in the center of the spiral rebar cage, ensuring the top of the post is no more than 4" [100 mm] above the finished grade. See Figure 3 for the orientation of the post.
5. Place the MSC in the hole. Consolidate the concrete to remove air pockets in compliance with applicable state specifications for similar applications.

6. Smooth off the top of the concrete footing with a slight crown from the sleeve.
7. Allow the footing to attain the required concrete strength before disturbing the foundations, including the placement of posts.

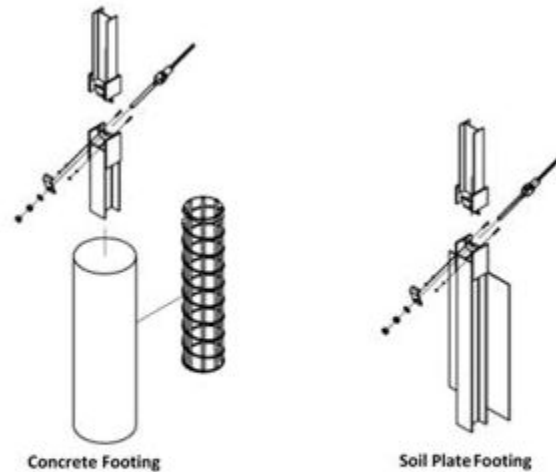

Figure 2
CRP Footing Details

Bottom CRP with Soil Plate

The Bottom CRP with Soil Plate assembly, size based on soil conditions, can be driven or placed in an augured hole. The soil plate can be either welded or bolted to the bottom CRP (See Figure 2).

Complete the following steps for assembling the CCT Bottom CRP with Soil Plate:

1. Lay out the three (3) footings.
2. Punch or auger a pilot hole approximately 4'-0" [1.92 m] or deeper for the Bottom CRP with soil plate if the post is not completely driven. Place the Bottom CRP with soil plate in the hole. The post is to be aligned with the soil plate on the downstream side of the post. Drive the post so that the top of the Bottom CRP does not protrude more than 4" [100 mm] above the finished grade.
3. Backfill the hole with material in 6" [150 mm] lifts and compact to optimum compaction.

CCT Line Footings

Post Alignment

Lay out the post alignment and post spacing. Starting at post 4 post spacing for posts 4 through 9 is 6'-6" [1.98 m]. The posts will be on the center line of the cable assembly.

Terminal Line Sleeve in a Poured Concrete Footing – Posts 4 through 9

Complete the following steps for placing a line terminal sleeve in a poured concrete footing:

1. Place the end cap (PN-5837B) on the bottom of the foundation sleeve (PN-33908G) to prevent the concrete from coming into the tube.

Note: These sleeves are different than the standard line post sleeves.

2. Punch or auger a minimum 12" [300 mm] diameter x 36" [0.91 m] deep hole for the concrete footing.
3. Pour the MSC in the hole with the top of the footing flush with the finished grade.
4. Place the foundation sleeve in the poured concrete footing. The sleeve is to be positioned plumb, flush with the top of the footing, ensure that the sleeve is aligned a minimum of 3" [75 mm] from the edge of the footing and the 3" [75 mm] side parallel to the roadway), Consolidate the concrete to remove air pockets in compliance with applicable state specifications for similar applications.
5. Place a re-bar ring (PN-5836B) around the top of the sleeve 2" to 3" [50 mm to 75 mm] from the top of the footing. Place two re-bars (PN-5919B) vertically as shown in Figure 3. If the specifying state/specifying agency requires a deeper footing, the length of the vertical re-bars will be the footing depth minus 4" [100 mm]. The two vertical re-bars do not have to be attached to the ring.
6. Smooth off the top of the footing.
7. Allow the footing to attain the required concrete strength before disturbing the foundations, including the placement of posts.

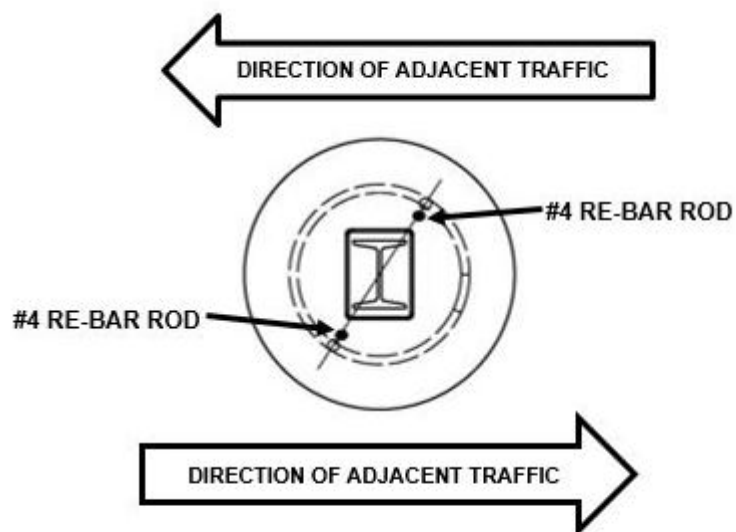

Figure 3
CCT Re-bar Placement

Terminal Line Precast Concrete Footings – Posts 4 to 9

The precast concrete footings will be fabricated in forms and installed the same as if placed in an augured hole. The precast footing will be placed in a punched or augured hole.

Terminal Line Driven Foundation Sleeve with a Soil Plate-Posts 4 to 9

Complete the following steps for placement of a driven foundation sleeve with a soil plate.

1. Drive the foundation sleeve with soil plate (PN-33952A) with an appropriate driving head. Ensure that the driving head keeps the sleeve orientated in the proper alignment and prevents soil from coming up into the sleeve while the post is being placed.

CCT Posts Assembly

Terminal Posts

The CCT consists of three (3) or four (4) CRPs and six (6) S3 x 5.7# [S75 x 8.5] terminal line posts (positioned in a sleeve or a driven post).

Cable Release Post (CRP) – Post 1 to Post 3 or Post 1X to Post 3

Complete the following steps for the placement of the CRP.

1. Place the top CRP (PN-33935A) on the assembled bottom CRP.
2. Place PN-4211G bolt in the two holes of the sloping plates of the top and bottom CRP.
3. Place a PN-3240G and PN-3245G on each of the bolts.
4. Tighten the nuts to a snug position with a minimum of two (2) bolt threads protruding beyond the nut.

Terminal Line Posts in Sleeve (Concrete Footing) – Posts 4 to 9

Complete the following steps for the placement of the terminal line posts in the sleeve:

1. Place the post sleeve cover (PN-5839B) on the bottom end of the terminal line posts (PN-33910G and PN-33955G).
2. Place post (PN-33910G) in sleeves 4 to 7 and post (PN-33955G) in sleeves 8 and 9. The cover will be located at the top of the sleeve.

Terminal Line Posts in Driven Sleeve-Posts 4 to 9

1. Complete the following steps for the placement of the terminal line posts in the driven sleeve: Place the post sleeve cover (PN-5839B) on the bottom end of the terminal line posts (PN-33910G and PN-33955G).
2. Place post (PN-33910G) in sleeves 4 to 7 and post (PN-33955G) in sleeves 8 and 9. The cover will be located at the top of the sleeve
3. Place a bearing angle (PN-9021G) on each side of the post 4 at the ground line (See Figure 4).
4. Place two (2) hex bolts (PN-4779G) and flat washers (PN-3701G) through the two (2) bearing angles. Place a hex nut (PN-3711G) and flat washer (PN-3701G) on the bolt. Tighten the nuts to a snug position with a minimum of two (2) bolt threads protruding beyond the nut.

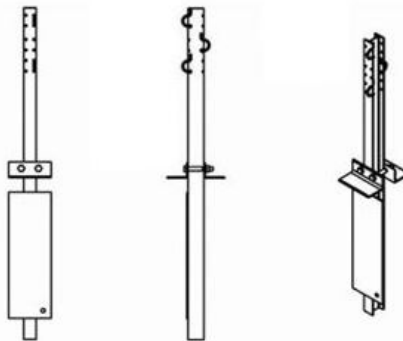

Figure 4
Bearing Angles

Terminal Line Driven Post with Soil Plate – Posts 4 to 9

Complete the following steps for the placement of a driven post with a soil plate:

1. Drive post (PN-33903A) at post locations 4 through 7 and post (PN-33989G) at post locations 8 and 9 with an appropriate driving head/equipment.
2. Follow Steps 3 and 4 in the “Terminal Line Posts in Driven Sleeve-Posts 4 through 9” section above.

Terminal Cables

The cables used in the CCT are pre-stretched, consisting of three (3) or four (4) precut cables with factory applied fittings (Option A) on each end; or cables can be field cut (Option B) taken from cable reels. The precut cable lengths are 41'-9" [12.73 m] (CRP 3), 48'-0" [14.63 m] (CRP 2), 54'-3" [16.54 m] (CRP 1) and 60'-6" [18.44 m] (CRP 1X). The field cut lengths can be the same as for precut, or can be of greater lengths, depending on specification and shop drawing provided for the cable run.

Complete the following steps for placing the CCT cables:

Installing the Cables to the CR posts:

Option A (Precut Cables)

- A. For the three (3) cable system, lay out the three (3) precut cables. The right threaded end of the cables will be attached to the CRP. The CRP 1 cable (PN-5817G) starts at CRP 1 (post location 1) and is placed on the front side (traffic side) of the line terminal posts; the CRP 2 cable (PN-5818G) starts at CRP 2 (post location 2) and is placed on the back side (away from traffic) of the line terminal posts; and the CRP 3 cable (PN-5819G) starts at CRP 3 (post location 3) and is placed on the front side (traffic side) of the line terminal posts.
- B. For the four (4) cable system, the CRP 1X cable is on the front side (traffic side) of the line terminal posts. The remaining cables will be placed the same as for a three (3) cable system.
- C. Place the right threaded end of the fitting through the hole formed by the top and bottom CRP.
- D. Place the CRP Cable Bracket (PN-33909G) on the threaded end. The angle end of the bracket is placed up (See Figure 3).
- E. Place a flat washer (PN-4903G) and hex nut (PN-4902G) on the threaded fitting on the cable. Thread the nut approximately halfway on to it. Place on the fitting a second hex nut up against the first nut
- F. Perform Steps B-D for the other two (2) cables or three (3) cables.

Option B (Field Cut Cables)

- A. Cut three (3) or four (4) lengths of cable from the cable reel (41'-9", 48'-0", 54'-3", and if required, 60'-6").
- B. Place a right-hand and left-hand field fitting (use the same size fittings used for line cables) on the end of the cables. See the Field Splice section for assembling the fittings.
- C. Perform Steps A-D in Option A **except** for Step D if using 3/4" fittings, then replace PN-4903G with PN-3701G and PN-4902G with PN-4959G.

Installing the Cables on the terminal posts:

1. The CRP 1 cable attached to CRP 1 will use the top two holes on line terminal posts 4 through 9.
2. The CRP 2 cable attached to CRP 2 will use the middle two holes on line terminal post 9; holes 4 and 5 on line terminal post 8; and the bottom two holes for posts 4-7.
3. The CRP 3 cable attached to CRP 3 will use the bottom two holes on line terminal posts 4 through 9.
4. The CRP 1X cable attached to CRP 1X will use holes 4 and 5 on line terminal posts 4 through 9.
5. The cables are attached to the posts using cable lock bolts (PN-5925G) (See Figure 5).
6. Insert the non-threaded end of the bolt in one of the two required holes and place the bolt around the cable and insert the threaded end in the other required hole (**either orientation of the cable lock bolt is acceptable**). Place a hex nut (PN-3245G) on the bolt, and tighten until snug with a minimum of two threads beyond the nut.



Figure 5
Placement of the Cable Lock Bolt

Line Cables

The cables used in CASS® S4(38) are pre-stretched. They are supplied on reels, either precut with factory applied fittings (in 1,000' [305 m] increments) or continuous length to be cut in the field and field applied fittings attached. The reels can be supplied with 2,000' to 3,000' [610 m to 914 m] of cable on each reel. The precut cable has a right-hand fitting on one end and left-hand fitting on the other end. The cables are placed on the reel with the left-hand fitting placed on the reel first. The right-hand fitting end for the cable must come off first and the end is painted red for identification. When there is more than one cable on the reel, the last cable placed on the reel will have the right-hand fitting painted red and also a yellow mark. This will be the first cable removed from the reel.

Lengths less than 1,000' [305 m] can be supplied with a factory applied fitting (right-hand fitting) on one end, or the lengths can be cut from a continuous reel and a field applied fittings placed on both ends.

Cable Splices

There are three types of cable splices that can be utilized.

- Factory applied fittings with a turnbuckle (1" hardware only).
- Field applied fittings with a turnbuckle (3/4" and 1" hardware).
- Torpedo fitting.

Factory Applied Fittings with Turnbuckle

1. To assemble a factory applied splice, one of the two cable ends must have a fitting with right-handed threads and the other cable must have a fitting with left-handed threads. Place a mark 1-1/2" [38 mm] from the end of each fitting. On one of the threaded ends place a turnbuckle (PN-5826). Attach the turnbuckle where it is held on the threaded end by only a couple of threads.
2. Place the other threaded end in the turnbuckle.
3. While rotating the turnbuckle, prevent the two threaded ends from rotating. Rotate the turnbuckle until both threaded ends are into the turnbuckle beyond the 1-1/2" [38 mm] mark. See Figure 6 for the complete assembly.



Figure 6
1" Cable Splice with Turnbuckle

Field Applied Fittings with Turnbuckle

There are two situations where a field applied fitting will be used: either when a fitting is required to complete an assembly; or when no factory applied fittings are used and field applied fittings are needed to make all of the cable connections. See Figure 6a for a 1" Cable Splice (PN-5633G) and Figure 6b for 3/4" Cable Splice (PN-5698G).



Figure 6a
1" Cable Splice with Turnbuckle



Figure 6b
3/4" Cable Splice with Turnbuckle

Perform the following steps to complete a splice using a field applied fitting and a turnbuckle:

1. Ensure that the cable has a clean square cut by using a saw with an abrasive blade or an electric band saw.
2. Insert the cut end of the cable into the field casting (PN-4190G) through the triangular end.
3. With the cable inside the casting, separate the cable with two flathead screwdrivers for insertion of the tapered triangular wedge (PN-4199B) between the three strands of cable.
4. Insert the wedge into the cable with the smaller diameter end towards the triangular hole. Ensure that the wedge is pushed 1/2" [13 mm] beyond the end of the cable (plus or minus 1/8" [3 mm]).

Note: All three bundles of the cable are to be located in the appropriate grooves of the wedge

5. Once the wedge is inserted, use a hammer and drift pin or other appropriate tool to seat the wedge by hitting on the triangular end of the housing. Several hits should be made to seat the wedge.
6. A heavy hex nut (PN-3908G for 1" fitting) or heavy square nut (PN-4959G for 3/4" fitting) has to fit inside the housing. Once the wedge has been seated, check to make sure the nut will fit. If it will not, reseal the wedge.
7. After the wedge is properly seated, one (1) wire of the cable must be bent over the end of the wedge.
8. Insert the appropriate hex nut in the housing.
9. Place the left-hand threaded stud (PN-3537G for 1" fitting or PN-105204G for 3/4" fitting) or right-hand threaded stud (PN-3536G for 1" fitting or PN-105205G for 3/4" fitting) in the housing and into the nut. Screw the stud into the nut until it will not go any further. A minimum of two threads of the stud must show beyond the nut.
10. With the field applied fitting attached, follow the steps for a "Factory Applied Fitting" section to connect the two cables with a turnbuckle.

Torpedo Cable Splice

When two cable ends are spliced together other than where spliced with a turnbuckle, a Torpedo Cable Splice can be used. The Torpedo Cable Splice (PN-4099G) assembly is made up of two (2) housings, one of which has threads on it, a threaded ring, and two triangular wedges. (See Figure 7).



Warning: The distance from the torpedo splice to any other fitting must be 100' [30 m] or greater.

Perform the following steps to complete a splice:

1. Ensure that the cables have a clean square cut by using a saw with an abrasive blade or an electric band saw.
2. Insert the cut end of the cable through the triangular end of the threaded Torpedo fitting.
3. Separate one (1) of the wires from the others by bending it out of the way.
4. Cut the remaining twenty (20) of the twenty-one (21) wires off about 1/2" to 3/4" (13 mm to 19 mm) from the end of the cable. Care should be taken to not nick the separated wire.

5. With the wires cut off, separate the cable with two flathead screwdrivers and insert the tapered triangular wedge (PN-4199B).
6. With the wedge inserted into the cable, drive the wedge into the housing until the twenty (20) wire strands are flush with the end of the housing. Bend the one (1) extended wire of the cable over the end of the wedge.
7. On the other cable, place the threaded ring on it so the threads inside the ring are towards the end of the cable.
8. On this same cable, follow Steps 1-7 to assemble the cable in the fitting.
9. Place the two (2) Torpedo Cable pieces together and connect them with the threaded ring. Tighten the connection with a pipe wrench(s), ensuring no more than two threads are shown after the connection.

Note: No more than two threads should be shown after the connection.

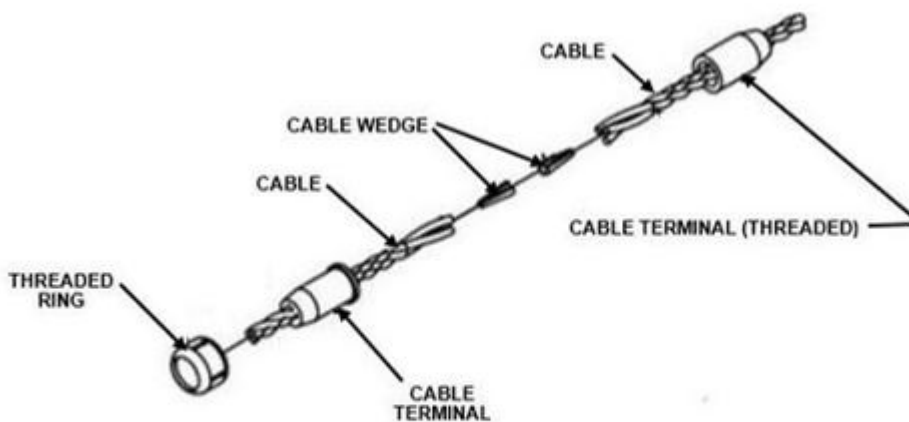

Figure 7
Torpedo Cable Splice

Laying Out the Cable / Attaching the Cables to the Posts

The cable can be either precut lengths or length from a cable reel. The method of laying out the cable will be determined by the contractor. The cables can be laid out one (1) cable at a time or multiple at the same time. The Valtir Shop Drawings supplied for the project is used to determine what cables need to be used where.

Complete the following steps for laying out the cables and attaching them to the posts:

1. Using the Valtir Shop Drawings for the cable run to select the cables needed to complete the assembly.
2. Attach the right-hand threaded end of the cable to the terminal or Anchor cables. Use the factory applied fitting with a turnbuckle method or field-applied fittings with a turnbuckle to make the connection. Ensure that the top, middle and bottom cables are identified.

For the three (3) Cable system:

1. Place the bottom cable in the bottom of the post slot. Place a black spacer (PN-5703B) or reflective spacer (PN-5705B yellow or PN-5706B white) on top of the cable (See Figure 8). The use of the reflective spacers will be per the contract plans.

- Place the middle cable on top of the spacer and place a post strap (PN-5824T) and spacer on the post on top of the middle cable (See Figure 9). Use the same color spacer that was placed on top of the bottom cable.
- Place the top cable on top of the spacer (See Figure 10).



Figure 8
1st Cable Installed

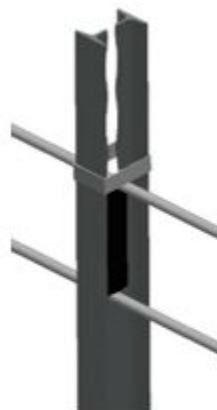

Figure 9
2nd Cable Installed



Figure 10
3rd Cable Installed

For the four (4) cable system:

- Place the CRP 3 cable in the bottom of the post slot. Place a black spacer (PN-5700B) or reflective spacer (PN-5701B yellow or PN-5702B white) on top of the cable (See Figure 11). The use of the reflective spacers will be per the contract plans.
- Place the CRP 1X cable on top of the spacer. On top of the cable, place the same spacer that was placed on top of the bottom cable (See Figure 12).
- Place CRP 2 cable on top of the spacer and place a post strap (PN-5824T) on the post on top of the CRP 2 cable (See Figure 13). On top of the CRP 2 cable place a 8" black spacer (PN-5703B) or reflective spacer (PN-5720B yellow or PN-5706B white). Use the same color spacer that was placed on top of the cables below.
- Place the CRP 1 cable on top of the spacer (See Figure 14).



Figure 11
1st Cable Installed



Figure 12
2nd Cable Installed



Figure 13
3rd Cable Installed



Figure 14
4th Cable Installed

It is recommended before tensioning, that for runs of cable greater than 5,000' [1,525 m], to pull the cable at intervals of 3,000' [915 m] to remove excess slack. Check to make sure no turnbuckles or torpedo splices will interfere with the posts during the tensioning. If there are any, remove the post(s) or the cables from the post.



Important: For long runs of cable, check the turnbuckles at every location to ensure the cable has not unthreaded during the laying out or slack pulling process. Ensure the threaded rod can be seen through the holes on each end of the turnbuckle and the 1-1/2" [38 mm] mark cannot be seen..

Tensioning and Tension Meter

After all of the cables have been placed in the posts, tensioning can take place. The tension placed on the cables is to be determined by the cable temperature at the time of tensioning. The tension meter shall be set for pre-stretched cable. An infrared thermometer is to be on-site at the point of tensioning to obtain the correct cable temperature. If an infrared thermometer is not available, obtain the air temperature from a reliable source in the immediate area and not influenced by other factors. See the CASS® S4(38) Temperature and Tension Chart for the tension requirements at the back of this manual.

Note: Due to frictional forces, it is recommended to start tensioning from the bottom cable, working upwards to the top cable.

The means of placing tension on the cable will be determined by the contractor. Whatever means is chosen, it must ensure that the tension from the tension chart can be obtained.



Important: Completely review the manufacturer's manual included with the tensioning meter prior to tensioning of the cable.



Important: Ensure that the tension meter is set for pre-stretched cable.



Important: Completely review the infrared thermometer manufacturer's manual prior to tensioning of the cable.



Warning: Infrared light is harmful if shined into the eyes.



Warning: Read and understand the directions provided for the CASS® Cable pulling tool.



Warning: Extreme care should be taken to ensure that the CASS® cable pulling tool is attached to the cable in such a location that if it slips, the chain or pulling tool will not hit anyone. It is suggested that the pulling equipment be placed between the workers and the CASS® cable pulling tool. Read the directions and make sure the tool is clean, dry and not worn.

Complete the following steps to tension the cables:

1. Check the cable run to see if any of the turnbuckles or torpedo cable splice will pass from one side of the post to the other during the tensioning process. If they will, pull the post for the tensioning process. Also check the fitting marks at each turnbuckle to make sure no marks are showing.
2. The tensioning of the cable will be taken at a location no closer than 500' [167 m] from the end that has not been connected to the CCT or Anchor Cables.
3. For cable runs greater than 5,000' [1,525 m], it is recommended that the cable be pulled every 3,000' [915 m] to remove the slack from the cable.
4. With the required tension on the cable, place a mark on the cable where it meets the threaded end of the CCT.
5. Release the tension on the cable. Go back approximately 28" [0.71 m] from the mark and cut the cable.
6. Place a right-hand field applied fitting using the procedures in the Field Applied Fittings with a Turnbuckle section.
7. On the CCT end, place a turnbuckle (PN-5826G) on the fitting by only a couple of threads. Pull the cable until the cables are connected to the turnbuckle. With both fittings inserted in the turnbuckle, the turnbuckle will be turned until the 1-1/2" [38 mm] marks on the cables ends of both threaded rods are in the turnbuckle and threaded rods can be seen in the site hole.
8. With the cables connected, release the CASS® cable pulling tool from the cable. Check the tension on the cable. If a higher tension is needed, rotate the turnbuckle while the cables are restrained to prevent twisting.
9. Replace any posts removed during the tensioning process. If a turnbuckle or torpedo cable splice falls where there is a post, or if the turnbuckle or torpedo cable splice is 1' [300 mm] from the post, replace the post with a straight cut notch post (PN-33974G).
10. Two (2) or three (3) days after tensioning, check and record the tension values, at the same locations as taken in step 2. If adjustment is needed to meet the tension on the tension chart, the turnbuckles can be adjusted. After adjustment, ensure the threaded rod is no more than 4" [100 mm] into the turnbuckle. It is suggested that the tension recorded be set approximately 800 lbf. [3.6 kN] above the value on the tension chart.
11. **It is recommended that approximately two (2) to three (3) weeks after the cable tensioning in Step 10, the cable tension is checked again against the tension chart. Make any adjustments necessary to meet the appropriate tension.**

Delineation

The specifying state/specifying agency will establish the criteria for delineation of the line posts. The delineation is typically provided on the spacer used to separate the cables.

It is suggested for the terminal CRP that reflective sheeting (PN- 5851 or PN-5851) be affixed to delineate them, which could help to reduce some impacts. Valtir makes no guarantees they meet the minimum specifications, comply with MUTCD requirements or comply with state/specifying agency requirements. It is recommended that all of the CRPs be delineated.

Repairs

After an impact, the system will require repair. Full scale crash testing conducted in conformance with NCHRP Report 350 indicates that the cable will typically remain close to its original height depending on the number of posts damaged. It is recommended that the system be repaired as soon as possible by the state/specifying agency.

After most impacts, the system can be repaired in a relatively short period of time. Any part(s) which visually appears damaged must be replaced. Additional specific parts of CASS® S4(38), which must be replaced in order to bring the system back into full service, is a decision that must be made by the state or specifying state/specifying agency.

An impact that encounters a CCT may require re-tensioning of the entire run of cable. After repairing the cable, the tension throughout the system should be checked.

It is recommended that for impacts outside of the testing parameters that the cable be checked to determine if re-tensioning is required.



Important: Valtir makes no recommendation whether use or reuse of any part of the system is appropriate or acceptable following an impact. It is the sole responsibility of the state/specifying agency and its engineers or its agent to make that determination. It is critical that you inspect this product after assembly is complete to make certain that the instructions provided in this manual have been strictly followed.

Repair for CASS® S4(38) Impact (CRP Not Impacted)

If an impact occurs and a CCT CRP is not involved, usually only the line or terminal posts will have to be replaced and the cables re-inserted in the posts or attached to the post. Follow the steps below in making this repair:

1. Inspect the damaged system and determine what components will be required to correct and repair CASS® S4(38) to originally specified working condition.
2. Remove the damaged posts. During very cold weather and in Northern climates, the post may become frozen into the socket. Successful means of extraction have utilized propane torches or a hammer drill to break-up the ice. With approval from the State specifying highway state/specifying agency, calcium chloride (a common deicing chemical) can also be mounded over the top of the ice for 24 hours prior to removal of the post. As always, wear appropriate safety equipment such as work gloves and eye protection during post removal. If the posts are driven, they will have to be pulled out of the ground.
3. Replace any damaged posts.
4. Replace the cables. For the line cables, see the “**Laying Out the Cable/Attaching the Cables to the Post**” section. For the CCT cables, see the “**Terminal Cables**” section.

Depending on the severity of the impact, after the repair, the cable may need to be re-tensioned. Valtir recommends the tension of the cable be checked with the tension meter and adjustments made at the turnbuckles to bring the cable to the correct tension based on the cable temperature values on the CASS® S4(38) System Temperature/Tension chart. See the “**Tensioning and Tension Meter**” section to make any tension adjustments.

Note: The reflective sheeting may be placed on the spacer for CASS® S4(38) based on the state/specifying agency’s specification.

Repair for CASS® S4(38) Impact (CRP Involved)

When the system has been impacted and CRP is involved, follow the steps below:

1. Inspect the damaged system and determine what material will be required to make the repairs.
2. For the CRPs that have been impacted, inspect the top and bottom post for damage. Repair and replace any damaged posts. See the “**CCT Post Assembly**” section. For any other posts that have been damaged, follow the criteria in the “**Repair for CASS® S4(38) Impact (CRP Not Impacted)**” section.
3. Attach any detached cables and re-tension the cable.

Emergency Repairs

There is a possibility that an accident could cause significant traffic congestion, or the cable can be entangled with the vehicle. When a vehicle is entangled in the cable, the first step that must be undertaken is to move or drive the vehicle as close to the centerline of the cable system as a feasible, in order to reduce tension. The following suggestions may help to get traffic moving and the cable untangled:

Road Blocked Due to an Accident

To resume traffic flow after an accident or to get emergency vehicles access to the accident site, crossover access through the cable may be necessary. To provide this access, remove cables from several posts upstream and downstream of the desired opening. The opening width can be adjusted by removing posts from the ground sleeves. The cable can be held down and the traffic or emergency vehicles can pass over it.

PPE equipment such as protective gloves, safety goggles, and mask must always be used. **Keep personnel out of the area upstream and/or downstream from the point of the cut.**

In life threatening or emergency situations the cable can be cut.

If the cable was put under additional tension due to the accident, the tension can be reduced at the turnbuckles closest to the impact. The turnbuckle can be backed off; however, **it is critical that the fittings remain engaged within the turnbuckle a minimum of 3/4” [19mm] when the cable is under tension.**

To reduce the amount of the cable damage during cutting and limit fraying, tape must be wrapped around the cable and the cut made through the tape. **Some agencies have also cut through the turnbuckle itself.** This may help to reduce the maintenance/repair effort. When cutting through a turnbuckle, ensure that all posts, both upstream and downstream for a distance of 50'-0” [15 m], are removed in order to prevent turnbuckle or fitting interference.

If time permits, the tension can be released by pushing over one or more of the CRP(s) with a piece of equipment.

Removing Entangled Cable from a Vehicle

When the cable is entangled with a vehicle that must be towed away, remove the entangled cable by lifting one or more of the cables up over the vehicle. During this operation, if any of the line posts entangled with the cable start to lift up out of the sleeves, the lifting must be stopped and the posts removed from the cable. Once the posts are removed, the cable can be lifted up over the vehicle.

In addition, if the entangled vehicle is located near the CCT end, it is possible to reduce tension by loosening the two large nuts on the terminal cable end. **DO NOT COMPLETELY REMOVE EITHER OF THE NUTS!**

Repairing a Cut or Damaged Cable

Following are various methods to repair cables that have been cut or damaged:

Method 1 – Splicing the Cable

Splicing the cable may be necessary if a cable is cut or damaged during an impact. The length of the cable must be 50'-0" [15 m] or longer to make the splice.

1. Re-cut the ends of the cable to ensure the ends are clean and smooth.
2. Refer to the “**Cable Splices**” Section when making a cable splice connection.
3. If an accurate length of cable is used for the splice section, two cable splice connectors will be required to connect the cables together.
4. Connect one end of the splice cable to one end of the cut cable with a connector.
5. Apply another connector to the other end of the splice cable and the end of the cut cable.
6. Assemble the cable splice connector using a backhoe or other mechanical means.
7. Check the tension on the cable with the tension meter and adjust the turnbuckles to bring the cable to the correct tension based on the infrared thermometer cable temperature reading and the values on CASS® S4(38) Temperature/Tension Chart.

Note: If the cable splice has been cut accurately, the tension may be obtained by turning the turnbuckles at each side of the cut.

If the tension cannot be obtained at the turnbuckles at each side of the splice, it may be necessary to follow the procedures in the “**Tension and Tension Meter**” Section. Some assemblies may have field splices at all locations. If this is the case, the measuring, cutting, and re-connecting can be done at any location.

Method 2 – 5'-0" [1.5 m] Section (Factory Applied Fittings)

A second method to reconnect the cables is to use a 5'-0" [1.5 m] Cable Field Repair Section (PN-5840G) of cable with a factory applied fitting on each end. This method will also require two turnbuckles and a left-hand and right-hand threaded fitting to complete the connection.

1. Remove approximately 9'-8" [2.9 m] of cable from the damaged cable.
2. Connect the threaded fittings and the cable ends connections per the “**Factory Applied Fittings with Turnbuckle**” Section.

Method 3 – Other Than 5'-0" [1.5 m] Cable (Factory or Field Applied Fittings)

When using a cable length other than 5'-0" [1.5 m], the amount of cable removed from the damaged cable is to be adjusted based on the cable length removed.

1. To determine the amount of cable to be removed, after the threaded fittings are placed on the piece of splice cable, take a measurement from end-of-fitting to end-of fitting. Take this measurement and add 4'-6" [1.3 m] and this will be the amount of cable to be removed from the damaged cable.
2. If the length of cable used is less than 5'-0" [1.5 m], remove less than 9'-8" [2.9 m] of cable from the damaged cable.
3. If more than 5'-0" [1.5 m] of cable is used, remove more than 9'-8" [2.9 m] of cable from the damaged cable.

Method 4 – Using Field Applied Fitting Connections Only (No Cables)

If the damaged cable, after cutting, is less than a total of 4'-6" [1.3 m], the connection can be made with a left and right threaded field applied fittings and a turnbuckle.

1. Remove 4'-6" [1.3 m] of cable from the cable run.
2. Place a left-hand threaded fitting on one end of the cut cable and right-hand threaded fitting on the other end of the cut cable.
3. Follow the procedures in the "**Field Applied Fittings with Turnbuckle**" Section.

After completing one (1) of the four (4) methods above, check the tension on the cable with the tension meter and adjust the turnbuckles to bring the cable to the correct tension based on the cable temperature and the values on CASS® S4(38) Temperature/Tension Chart.

Cable Tension Inspection Program

Valtir recommends the cable tension be checked at least once a year. The tension value is established based on the cable temperature, which can be taken using an IR thermometer for the cable temperature. If an infrared thermometer is not available, obtain the air temperature from a reliable source in the immediate area and not influenced by other factors. See CASS® S4(38) Temperature/Tension Chart for the tension values.

CASS® S4(38) Assembly/Repair Checklist **(File With Project/Maintenance Records)**

Performed by: _____

Date: _____

Location: _____

- 1. Ensure only Valtir CASS® S4(38) parts are used for the assembly/repair of CASS® and that all parts are free of damage. (p 4)
- 2. Ensure required traffic control is in place to conduct CASS® S4(38) assembly/repair. (p 4)
- 3. Ensure proper site grading for the CCT complies with state/specifying agency guidelines for guardrail terminals or AASHTO Roadside Design Guide, whichever is more stringent. (pp 5 & 15)
- 4. Ensure proper site grading for CASS® S4(38) complies with state/specifying agency guidelines or AASHTO Roadside Design Guide. (pp 5 & 15)
- 5. Ensure the Sleeve Cover is paced on the post and is flush with the top of the Post Sleeve. (pp 18 & 22)
- 6. Ensure the Bottom CRP and Top CRP are oriented correctly. (pp 18 & 19)
- 7. Ensure the top of the Bottom CRP's does not protrude more than 4" [100 mm] above the finished grade. (p 18)
- 8. Ensure the bent part of the Cable Anchor Bracket at the CRP's is up and hooked over the Top CRP's. (p 23)
- 9. Ensure two (2) 1" Hex Nuts have been placed on the ends of the cable fittings at the CRP's. (p 23)
- 10. Ensure the cables are located and assembled at the proper holes of the Terminal Line Posts with the Cable Lock Bolts. (p 23 & 24)
- 11. Ensure that the Field Applied Fittings have a single cable strand bent over the wedge. (p 26)
- 12. Ensure Cable Spacers are placed between the cables. (p 28)
- 13. Ensure the CASS® S4(38) delineators are placed per the contract plans. (p28)
- 14. Ensure the Stainless Steel Post Strap is placed below the top cable. (p 28)
- 15. Ensure the Fittings are a minimum of 1-1/2" [38 mm], maximum of 4" [100 mm] into the turnbuckle. (p 28)
- 16. Ensure the Tension on the cable has been checked and is as specified in "CASS® S4(38) Temperature/Tension Chart". (p 29)
- 17. Ensure there are no damaged/frayed/bent cables. (p 29)
- 18. Ensure delineation is placed on CASS® CRP's and line post per MUTCD and/or state/specifying agency.
(p 30)

CASS® S4(38) Routine Inspection Checklist

(File with Maintenance Records)

Performed by: _____

Date: _____

Location: _____

Valtir recommends the state/specifying agency develop and administer their own end terminal inspection program, based on location of unit, volume of traffic and impact history.



Important: CASS® S4(38) and all of its components shall be inspected for damage after every impact. **Repair using only Valtir parts that are specified for use within the CASS® S4(38) CAble Safety System Product Description Assembly Manual, latest edition.**

If no CASS® S4(38) or Cable Barrier inspection program exists, Valtir recommends visual drive-by inspections at least once every month and walk-up inspections every one (1) year. These inspections shall, at a minimum, consist of:

Visual Drive-By Inspections (Recommended Frequency: Monthly)

- Check for damage caused by vehicle impacts.
- Check for damage caused by impacts from snowplow, mowing or roadway operations.
- Check for misalignment.
- Check for missing system components.
- Check for vandalism.
- Check for damage caused by adverse weather conditions (i.e. erosion, weight of snow, UV).

Walk-Up Inspections (Recommended Frequency: Yearly)

Walk-Up Inspections include ALL Visual Drive-By Inspection items (listed above) as well as the items listed below.

- Ensure required traffic control is in place to conduct walk-up inspection.
- Check and record the tension per the manufacturer's recommendation.
- Clear and dispose of any debris or trash found on the CASS® S4(38) or interfere with the performance of CASS® S4(38).
- Check for erosion to the site grading around the system or any CRP movement.
- Check all fasteners to ensure they are tight.

If any of the above items are identified during the inspection process as being deficient, swift action shall be taken to correct and repair the CASS® S4(38) to working condition as outlined in the **CASS® S4 38" High CAble Safety System** Product Description Assembly Manual, latest edition.

CASS® S4(38) Temperature / Tension Chart

Pre-Stretched Cable			
°F	Tension (lbf)*	°C	kN
-15	7500	-26	33.3
-10	7300	-23	32.5
-5	7100	-21	31.6
0	7000	-18	31.1
5	6800	-15	30.3
10	6600	-12	29.4
15	6500	-9	28.9
20	6300	-7	28.0
25	6100	-4	27.1
30	6000	-1	26.7
35	5800	2	25.8
40	5600	4	24.9
45	5500	7	24.4
50	5300	10	23.6
55	5100	13	22.7
60	5000	16	22.2
65	4800	18	21.4
70	4600	21	20.5
75	4500	24	20.0
80	4300	27	19.1
85	4100	29	18.2
90	4000	32	17.8
95	3800	35	16.9
100	3600	38	16.0
105	3500	41	15.6
110	3300	43	14.7
115	3100	46	13.8
120	3000	49	13.3
125	2800	52	12.5
130	2700	54	12
135	2600	57	11.6
140	2500	60	11.1
145	2400	63	10.7
150	2300	65	10.2
160	2100	71	9.3
170	1900	77	8.5
180	1700	82	7.6
190	1500	88	6.7
200	1300	93	5.8

* Tolerance: -200 to + 800 pounds force [-0.9 to + 3.6 kN]

3 Cable Tension Log Cable Safety System™

Project Owner: _____
 Project Number: _____ Project Description: _____
 CASS™ Version: _____ Valtir Drawing #: _____
 Date Checked: _____ By: _____ Company/State/specifying agency: _____
 IR Temperature of Steel: _____ Corresponding Chart Lbf. Tension: _____

ALWAYS check tension in a tangential (NON-radii) section of the cable installation, a minimum of 500 LF from a terminal.

Run # _____ STA: _____ to STA: _____ LF of Run: _____

Loc: _____ Actual Lbf. ↓	Loc: _____ Actual Lbf. ↓	Loc: _____ Actual Lbf. ↓	Loc: _____ Actual Lbf. ↓
Top _____	Top _____	Top _____	Top _____
Middle _____	Middle _____	Middle _____	Middle _____
Bottom _____	Bottom _____	Bottom _____	Bottom _____

Loc: _____ Actual Lbf. ↓	Loc: _____ Actual Lbf. ↓	Loc: _____ Actual Lbf. ↓	Loc: _____ Actual Lbf. ↓
Top _____	Top _____	Top _____	Top _____
Middle _____	Middle _____	Middle _____	Middle _____
Bottom _____	Bottom _____	Bottom _____	Bottom _____

Loc: _____ Actual Lbf. ↓	Loc: _____ Actual Lbf. ↓	Loc: _____ Actual Lbf. ↓	Loc: _____ Actual Lbf. ↓
Top _____	Top _____	Top _____	Top _____
Middle _____	Middle _____	Middle _____	Middle _____
Bottom _____	Bottom _____	Bottom _____	Bottom _____

Loc: _____ Actual Lbf. ↓	Loc: _____ Actual Lbf. ↓	Loc: _____ Actual Lbf. ↓	Loc: _____ Actual Lbf. ↓
Top _____	Top _____	Top _____	Top _____
Middle _____	Middle _____	Middle _____	Middle _____
Bottom _____	Bottom _____	Bottom _____	Bottom _____

Loc: _____ Actual Lbf. ↓	Loc: _____ Actual Lbf. ↓	Loc: _____ Actual Lbf. ↓	Loc: _____ Actual Lbf. ↓
Top _____	Top _____	Top _____	Top _____
Middle _____	Middle _____	Middle _____	Middle _____
Bottom _____	Bottom _____	Bottom _____	Bottom _____

Loc: _____ Actual Lbf. ↓	Loc: _____ Actual Lbf. ↓	Loc: _____ Actual Lbf. ↓	Loc: _____ Actual Lbf. ↓
Top _____	Top _____	Top _____	Top _____
Middle _____	Middle _____	Middle _____	Middle _____
Bottom _____	Bottom _____	Bottom _____	Bottom _____

4 Cable Tension Log

Cable Safety System™

Project Owner: _____
Project Number: _____ **Project Description:** _____
CASS™ Version: _____ **Valtir Drawing #:** _____
Date Checked: _____ **By:** _____ **Company/State/specifying agency:** _____
IR Temperature of Steel: _____ **Corresponding Chart Lbf. Tension:** _____

ALWAYS check tension in a tangential (NON-radii) section of the cable installation, a minimum of 500 LF from a terminal.

Run # _____ **STA:** _____ **to STA:** _____ **LF of Run:** _____

Loc: _____ Actual Lbf. _____	↓	Loc: _____ Actual Lbf. _____	↓	Loc: _____ Actual Lbf. _____	↓
Top _____		Top _____		Top _____	
Low Top _____		Low Top _____		Low Top _____	
High Bottom _____		High Bottom _____		High Bottom _____	
Bottom _____		Bottom _____		Bottom _____	

Loc: _____ Actual Lbf. _____	↓	Loc: _____ Actual Lbf. _____	↓	Loc: _____ Actual Lbf. _____	↓
Top _____		Top _____		Top _____	
Low Top _____		Low Top _____		Low Top _____	
High Bottom _____		High Bottom _____		High Bottom _____	
Bottom _____		Bottom _____		Bottom _____	

Loc: _____ Actual Lbf. _____	↓	Loc: _____ Actual Lbf. _____	↓	Loc: _____ Actual Lbf. _____	↓
Top _____		Top _____		Top _____	
Low Top _____		Low Top _____		Low Top _____	
High Bottom _____		High Bottom _____		High Bottom _____	
Bottom _____		Bottom _____		Bottom _____	

Loc: _____ Actual Lbf. _____	↓	Loc: _____ Actual Lbf. _____	↓	Loc: _____ Actual Lbf. _____	↓
Top _____		Top _____		Top _____	
Low Top _____		Low Top _____		Low Top _____	
High Bottom _____		High Bottom _____		High Bottom _____	
Bottom _____		Bottom _____		Bottom _____	

Loc: _____ Actual Lbf. _____	↓	Loc: _____ Actual Lbf. _____	↓	Loc: _____ Actual Lbf. _____	↓
Top _____		Top _____		Top _____	
Low Top _____		Low Top _____		Low Top _____	
High Bottom _____		High Bottom _____		High Bottom _____	
Bottom _____		Bottom _____		Bottom _____	

Appendix A: Flare Assemblies 30:1 Flare

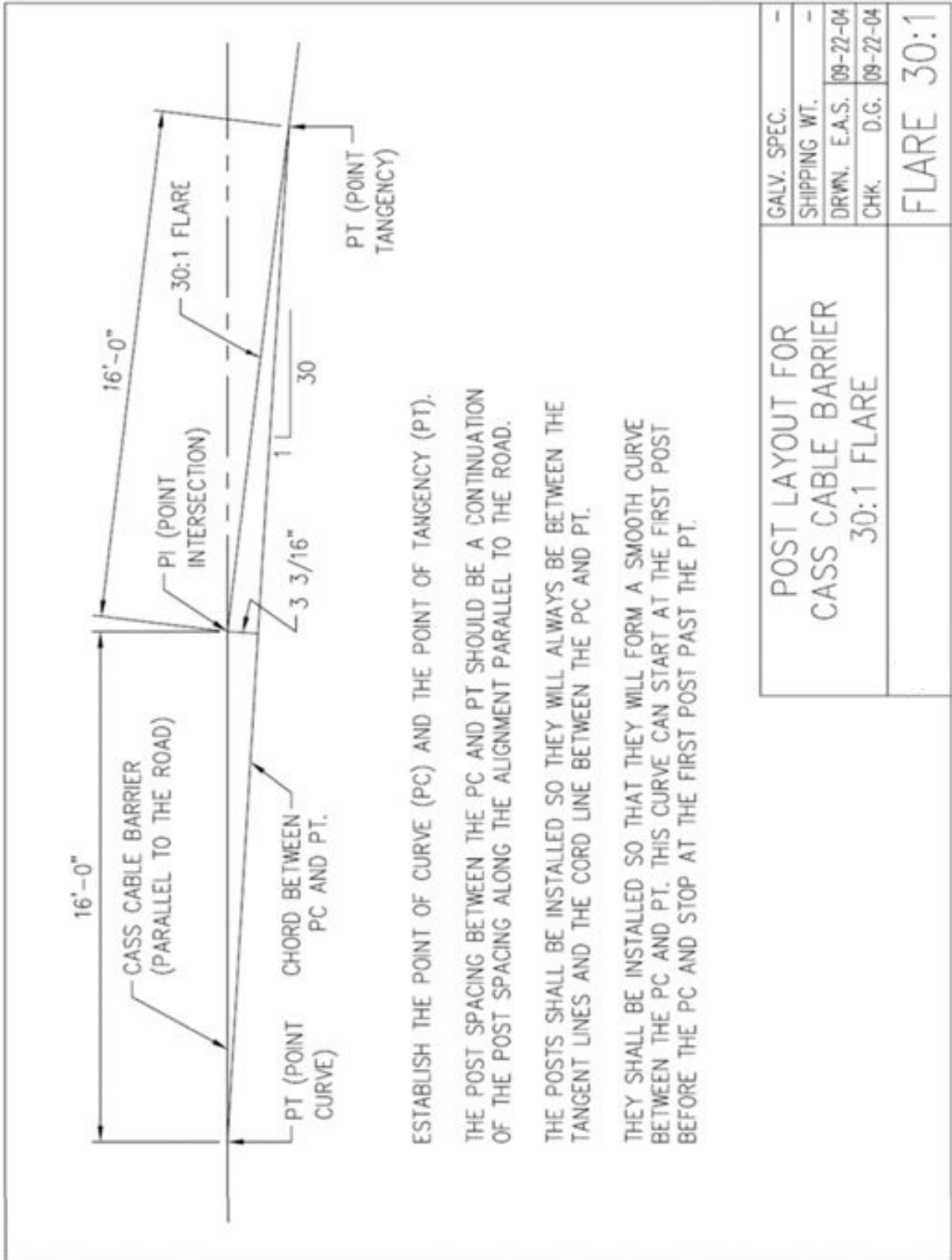

POST LAYOUT FOR CASS CABLE BARRIER 30:1 FLARE	GALV. SPEC.	-
	SHIPPING WT.	-
	DRWN. E.A.S.	09-22-04
	CHK. D.G.	09-22-04
		FLARE 30:1

Appendix B: Cable Barrier Overlap

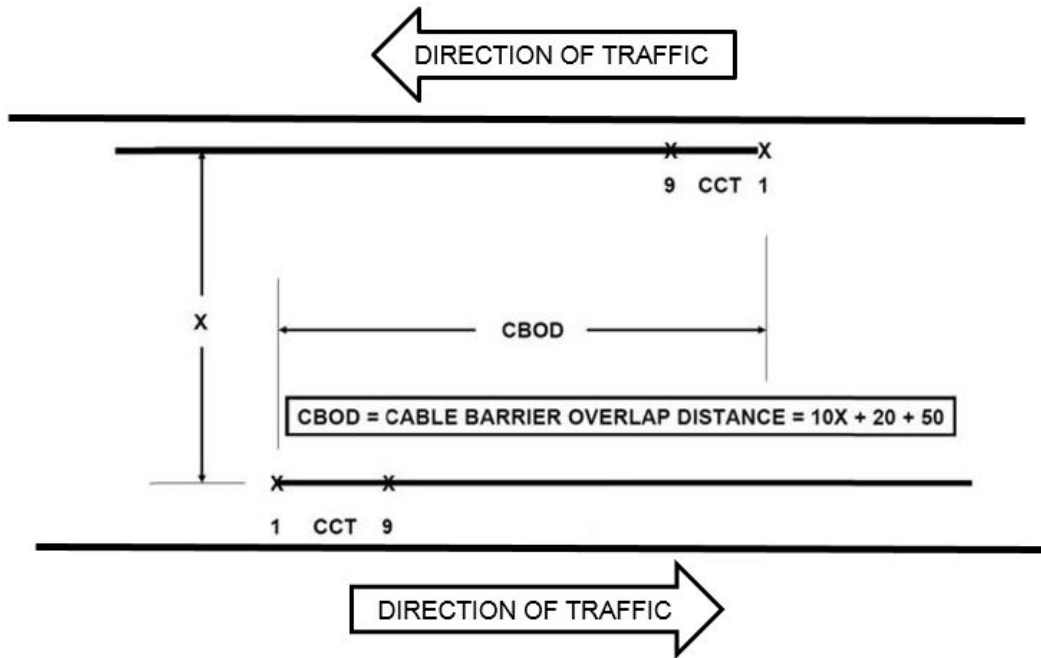

Use the cable barrier overlap distance calculated by the use of the CBOD formula. If the CBOD is greater than 370' {113 m}, use 370' {113 m}.

Cable Barrier Overlap Detail A

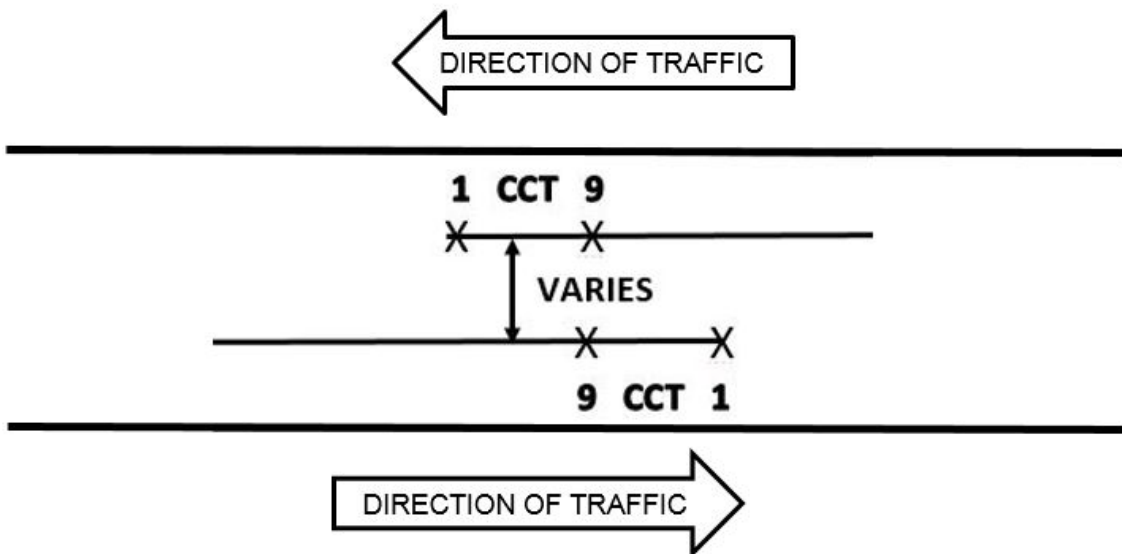

Cable Barrier Overlap Detail B

Appendix C: Encountering Rock

Assembling Foundation Tubes or Posts when Encountering Rock

Foundation Tubes

Complete the following steps to assemble foundation tubes when encountering rock:

1. Select Option A or Option B below when encountering rock, unless there is a more restrictive state/specifying agency specification.

Option A - If rock is encountered and 9" [225 mm] or less of the full length foundation tube remains to be embedded.

- A. Drill a 12" to 16" [300 to 400 mm] diameter hole into the rock.
- B. Drill the hole 3" [75 mm] deeper than the required embedment depth.
- C. Fill the hole with MSC.
- D. Place the foundation tube and rebar ring per the "Sleeve in a Concrete Footing (Poured Footing)" section.

Option B - If rock is encountered and more than 9" [225 mm] of the full length foundation tube remains to be embedded.

- A. Drill a 12" to 16" [300 mm to 400 mm] diameter hole into the rock. The minimum depth to the bottom of the hole from the ground line shall be 21" [525 mm]. The 21" [525 mm] includes 3" [75 mm] below the tube.
- B. Cut off the bottom end of the foundation tube so the top of the tube will be flush with finished ground.
- C. Follow the steps in C and D in "Option A" above.

Foundation Tubes with Soil Plates

For Foundation with Tubes with Soil Plates, remove the soil plate from the sleeve and follow the "Foundation Tube" steps above.

Driven Posts

For Driven Posts, it is recommended that the post be installed with a Foundation Tube. Follow the Foundation Tube steps above.

Bottom CRP-Posts 1 to 3 or 1x to 3

Complete the following steps to place Bottom CRP when encountering rock:

Select Option A or Option B below when encountering rock, unless there is a more restrictive state or specifying highway state/specifying agency specification.

Option A - If rock is encountered and 30" [750 mm] or less depth is required to complete the assembly of the full post:

1. Drill an 18" [450 mm] diameter hole into the rock.
2. Place the rebar cage and Bottom CRP in the hole. Complete the steps in the "Bottom CRP with Concrete Footings" section for the assembly of the rebar cage and the Bottom CRP.

Option B - If rock is encountered and more than 30" [750 mm] is required to complete the placement of the full rebar cage:

1. Drill an 18" [450 mm] diameter hole 33" [825 mm] into the rock.
2. Cut off the rebar cage so there will be 3" [75 mm] of concrete below the cage.
3. Follow the steps in C and D in "Option A" above.

Appendix D: Base Plated Post Assembly

The base plated post (PN-33915A) must be placed on a concrete surface 6" [150 mm] or more in depth (See Figure 15). The post length varies per concrete elevation. The center of the yielding holes are approximately 3'-2 7/8" from the top of the post.

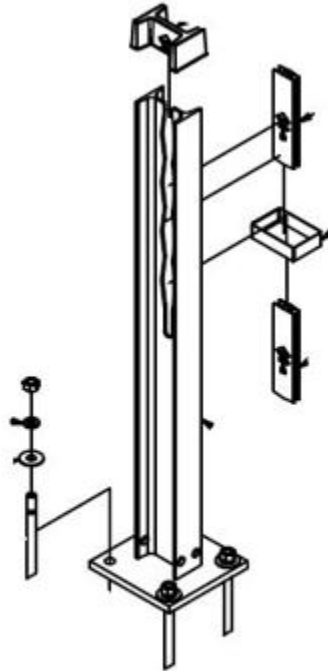

Figure 15
Base Plated Post

Complete the following steps for the base plated post assembly.

1. Drill four (4) 3/4" [19 mm] holes, 6" [150 mm] deep for the rod (PN-5225G or PN6722G).
2. Clean the holes according to the adhesive manufacturer's recommendations.
3. Place the rods and adhesive in the holes according to the manufacturer's recommendations.

Note: A 5/8" [16 mm] mechanical anchor with a pull out strength of 10,000 lbs. [4,536 kg] can also be used.

4. Allow the adhesive to cure according to the manufacturer's recommendations.
5. Place the base plated post on the rods.
6. Place flat washer (PN-3300G) and lock washer (PN-3310G) between the hex nut (PN-3361G) and the plate (See Figure 15).
7. Tighten the nuts to a snug position with an appropriately sized wrench or socket and the lock washer is flat with a minimum of two (2) threads showing.

Note: Base plated post assembly for below grade applications, contact Valtir.



For more complete information on Valtir products and services, visit us on the web at www.valtir.com. Materials and specifications are subject to change without notice. Please contact Valtir to confirm that you are referring to the most current instructions.

WWW.VALTIR.COM
1.888.356.2363