



# SRT™ 31 System

## FLARED END TERMINAL

### PRODUCT DESCRIPTION ASSEMBLY MANUAL

**PN 626825**

REVISION A APRIL 2023

# SRT™ 31 System

## Flared End Terminal

The Slotted Rail Terminal-31 System (“SRT™ 31 System”) has been tested to National Cooperative Highway Research Program (“NCHRP”) Report 350 criteria and has been deemed eligible for Federal-aid reimbursement on the National Highway System (“NHS”) by the Federal Highway Administration (“FHWA”).

## Product Description Assembly Manual



15601 Dallas Parkway  
Suite 525  
Addison, Texas 75001



**Warning:** The state/specifying agency, distributors, owners, and contractors are **RESPONSIBLE** for the assembly, maintenance, and repair of the SRT™ 31 System. Failure to fulfill these **RESPONSIBILITIES** with respect to the assembly, maintenance, and repair of the SRT™ 31 System could result in serious injury or death.



**Important:** These instructions are for standard assembly specified by the state/specifying agency. In the event the specified system assembly, maintenance, or repair would require a deviation from standard assembly parameters, contact a Valtir, LLC (“Valtir”) representative. This system has been deemed eligible by the FHWA for use on the NHS under strict criteria utilized by that state/specifying agency.

**This manual must be available to the worker overseeing and/or assembling the product at all times. For additional copies, contact Valtir at (888) 356-2363 or visit [Valtir.com/Products](https://www.valtir.com/Products).**

The information contained in this manual supersedes all previous versions. The instructions, illustrations, and specifications are based on the latest SRT™ 31 System information available to Valtir at publication. We reserve the right to make changes at any time. Please visit [Valtir.com/product-category/end-terminals](https://www.valtir.com/product-category/end-terminals) to confirm the latest revision.

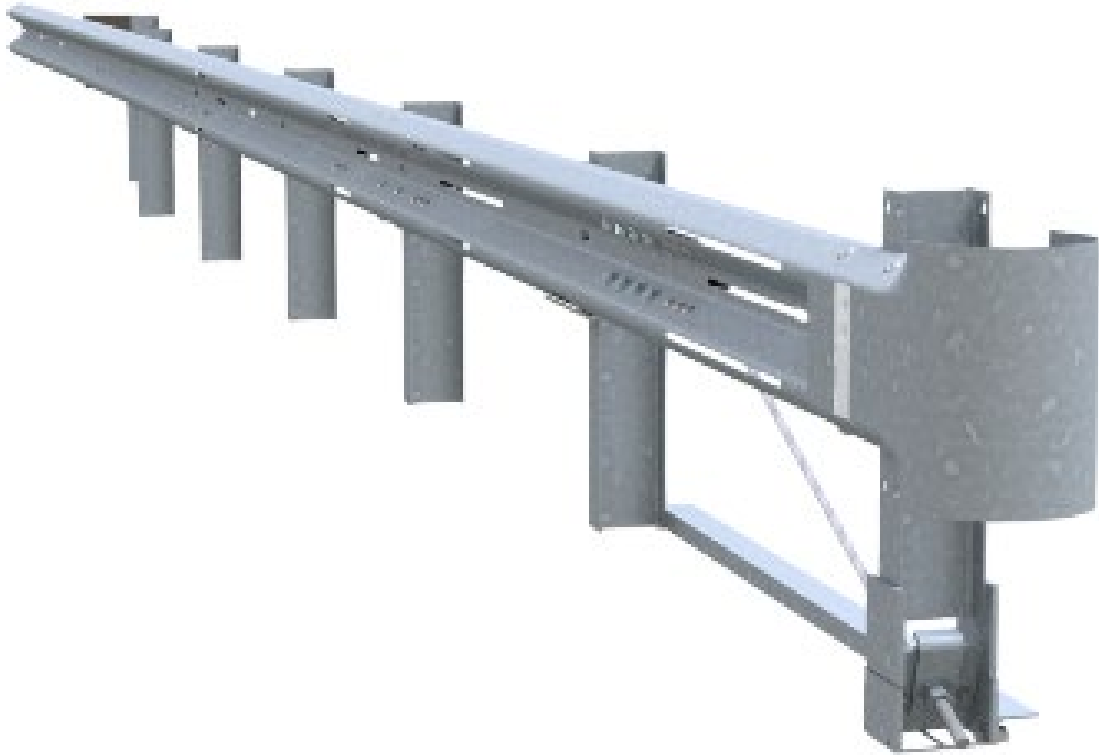

# **SRT™ 31 System**

## **Flared End Terminal**

The SRT™ 31 System is a straight flared, single-sided, re-directive, and gating end terminal.

# **Table of Contents**

SRT™ 31 System Acronyms .....	3
Customer Service Contacts .....	4
Limitations and Warnings .....	5
Overview .....	6
Inspect Shipment SRT™ 31 System .....	8
SRT™ 31 System Components/Hardware.....	9
Recommended Tools .....	12
Site Preparation .....	13
Post Placement .....	14
Rigid Pavement and Rock .....	14
Assembly Steps .....	14
STEP 1A: SRT™ 31 System (34'-4 1/2" Long) Post Layout .....	15
STEP 1B: SRT™ 31 System (40'-7 1/2" Long) Post Layout .....	16
STEP 2A: SRT™ 31 System (34'-4 1/2" Long) Post 2-6 Assembly .....	17
STEP 2B: SRT™ 31 System (40'-7 1/2" Long) Post 2-7 Assembly .....	18
STEP 3: CR Post 1 Bottom Assembly .....	19
STEP 4: CR Post 1 Top Assembly .....	20
STEP 5: SYTP® 2 Assembly .....	21
STEP 6: SYTP® 4 Assembly .....	22
STEP 7A: SRT™ System (34'-4 1/2" Long) SRT™-3 Guardrail Assembly .....	23
STEP 7B: SRT™ System (40'-7 1/2" Long) SRT™-3 Guardrail Assembly .....	24
STEP 8: SRT™ Systems SRT™-2 Guardrail Assembly .....	25
STEP 9: SRT™ Systems SRT™-1 Anchor Guardrail Assembly .....	26
STEP 10: SRT™ Slot Guard Assembly .....	27
STEP 11: SRT™ Anchor Bracket Assembly .....	28
STEP 12: SRT™ Anchor Cable Assembly .....	29
STEP 13: SRT™ Angle Strut Assembly .....	30
STEP 14: SRT™ Buffer Assembly .....	31
STEP 15: SRT™ Delineation Assembly .....	32
SRT™ 31 System Assembly Checklist (File With Project Records) .....	33
SRT™ 31 System Repair Checklist (File With Maintenance Records).....	34
SRT™ 31 Routine Inspection Checklist (File with Maintenance Records) .....	35
APPENDIX A: AASHTO Roadside Design Guide Grading Detail.....	36
APPENDIX B: Leave-Outs.....	37
APPENDIX C: Encountering Rock.....	38
NOTES.....	39

## **SRT™ 31 SYSTEM ACRONYMS**

AASHTO	American Association of State Highway and Transportation Officials
FHWA	Federal Highway Administration
CFR	Code of Federal Regulation
CR	Cable Release
MUTCD	Manual on Uniform Traffic Control Devices
NCHRP	National Cooperative Highway Research Program
NHS	National Highway System
OSHA	Occupational Safety & Health Administration
PPE	Personal Protective Equipment
SYTP®	Steel Yielding Terminal Post®
SRT™ 31 System	Slotted Rail Terminal-31 System
TL-X	Test Level X; X refers to the different Test Levels; 1, 2 or 3
Valtir	Valtir, LLC

## **Customer Service Contacts**

Valtir is committed to the highest level of customer service. Feedback regarding the SRT™ 31 System, its assembly procedures, supporting documentation, and performance is always welcome. Additional information can be obtained from the contact information below:

### **Valtir**

Telephone	(888) 356-2363 (USA) +1 214 589 8140 (International)
Contact Link	<a href="http://Valtir.com/Contact">Valtir.com/Contact</a>
Website:	www.Valtir.com

**Valtir, LLC**  
**15601 Dallas Parkway**  
**Suite 525**  
**Addison, TX 75001**



## **Limitations and Warnings**

Valtir, in compliance with NCHRP-350, contracts with ISO 17025 A2LA accredited testing laboratories to perform crash tests, evaluate tests, and submit the test results to the FHWA for review.

The SRT™ 31 System has been deemed eligible by FHWA as meeting the requirements and guidelines of NCHRP Report 350, Test Level 3 (“TL-3”). These tests typically evaluate product performance defined by NCHRP Report 350 involving a range of vehicles on roadways, from lightweight cars (approx. 800 kg [1800 lb.]) and full size pickup trucks (approx. 2,000 kg [4,400 lb.]) at 100 kph [62 mph].

**The SRT™ 31 System is tested pursuant to the test matrix criteria of NCHRP Report 350 as designated by FHWA. The FHWA tests are not intended to represent the performance of systems when impacted by every vehicle type or in every impact condition existing on the roadway. Every departure from the roadway is a unique event.**

Valtir expressly disclaims any warranty or liability for injury or damage to persons or property resulting from any impact, collision or harmful contact with its products, other vehicles, or nearby hazards or objects by any vehicle, object or person, whether or not the products were assembled in consultation with Valtir or by third parties.

The SRT™ 31 System is intended to be assembled, delineated, and maintained within state/specifying agency and federal guidelines. It is important for the state/specifying agency specifying the use of a highway product to select the most appropriate product configuration for site specifications.

**The state/specifying agency’s careful evaluation of the site layout, vehicle population type and speed, traffic direction, and visibility are some of the elements that require evaluation in the selection of a highway product. For example, curbs could cause an untested effect on an impacting vehicle.**

After an impact with the system, all debris must be removed from the area immediately in compliance with the most applicable state/specifying agency policy. The specified SRT™ 31 System must be evaluated and restored to its original specified condition or replaced as the state/specifying agency determines/requires, as soon as possible. Product selection, approval, proper installation, and maintenance of any highway product is the sole responsibility of the state/specifying agency and the state DOT.

Safety Alert Symbols appear throughout this manual and indicate Danger, Warning, Caution or Important statements. Failure to read and follow these warnings could result in serious injury or death in the event of a vehicle impact with the system.

**WARNING: Do not assemble, maintain, or repair the SRT™ 31 System until you have read this manual thoroughly and completely understand it. Ensure that all Danger, Warning, Caution, and Important statements within the manual are completely followed. Please call Valtir at (888) 356-2363 if you have any questions about instructions in this manual.**

**WARNING: Safety measures incorporating appropriate traffic control devices and personal protective equipment (“PPE”) specified by the state/specifying agency must be used to protect all personnel while at the assembly, maintenance, or repair site.**

**WARNING: Ensure the assembly site meets all appropriate Manual on Uniform Traffic Control Devices (“MUTCD”) and state/specifying agency standards.**

**WARNING: Only Valtir parts that are specified herein can be used for assembly, maintenance, or repair on them SRT™ 31 System. Do not utilize or otherwise commingle parts from other systems, even if those systems are other Valtir systems. Such configurations have not been tested, nor have they been approved for use. Assembly, maintenance or repairs using unspecified parts or accessories is strictly prohibited. Failure to follow this warning could result in serious injury or death in the event of a vehicle impact with such an UNACCEPTED system.**

**WARNING: Do NOT modify the SRT™ 31 System in any way.**

**IMPORTANT: Valtir makes no recommendation whether use or reuse of any part of the SRT™ 31 System is appropriate or acceptable after system impact. It is the responsibility of the state/specifying agency and its engineers to make that determination.**

**IMPORTANT: It is the responsibility of the applicable owner, state/specifying agency, or specifier to inspect the SRT™ 31 System after assembly is complete to ensure the instructions provided in this manual have been strictly followed.**

## Overview

The SRT™ 31 System is a straight flared, single-sided, re-directive, and gating end terminal. The SRT™ 31 System is a 31" [787 mm] high (measured from top of rail to finished grade) end terminal used to shield 31" [787 mm] high strong post W-beam guardrail.

The SRT™ 31 System consists of one (1) SRT™ Anchor Guardrail, and two (2) SRT Guardrails, Cable Release (CR) Post at post location 1, Steel Yielding Terminal Post® ("SYTP®") at post locations 2-6, SRT™ Angle Strut, SRT™ Cable Anchor Bracket and SRT™ Anchor Cable, SRT™ Shelf Angle at post 2, SRT™ Flange Protector at posts 2, 4, & 6, SRT™ Slot Guards downstream of slots, SRT™ Buffer, and various other required hardware accessories.

The CR Post 1 Bottom is fabricated from a W6x15# Structural Beam approximately 6'-3 1/2" [1.91 m] in length from top of the side plates to bottom of the embedded portion. Combined with the CR Post 1 Top, they become the SRT™ Anchor Post shown below.

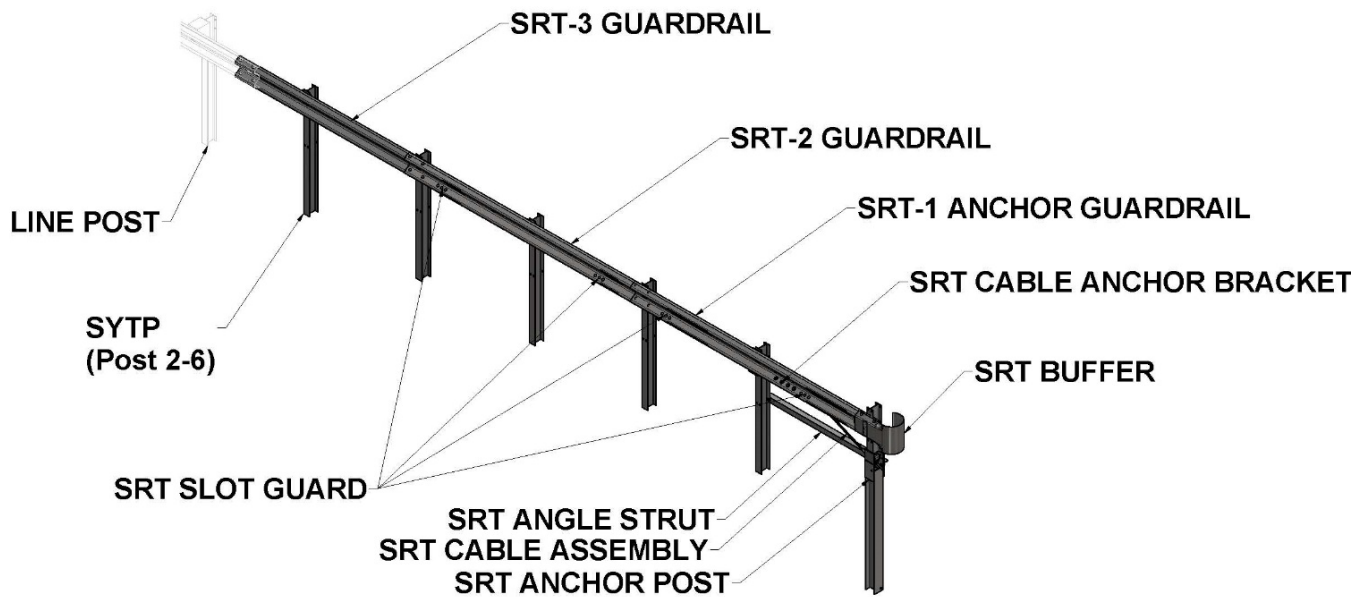

**SRT™ System (34'-4 1/2" Long - 31" High)**  
**Reference drawing: SS436**

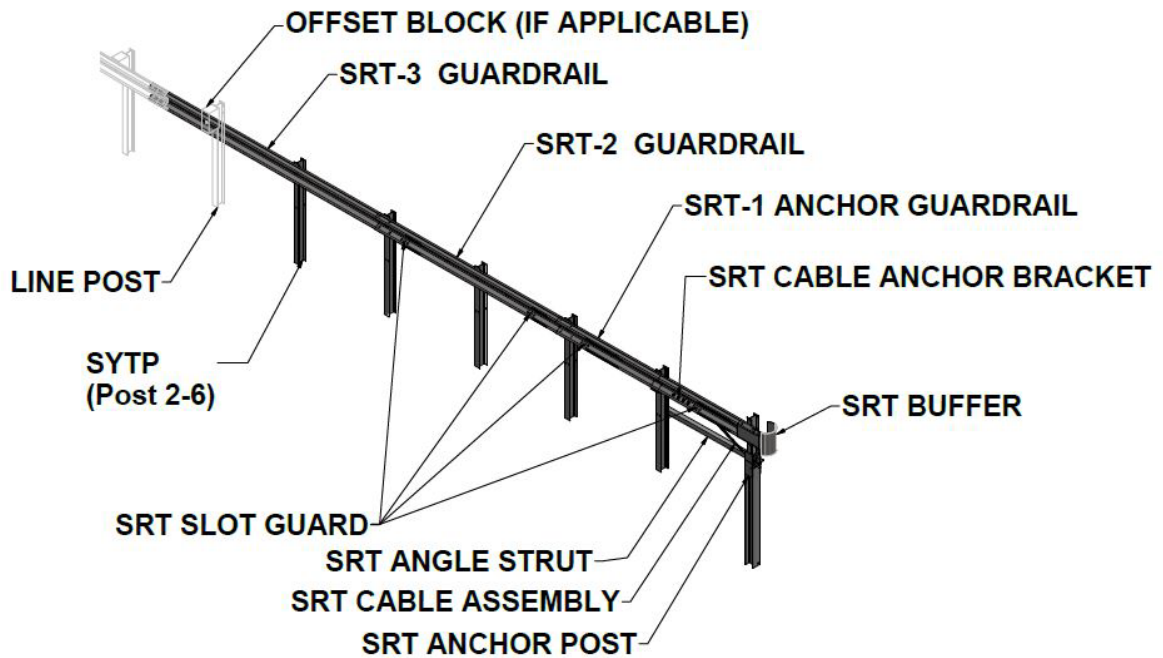

**SRT™ 31 System (40'-7 1/2" Long - 31" High)**

**Reference drawing: SS616**



## Inspect Shipment

Carefully unpack and inspect all components for damage. Check the received parts against the packing list supplied with the system. If any parts are damaged, missing, or unspecified; do not attempt to assemble the system and contact Valtir immediately (p. 4).





**Warning: Use only Valtir parts that are specified by Valtir for use with the SRT™ 31 System for assembling, maintaining, or repairing the SRT™ 31 System. Do not utilize or otherwise commingle parts from other systems even if those systems are other Valtir Systems.**



ID	SRT™ 31 SYSTEM COMPONENTS/HARDWARE	PN	SS 436 34'-4½"	SS 616 40'-7½"
A	SRT™-1 Anchor Guardrail 12'-6" [3.810 m]	30G	1	1
B	SRT™-2 Guardrail 12'-6" [3.810 m]	39G	1	1
C	SRT™-3 Guardrail 9'-4 1/2" [2.857 m]	10967G	1	0
D	CR Post 1 Bottom W6 x 15# [W6 x 22.5 kg]	34052A	1	1
E	CR Post 1 Top W6 x 8.5# [W150 x 13 kg]	34053A	1	1
F	SYTP® 6'-0" [1.83 m]	15000G	5	5
G	SRT™ Flange Protector at Posts 2,4,6	7G	3	3
I	SRT™ Cable Anchor Bracket	700A	1	1
K	SRT™ Angle Strut 3" x 3" x 1/4" [75 mm x 75 mm x 6 mm]	33875G	1	1
L	SRT™ Shelf Angle (At Post 2)	34054G	1	1
M	SRT™ Buffer	907G	1	1
N	SRT™ Cable Assembly 3/4" x 6'-6"	3000G	1	1
O	5/16" x 1.75" Hex Bolt (At Post 1)	4211G	2	2
P	SRT™ Slot Guard - <b>NOTE Orientation of Arrows</b>	9960G	4	4
Q	SRT™ Cable Anchor Bracket Angle (At Post 1)	33909G	1	1
R	5/8" x 2" HGR Post Bolt (At Posts 1, 2, & 4)	3400G	4	4
S	5/8" x 1.75" Countersunk HD Bolt (At Post 6)	4419G	1	1
T	1" Hex Nut (At Cable Ends)	3910G	2	2
U	5/8" x 1.25" GR Bolt	3360G	52	52
V	1" Round Washer (At Cable Ends)	3900G	2	2
W	5/8" x 1.5" Hex Bolt	3380G	8	8
X	5/8" x 1.75" Hex Bolt (A325) (At Strut)	3391G	2	2
Y	5/16" Round Washer (At Post 1)	3240G	2	2
Z	SRT™-3 Guardrail 15'-7 1/2" [4.762 m]	20442G	0	1
AA	5/8" Round Washer	3300G	12	12
BB	5/8" GR Hex Nut	3340G	67	67
CC	5/16" Hex Nut (At Post 1)	3245G	2	2
DD	DELINEATION OPTIONS: Reflective Sheeting 16" x 16" [400 mm x 400 mm] Striped Yellow/Black	6665B	1	1
EE	16" x 16" [400 mm x 400 mm] Solid Yellow	6666B	1	1
	Both 6665B and 6666B can be used for Left or Right applications or use the state standards.			

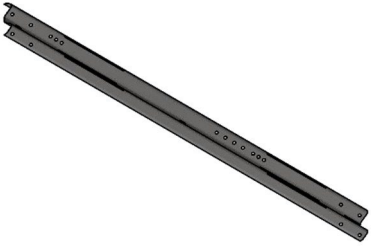
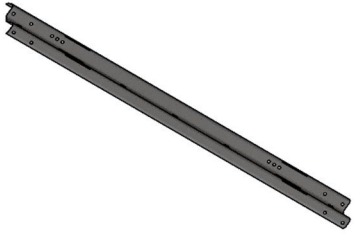

## **SRT™ 31 System Components/Hardware**



Below is a pictorial depiction of the components/hardware for SRT™ 31 System. Please see the Valtir drawings and page 8 of this manual for specific lists of components/hardware and quantities required for SRT™ 31 System selected to be assembled.

**Note:** The following components/hardware are not shown to scale.

ID: A	PN: 30G	ID: B	PN: 39G	ID: C	PN: 10967G
					
SRT™-1 Anchor Guardrail 12'-6"		SRT™-2 Guardrail 12'-6"		SRT™-3 Guardrail 9'-4 1/2"	

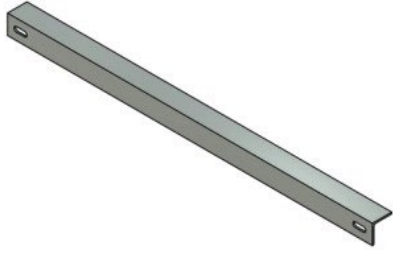
ID: D	PN: 34052A	ID: E	PN: 34053A	ID: F	PN: 15000G
					
CR Post 1 Bottom		CR Post 1 Top		SYTP® 6'-0"	

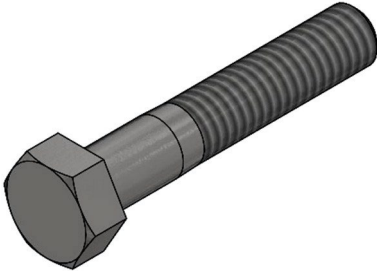
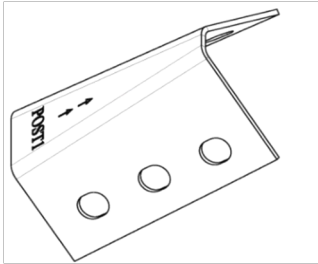
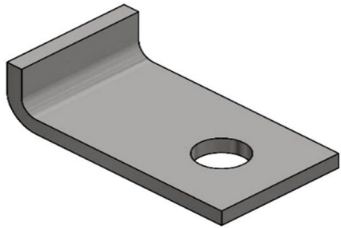

ID: G	PN: 7G	ID: I	PN: 700A	ID: K	PN: 33875G
					
SRT™ Flange Protector		SRT™ Cable Anchor Bracket		SRT™ Angle Strut	

ID: L	PN: 34054G	ID: M	PN: 907G	ID: N	PN: 3000G
					
SRT™ Shelf Angle		SRT™ Buffer		SRT™ Cable Assembly 3/4" x 6'-6"	

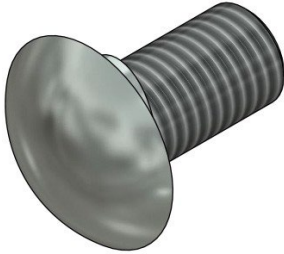
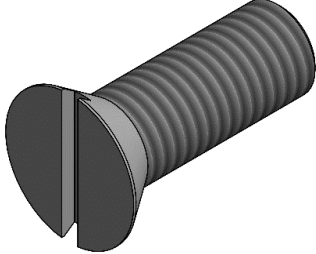
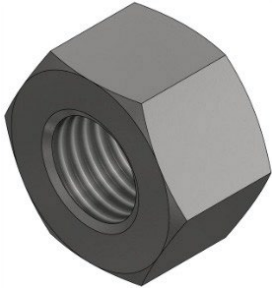
ID: O	PN: 4211G	ID: P	PN: 9960G	ID: Q	PN: 33909G
					
5/16" x 1.75" Hex Bolt		SRT™ Slot Guard		SRT™ Cable Anchor Bracket Angle	

ID: R	PN: 3400G	ID: S	PN: 4419G	ID: T	PN: 3910G
					
5/8" x 2" HGR Post Bolt		5/8" x 1.75" C.S. HD Bolt		1" Hex Nut	

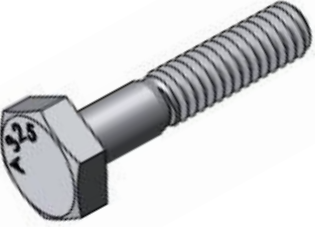
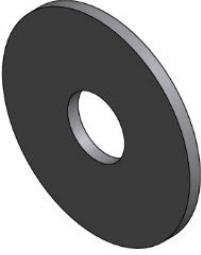
ID: U	PN: 3360G	ID: V	PN: 3900G	ID: W	PN: 3380G
					
5/8" x 1.25" GR Bolt		1" Round Washer		5/8" x 1.5" Hex Bolt	

ID: X	PN: 3391G	ID: Y	PN: 3240G	ID: Z	PN: 20442G
					
5/8" x 1.75" Hex Bolt (A325)		5/16" Round Washer		SRT™-3 Guardrail 15' 7 1/2"	

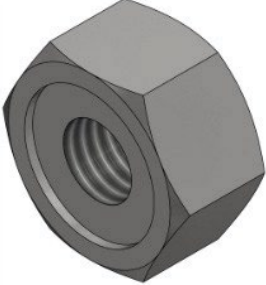
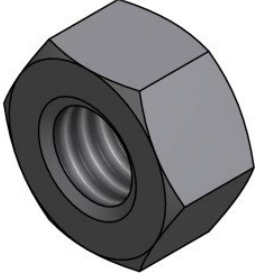
ID: AA	PN: 3300G	ID: BB	PN: 3340G	ID: CC	PN: 3245G
					
5/8" Round Washer		5/8" GR Hex Nut		5/16" Hex Nut	

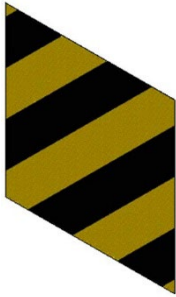
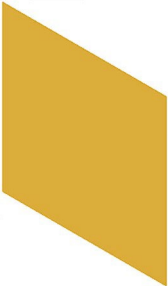
ID: DD	PN: 6665B	ID: EE	PN: 6666B
			
Delineation Striped Yellow/Black		Delineation Solid Yellow	

Both 6665B and 6666B can be used for Left or Right applications

# **Recommended Tools**

## **Documentation**

- Manufacturer's SRT™ 31 Product Description Assembly Manual (Current Version)
- SRT™ 31 System Drawing(s). Current Version of SS 436 or SS 616

## **Personal Protective Equipment**

- Eye Protection
- Work Gloves
- Safety-Toe Shoes
- Back Protection
- Hard Hat
- Reflective Vest
- Apron

## **Miscellaneous**

- Traffic Control Equipment and Plan per local standards and the MUTCD
- SAE Combination Wrench Set
- Socket Set & Socket Wrench
- Hammer
- Chalk Line
- Tape Measure
- Marking Paint and Pen
- Straight Edge
- Level
- Plumb Line
- Post Pounder (commonly used for driving posts)
- Auger
- Soil Tamper
- 5/8" Alignment Tool (Drift Pin)
- Locking Pliers

**Note:** The provided list of tools is a general recommendation and should not be considered an extensive list. Depending on specific site conditions and the complexity of the assembly specified by the state/specifying agency, the required tools may vary. Decisions as to what tools are needed to perform the job are entirely the responsibility of the state/specifying agency and the selected contractor performing the assembly of the system at the state/specifying agency's site.

## **Site Preparation**

The SRT™ 31 System is a straight flared, single-sided, re-directive, and gating end terminal. It may be specified for use by the state/specifying agency in conjunction with strong post W-beam guardrail systems on the roadside or median of a roadway. The decision to specify the SRT™ 31 System for a particular project is the responsibility of the state/specifying agency design engineer who must ensure that the most appropriate end terminal has been selected for the specific site conditions.

The SRT™ 31 System is designed to be attached to strong post W-beam guardrail systems that have been accepted under NCHRP Report 350 crash test criteria that use either no offset blocks, 8" [203 mm] offset blocks or 12" [305 mm] offset blocks.



**Important:** The SRT™ 31 System must not be attached directly to a weak post W-beam guardrail system without an approved weak-post-to-strong-post transition plus a minimum of 12'-6" [3.81 m] strong post W-beam guardrail with 6'-3" [1.91 m] post spacing. The 12'-6" [3.81 m] strong post W-beam guardrail must be placed between the SRT™ 31 System and the weak-post-to-strong-post transition.



**Important:** The SRT™ 31 System must not be attached directly to Thrie Beam, Thrie Beam Transition, or to a post which is stronger/stiffer than a standard W-beam W6x8.5# [W150x13] or W6x9# [W150x13.5] guardrail post. A minimum of 6'-3" [1.91 m] strong post single ply W-beam guardrail must be placed between the SRT™ 31 System and the Thrie Beam transition (or stronger/stiffer post).



**Important:** Do not attach the SRT™ 31 System directly to a rigid barrier (i.e. concrete barrier, wall or bridge pier) without the use of a state/specifying agency approved transition.



**Important:** Ensure that the SRT™ 31 System application conforms to the AASHTO Roadside Design Guide.



**Important:** Valtir does not direct grading. Proper site grading must be accomplished before assembly of the SRT-31 System in accordance with local guidelines OR the AASHTO Roadside Design Guide (see Appendix A), whichever is more stringent. Failure to follow this warning could result in serious injury or death in the event of a vehicle impact with the system.



**Important:** The Beginning Length of Need ("BLON") for the SRT™ 31 System was established during NCHRP Report 350 Test 3-35 at Post #3, which is 12'-6" [3.81 m] from the center of Post #1.



**Important:** A minimum of 75' [22.86 m] of strong post W-beam guardrail with 6'-3" [1.90 5m] post spacing must be placed between two SRT™ 31 Systems when installed with both an approach and departing end on NCHRP Report 350 TL-3 roadway applications. For roadway applications that meet the NCHRP Report 350 Test Level 2 (TL-2) or Test Level 1 (TL-1) criteria, the SRT™31 TL-3System can be placed "end to end", if specified and approved by the state/specifying agency. The minimum installation length for TL-2 and TL-1 applications is 81'-3" [24.77 m] long consisting of two (2) 40'-7 1/2" [12.38 m] Systems or two (2) 34'-4 1/2" [412.5 m] Systems plus one (1) 31" high, 12'-6" [3.81 m] strong post single ply 12 gauge W-beam guardrail system.

# **SRT™ 31 System Post Placement**

The SRT™ 31 System posts may be inserted into the soil using an auger or post pounding equipment for placement of guardrail posts. If an auger is used, ensure diameter is large enough to allow for proper compaction of state/specifying agency approved fill material. All SRT™ 31 System posts must be assembled within established standard construction tolerances, including being plumb. Compaction for all posts must be within state/specifying agency guidelines.



**Danger:** It is the responsibility of the installer to ensure all above & below ground utilities as well as drainage structures are located, marked, and identified prior to using an auger or post pounding tool in accordance with state/specifying agency guidelines. Failure to follow this warning could result in serious injury or death.

## **Rigid Pavement and Rock**

If rigid pavement (e.g. concrete or asphalt) of any thickness is encountered within the system pay length, ensure a proper “leave-out” area (the specified size of open space as defined in the AASHTO Roadside Design Guide) is provided around the posts and filled with state/specifying agency approved backfill material. See Appendix B for “leave-out” requirements of the SYTP®.

If rock is encountered within the system pay length, follow the criteria as defined in the AASHTO Roadside Design Guide. See Appendix C for requirements for the assembly of the CR Post 1 Bottom or SYTP®.



### **Drilling Holes into Rock**

**Caution:** It is the responsibility of the installer to consult Occupational Safety & Health Administration (“OSHA”) silica respiratory standard 29 Code of Federal Regulation (“CFR”) 1910.134 for debris removal and ensure compliance.

## **Assembly Steps**



**NOTE:** The order in which the steps appear in this manual are not necessarily the order in which they must be followed. **ALL STEPS MUST BE COMPLETED.**



**Important:** Valtir does not direct grading. Proper site grading must be accomplished before assembly of the SRT™ 31 System in accordance with state/specifying agency guidelines OR the AASHTO Roadside Design Guide (see Appendix A), whichever is more stringent. Failure to follow this warning could result in serious injury or death in the event of a vehicle impact with the system.

**Note:** Below ground portions in the assembly steps are not shown for clarity.

# STEP 1A

## SRT™ 31 System (34'-4 1/2" Long) Post Layout

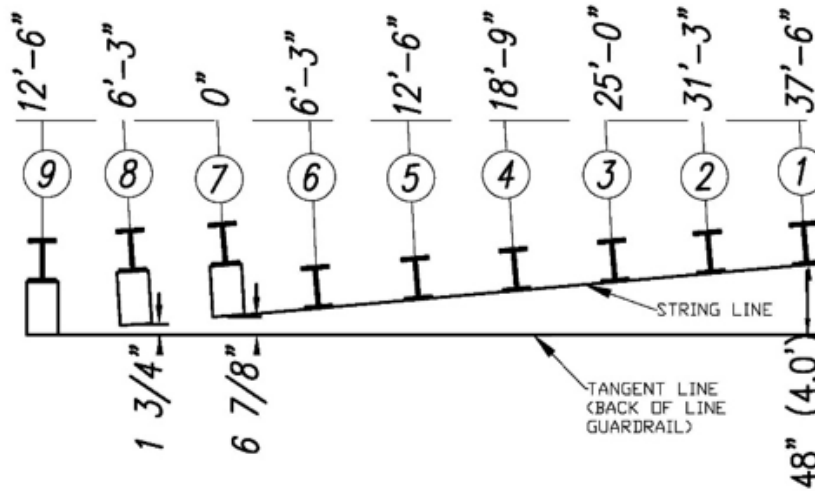
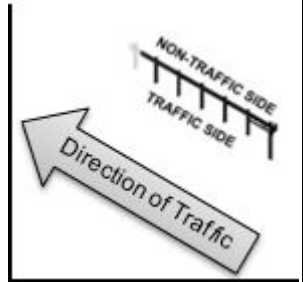

All post spacing is 6'-3" [1.903 m] On Center Typical. Post 7, 8 and 9 are not part of the SRT™ 31 System. The offset for posts 7, 8 and 9 is based on the depth of the block out or no block out of the downstream line guardrail.

PARTS			INSTRUCTIONS		
			<b>Reference Drawing SS436</b> 1. Layout the post as shown above. 2. Posts 6-2 are to be aligned with the string line between the block face of Post 7 or the face of Post 7 (for no block systems) and the face of Post 1. 3. Layout and placement of the posts are critical to the assembly of the SRT™ 31.		
Use only Valtir parts that are specified herein for the SRT™ 31 System for assembling, maintaining, or repairing the SRT™ 31 System. <u>Do not utilize or otherwise commingle parts from other systems even if those systems are Valtir systems.</u>			WARNINGS		
			 Ensure proper site grading in accordance with state/specifying agency guidelines or the AASHTO Roadside Design Guide, whichever is more stringent. Failure to follow this warning could result in serious injury or death in the event of a vehicle impact with the system.		



# STEP 1B

## SRT™ 31 System (40'-7 1/2" Long) Post Layout

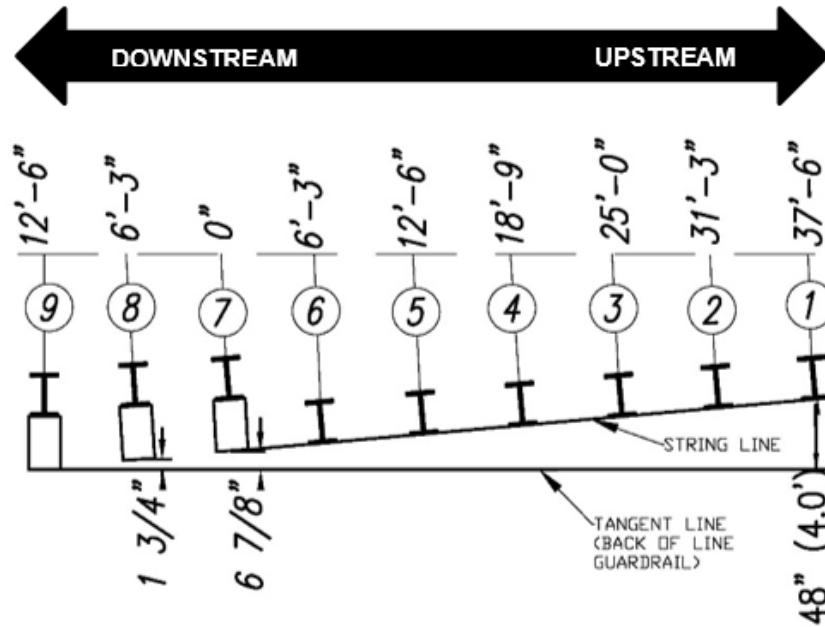



All post spacing is 6'-3" [1.903 m] On Center Typical. Post 7, 8 and 9 are not part of the SRT™ 31 System. The offset for posts 7, 8 and 9 is based on the depth of the block out or no block out of the downstream line guardrail.

PARTS			INSTRUCTIONS
			<p><b>Reference Drawing SS616</b></p> <ol style="list-style-type: none"> <li>1. Layout the post as shown above.</li> <li>2. Posts 6-2 are to be aligned with the string line between the block face of Post 7 or the face of Post 7 (for no block systems) and the face of Post 1.</li> <li>3. Layout and placement of the posts are critical to the assembly of the SRT™ 31.</li> </ol>
<p>Use only Valtir parts that are specified herein for the SRT™ 31 System for assembling, maintaining, or repairing the SRT™ 31 System. <u>Do not utilize or otherwise commingle parts from other systems even if those systems are Valtir systems.</u></p>			<p><b>WARNINGS</b></p> <div style="display: flex; align-items: center;"> <p>Ensure proper site grading in accordance with state/specifying agency guidelines or the AASHTO Roadside Design Guide, whichever is more stringent. Failure to follow this warning could result in serious injury or death in the event of a vehicle impact with the system.</p> </div>

# STEP 2A

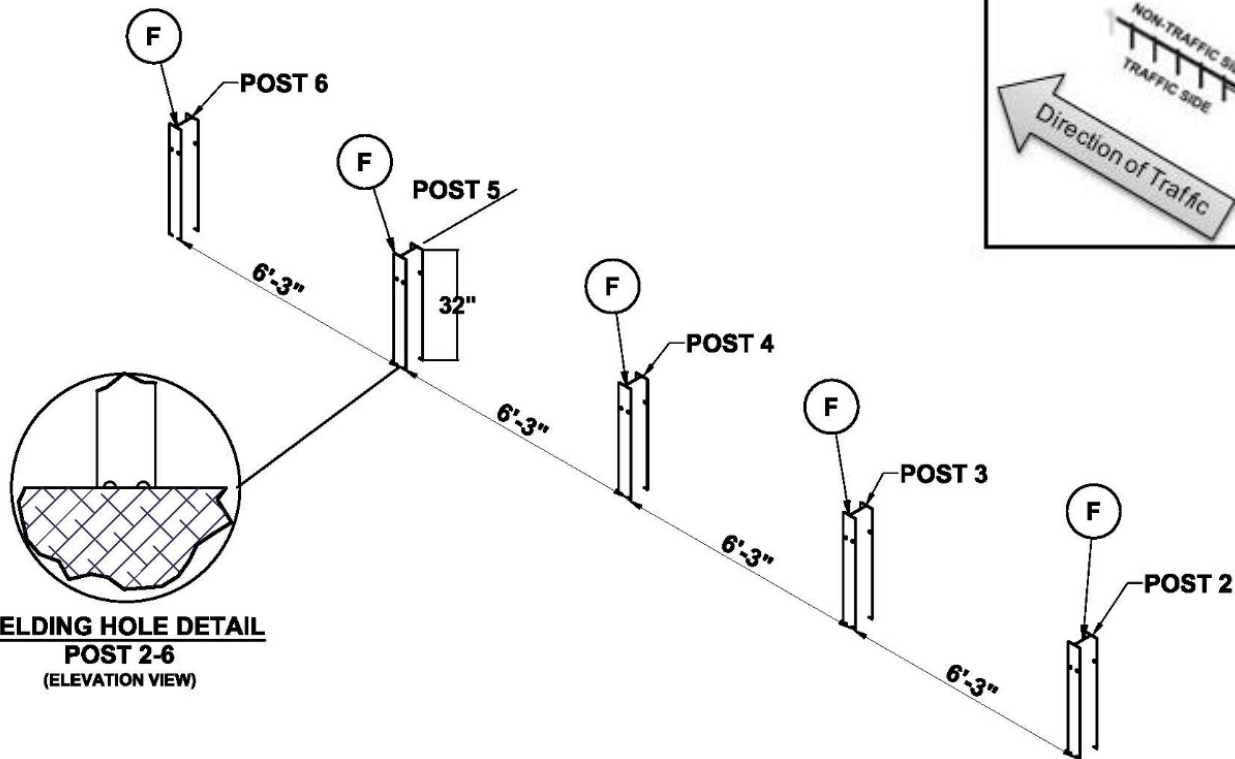
## SRT™ 31 System (34'-4 1/2" Long) Post 2-6 Assembly



PARTS			INSTRUCTIONS
F	15000G	5 EA	<b>Reference Drawing SS436</b> 1. Assemble all parts in the configuration and orientation as shown above. 2. The SRT™ 31 System must be attached to a 31" [787 mm] high strong post W-beam guardrail system or to a strong post W-beam guardrail that has been properly transitioned to 31" [787 mm] rail height per state/specifying state/specifying agency. 3. Ensure proper post spacing and post height are achieved for 6' SYTP® 2-6 (Part F) per shown dimensions above. 4. Ensure the center of the SYTP® yielding holes are approximately at finished grade as shown.
Use only Valtir parts that are specified herein for the SRT™ 31 System for assembling, maintaining, or repairing the SRT™ 31 System. <u>Do not utilize or otherwise commingle parts from other systems even if those systems are Valtir systems.</u>			<b>WARNINGS</b>  Ensure proper site grading in accordance with state/specifying agency guidelines or the AASHTO Roadside Design Guide, whichever is more stringent. Failure to follow this warning could result in serious injury or death in the event of a vehicle impact with the system.

# STEP 2B

## SRT™ 31 System (40'- 7 1/2" Long) Post 2-7 Assembly

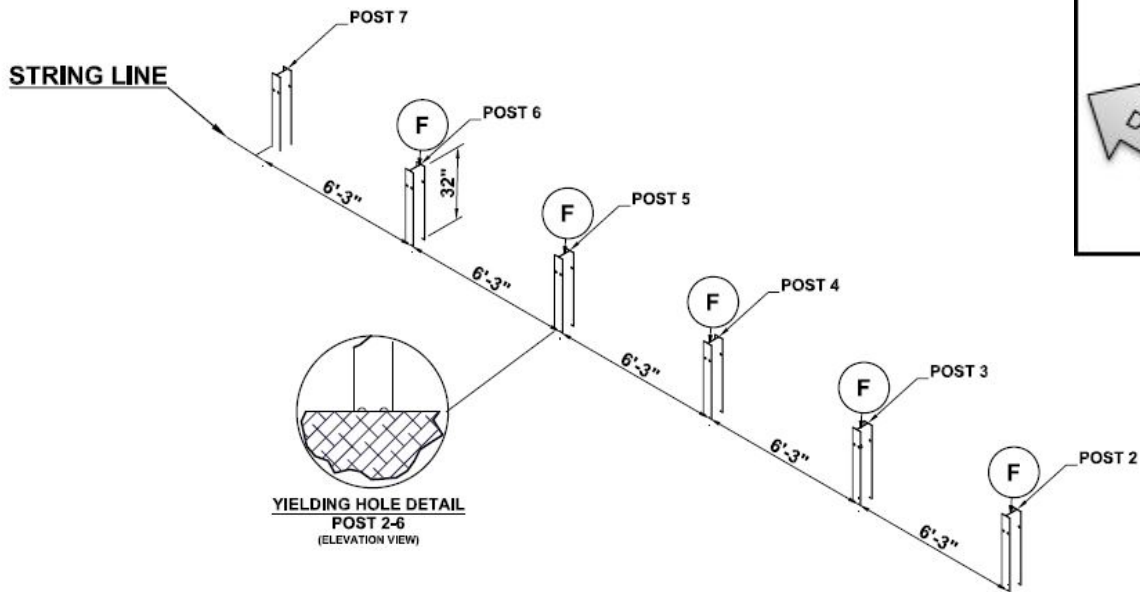

The offset for posts 7 is based on the depth of the blockout or no blockout of the downstream line guardrail. Post 7 is not part of the SRT™ 31 System Bill of Materials. Post 7 is part of the line

PARTS			INSTRUCTIONS
-------	--	--	--------------

F	15000G	5 EA

- Reference Drawing SS616**
1. Assemble all parts in the configuration and orientation as shown above.
  2. The SRT™ 31 System must be attached to a 31" [787 mm] high strong post W- beam guardrail system or to a strong post W-beam guardrail that has been properly transitioned to 31" [787 mm] rail height per state/specifying agency.
  3. Ensure proper post spacing and post height are achieved for 6' SYTP® 2-6 (Part F) and post 7 per shown dimensions above.
  4. Ensure the center of the SYTP® yielding holes are approximately at finished grade as shown.
  5. Post 7 is a standard 6' [1.83 m] long W6x8.5# [W150x13 kg] or W6x9# [W150x13.5 kg] guardrail post.

WARNINGS		
----------	--	--

Use only Valtir parts that are specified herein for the SRT™ 31 System for assembling, maintaining, or repairing the SRT™ 31 System. Do not utilize or otherwise commingle parts from other systems even if those systems are Valtir systems.

Ensure proper site grading in accordance with state/specifying agency guidelines or the AASHTO Roadside Design Guide, whichever is more stringent. Failure to follow this warning could result in serious injury or death in the event of a vehicle impact with the system.

# STEP 3

## CR Post 1 Bottom Assembly

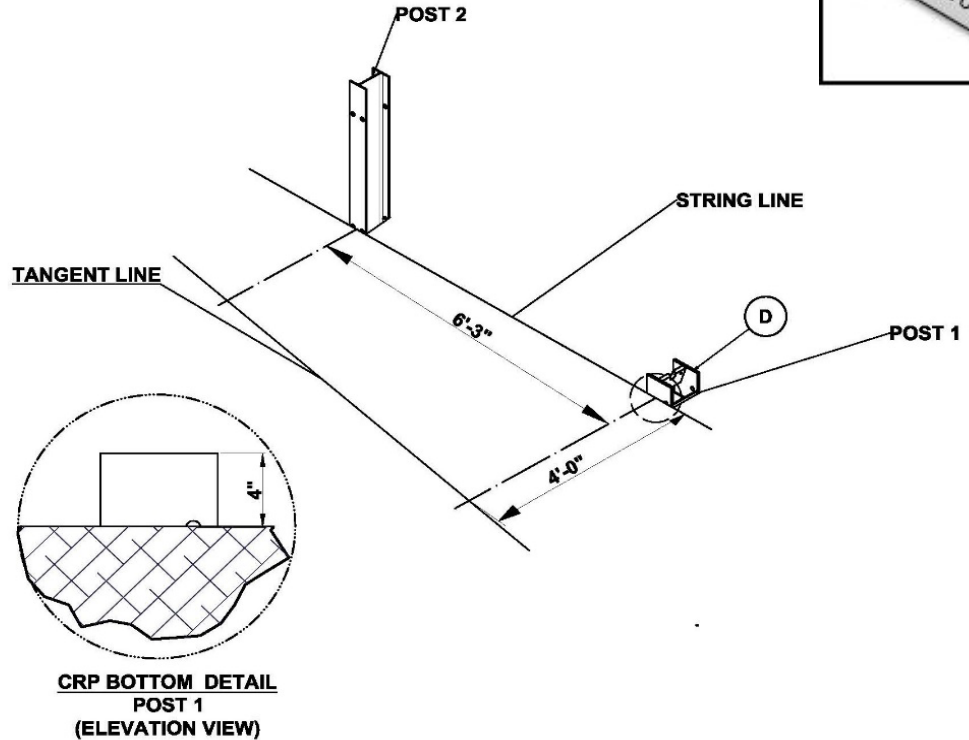

PARTS			INSTRUCTIONS
D	34052A	1 EA	<ol style="list-style-type: none"> <li>Assemble the CR Post 1 Bottom (Part D) in the configuration and orientation as shown above.</li> <li>Ensure the CR Post 1 Bottom is installed approximately plumb and oriented with the hole being closest to the upstream end of the CR Post 1 Bottom.</li> <li>Ensure the top of the CR Post 1 Bottom does not exceed 4" [100 mm] above finished grade.</li> <li>Ensure the CR Post 1 Bottom Strut Hole is assembled on the upstream side of the post.</li> </ol>

Use only Valtir parts that are specified herein for the SRT™ 31 System for assembling, maintaining, or repairing the SRT™ 31 System. Do not utilize or otherwise commingle parts from other systems even if those systems are Valtir systems.

WARNINGS	
	<p>Ensure proper site grading in accordance with state/specifying agency guidelines or the AASHTO Roadside Design Guide, whichever is more stringent. Ensure the CR Post 1 Bottom is oriented correctly and the height does not exceed 4" [100 mm] above finished grade. Failure to follow this warning could result in serious injury or death in the event of a vehicle impact with the system</p>

# STEP 4

## CR Post 1 Top Assembly

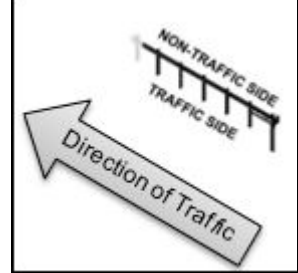
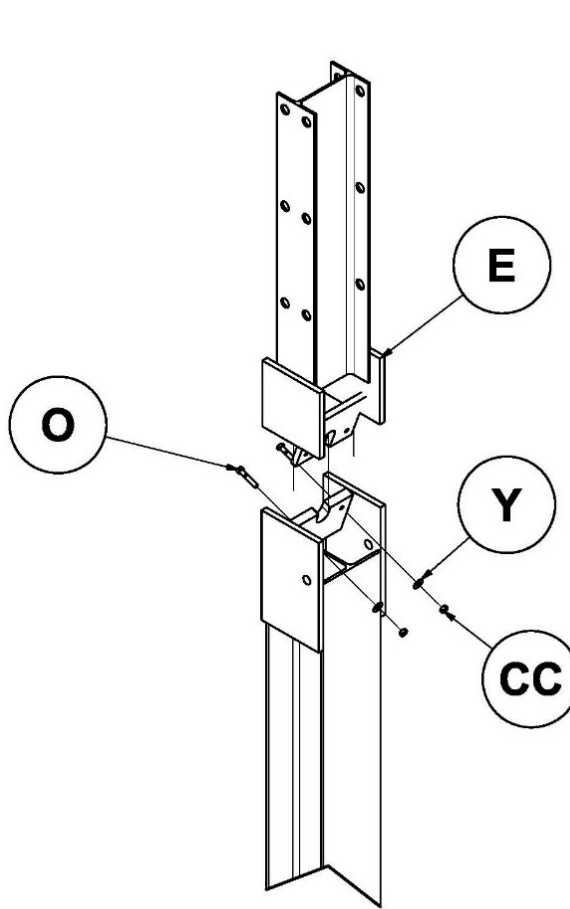

PARTS			INSTRUCTIONS
E	34053A	1 EA	<ol style="list-style-type: none"> <li>Assemble the CR Post 1 Top (Part E) to the CR Post 1 Bottom as shown above.</li> <li>Tighten all threaded hardware to a snug position with a minimum of two (2) bolt threads protruding beyond the nut.</li> </ol>
O	4211G	2 EA	
Y	3240G	2 EA	
CC	3245G	2 EA	

Use only Valtir parts that are specified herein for the SRT™ 31 System for assembling, maintaining, or repairing the SRT™ 31 System. Do not utilize or otherwise commingle parts from other systems even if those systems are Valtir systems.

### WARNINGS



Ensure the CR Post 1 Top and CR Post 1 Bottom are oriented correctly. Failure to follow this warning could result in serious injury or death in the event of a vehicle impact with the system.

# STEP 5

## SYTP® 2 Assembly

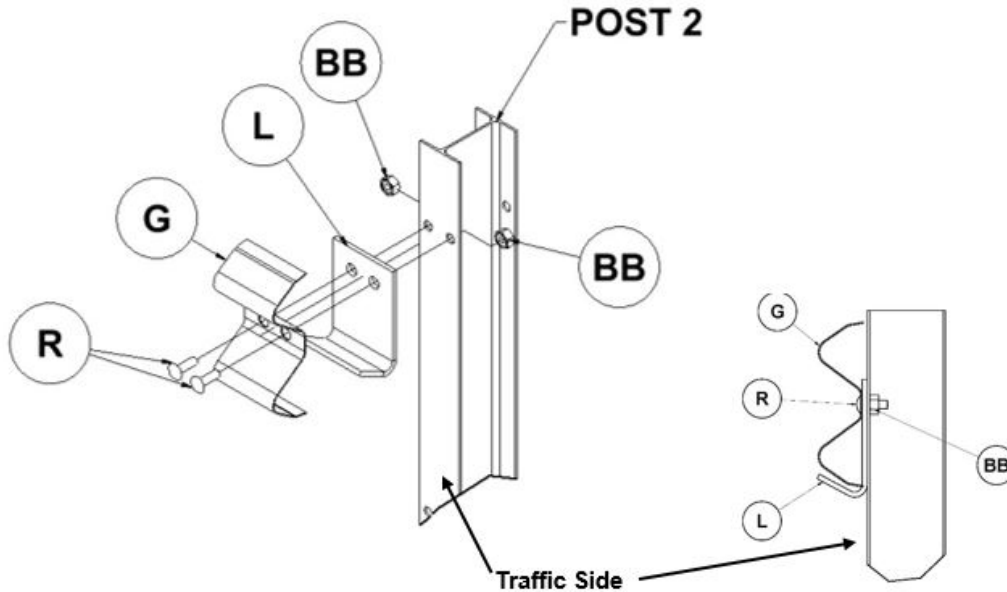

**COMPLETED ASSEMBLY DETAIL**

PARTS			INSTRUCTIONS
G	7G	1 EA	<ol style="list-style-type: none"> <li>1. Assemble the components to SYTP® 2 on the traffic side as shown above.</li> <li>2. Assemble the SRT™ Flange Protector (Part G) as shown above.</li> <li>3. Ensure it is seated correctly <b>inside</b> the hook of the SRT™ Shelf Angle (Part L) as shown in the <b>COMPLETED ASSEMBLY DETAIL</b>.</li> <li>4. Tighten all threaded hardware to a snug position with a minimum of two (2) bolt threads protruding beyond the nut.</li> </ol>
L	34054G	2 EA	
R	3400G	2 EA	
BB	3340G	2 EA	
Use only Valtir parts that are specified herein for the SRT™ 31 System for assembling, maintaining, or repairing the SRT™ 31 System. <u>Do not utilize or otherwise commingle parts from other systems even if those systems are Valtir systems.</u>			WARNINGS
			 Ensure the SRT™ Flange Protector (Part G) is seated correctly <b>inside</b> the hook of the SRT™ Shelf Angle (Part L) as shown in the COMPLETED ASSEMBLY DETAIL, and is located on the traffic side of the post.

# STEP 6

# SYTP® 4 Assembly

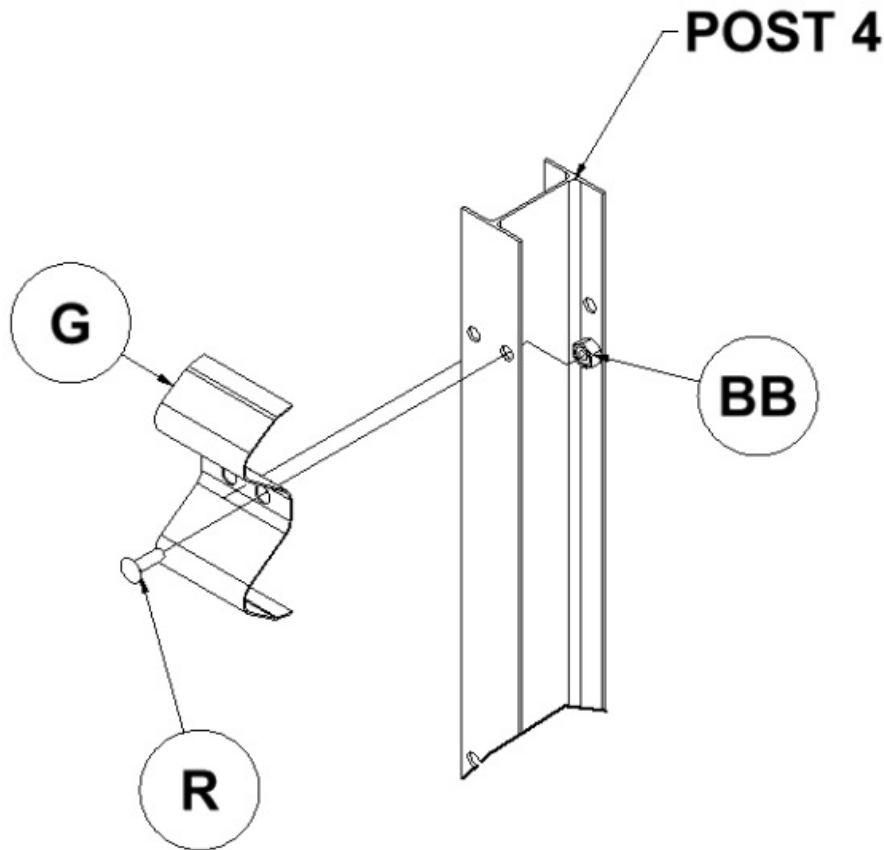

PARTS			INSTRUCTIONS
G	7G	1 EA	<ol style="list-style-type: none"> <li>1. Assemble the components to SYTP® 4 as shown above with the SRT™ Flange Protector (Part G) installed on traffic side of post.</li> <li>2. Bolt can be installed in either hole.</li> <li>3. Tighten all threaded hardware to a snug position with a minimum of two (2) threads protruding beyond the nut.</li> </ol>
R	3400G	1 EA	
BB	3340G	1 EA	

Use only Valtir parts that are specified herein for the SRT™ 31 System for assembling, maintaining, or repairing the SRT™ 31 System. Do not utilize or otherwise commingle parts from other systems even if those systems are Valtir systems.

### WARNINGS



Ensure the SRT™ Flange Protector (Part G) is installed on traffic side of post.

# STEP 7A

## SRT™ 31 System (34'-4 1/2" Long) SRT™-3 Guardrail Assembly

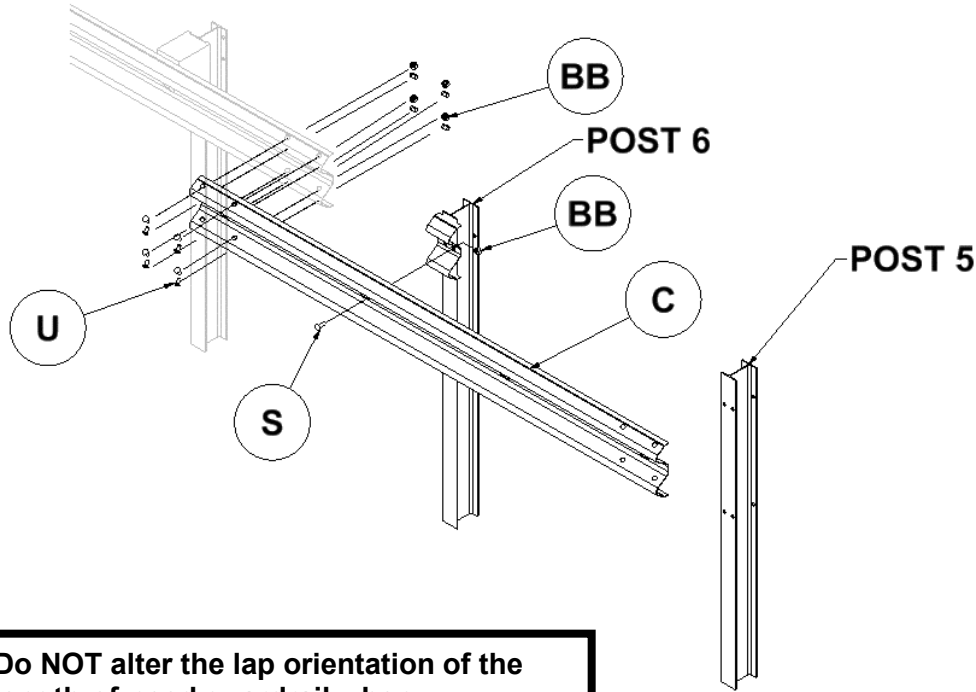

**Do NOT alter the lap orientation of the length-of-need guardrail when assembling a downstream/trailing end**

C	10967G	1 EA	<b>Reference Drawing SS436</b> 1. Assemble the SRT™-3 Guardrail (Part C) as shown above. 2. Ensure the SRT™-3 Guardrail is straight between Posts 7 and 5 and the height is 31" above grade. 3. Ensure any gap between the back of the SRT™-3 Guardrail and the face of the SYTP® or SRT™ flange protector does not exceed 2" [50 mm]. 4. <b>Ensure SRT™-3 Guardrail is lapped in the direction of traffic immediately adjacent to the SRT™ 31 installation.</b> 5. Ensure 5/8" x 1.75" countersunk HD bolt (Part S) is used to attach the SRT™-3 Guardrail to Post 6. 6. Tighten all threaded hardware to a snug position with a minimum of two (2) bolt threads protruding beyond the nut.
S	4419G	1 EA	
U	3360G	8 EA	
BB	3340G	9 EA	

Use only Valtir parts that are specified herein for the SRT™ 31 System for assembling, maintaining, or repairing the SRT™ 31 System. Do not utilize or otherwise commingle parts from other systems even if those systems are Valtir systems.

### WARNINGS



Do not attach the SRT™-3 Guardrail to post 5. Do not place anything between the post bolt head and the SRT™ 31 Anchor Guardrail that would prevent the bolt from pulling through (i.e. no rectangular washer or delineator). Ensure the SRT™-3 Guardrail is straight between posts 7 and 5. Failure to follow this warning could result in serious injury or death in the event of a vehicle impact with the system.



# STEP 7B

## SRT™ 31 System (40'-7 1/2" Long) SRT™-3 Guardrail Assembly

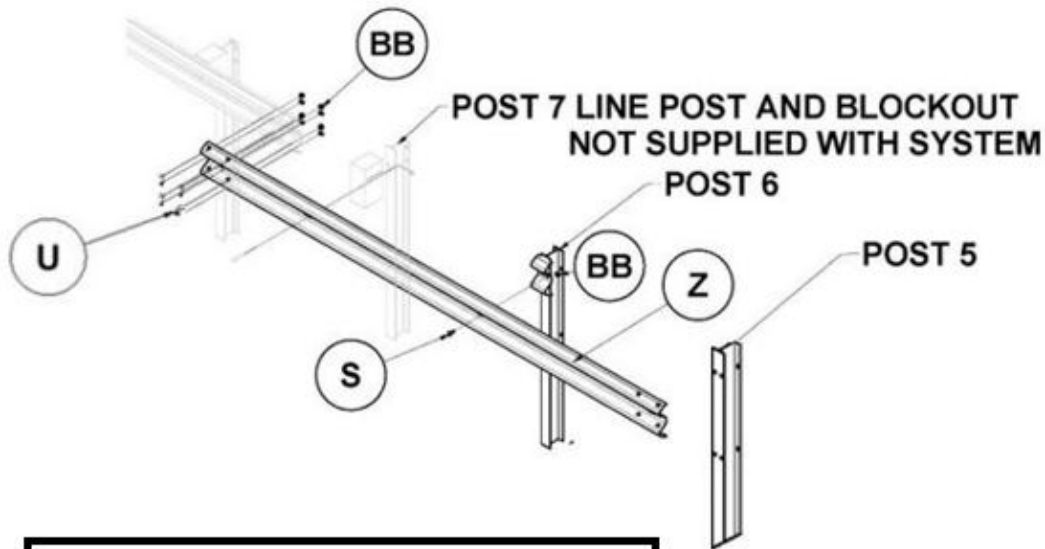

**Do NOT alter the lap orientation of the length-of-need guardrail when assembling a downstream/trailing end SRT™ 31 System.**

PARTS			INSTRUCTIONS
S	4419G	1 EA	<b>Reference Drawing SS616</b> 1. Assemble the SRT™-3 Guardrail (Part Z) as shown above. 2. Ensure the rail panel is straight between Posts 7 and 5 and the height is 31" above grade. 3. Ensure any gap between the back of the SRT™-3 Guardrail and the face of the SYTP® or SRT™ flange protector does not exceed 2" [50 mm]. 4. <b>Ensure SRT™-3 Guardrail is lapped in the direction of traffic immediately adjacent to the SRT™ 31 installation.</b> 5. Ensure 5/8" x 1.75" countersunk HD bolt (Part S) is used to attach the SRT™-3 Guardrail to Post 6. 6. Tighten all threaded hardware to a snug position with a minimum of two (2) bolt threads protruding beyond the nut.
Z	20442G	1 EA	
U	3360G	8 EA	
BB	3340G	9 EA	

Use only Valtir parts that are specified herein for the SRT™ 31 System for assembling, maintaining, or repairing the SRT™ 31 System. Do not utilize or otherwise commingle parts from other systems even if those systems are Valtir systems.

### WARNINGS

Do not attach the SRT™-3 Guardrail to post 5. Do not place anything between the post bolt head and the SRT™ 31 System Anchor Guardrail that would prevent the bolt from pulling through (i.e. no rectangular washer or delineator). Ensure the SRT™-3 Guardrail is straight between posts 7 and 5. Failure to follow this warning could result in serious injury or death in the event of a vehicle impact with the system.

# STEP 8

## SRT™ 31 Systems SRT™-2 Guardrail Assembly

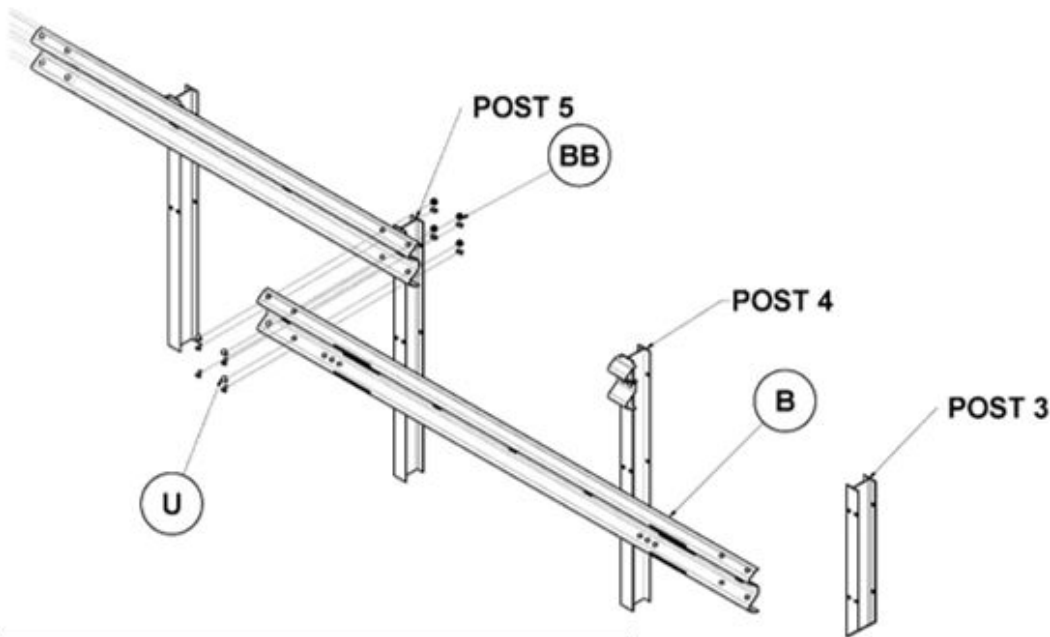

**Do NOT alter the lap orientation of the length-of-need guardrail when assembling a downstream/trailing end SRT™ 31 System.**

PARTS			INSTRUCTIONS
B	39G	1 EA	<ol style="list-style-type: none"> <li>1. Assemble the SRT™-2 Guardrail (Part B) as shown above.</li> <li>2. Ensure the SRT™-3 Guardrail and SRT™-2 Guardrail are straight between Posts 7 and 3 and the height is 31" above grade.</li> <li>3. Ensure any gap between the back of the SRT™ Anchor Guardrail and the face of the SYTP® or SRT™ Flange Protector does not exceed 2" [50mm].</li> <li>4. <b>Ensure SRT™-2 Guardrail is lapped in the direction of traffic immediately adjacent to the SRT™ 31 installation.</b></li> <li>5. Tighten all threaded hardware to a snug position with a minimum of two (2) bolt threads protruding beyond the nut.</li> </ol>
U	3360G	8 EA	
BB	3340G	8 EA	
<p>Use only Valtir parts that are specified herein for the SRT™ 31 System for assembling, maintaining, or repairing the SRT™ 31 System. <u>Do not utilize or otherwise commingle parts from other systems even if those systems are Valtir systems.</u></p>			WARNINGS
			<p>Do not attach the SRT™-2 Guardrail panel to post 5, 4 or 3. Ensure the SRT™-3 Guardrail and SRT™-2 Guardrail are straight between posts 7 and 3. Failure to follow this warning could result in serious injury or death in the event of a vehicle impact with the system.</p>

# STEP 9

## SRT™ 31 Systems SRT™-1 Anchor Guardrail Assembly

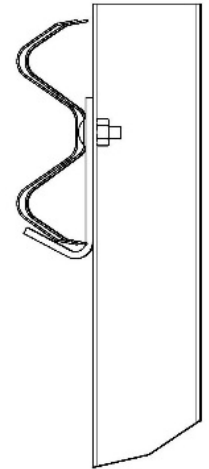
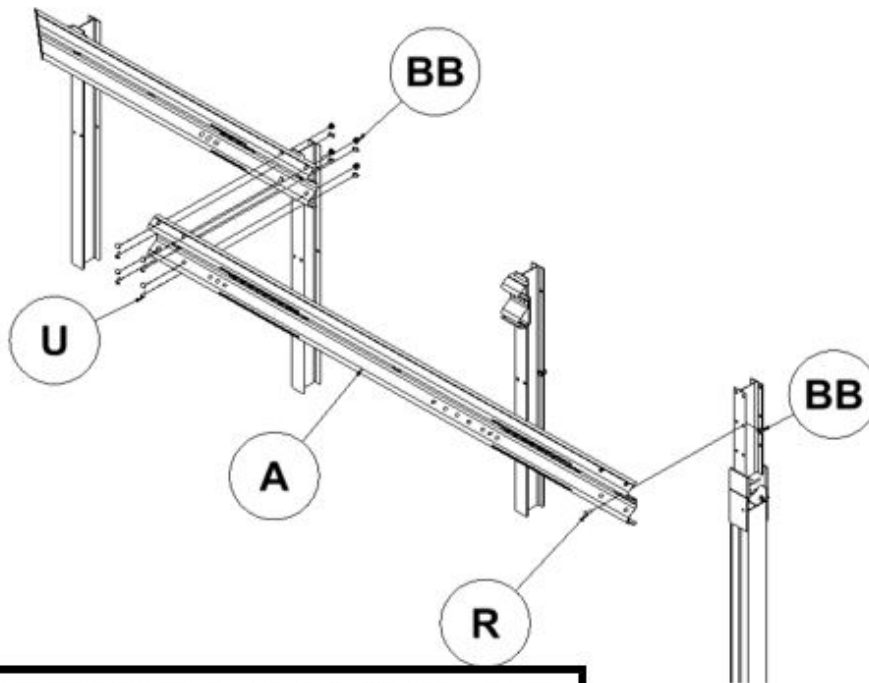

**Do NOT alter the lap orientation of the length-of-need guardrail when assembling a downstream/trailing end SRT™ 31 System.**

**POST 2 COMPLETED ASSEMBLY DETAIL**

PARTS			INSTRUCTIONS
A	30G	1 EA	<ol style="list-style-type: none"> <li>Assemble the SRT™-1 Anchor Guardrail (Part A) as shown above.</li> <li>Ensure the SRT™-1 Anchor Guardrail, SRT™-2 Guardrail and SRT™-3 Guardrail are straight between Posts 7 and 1 and the height is 31" above grade.</li> <li>Ensure any gap between the back of the SRT™ Anchor Guardrail and the face of the SYTP® or SRT™ Flange Protector does not exceed 2" [50mm].</li> <li>Ensure the SRT™-1 Anchor Guardrail and SRT™ Flange Protector are seated correctly <b>inside</b> the hook of the SRT™ Shelf Angle at Post 2. See <b>POST 2 COMPLETED ASSEMBLY DETAIL</b>.</li> <li><b>Ensure SRT™-1 Anchor Guardrail is lapped in the direction of traffic immediately adjacent to the SRT™ 31 installation.</b></li> <li>Tighten all threaded hardware to a snug position with a minimum of two (2) bolt threads protruding beyond the nut.</li> </ol>
R	3400G	1 EA	
U	3360G	8 EA	
BB	3340G	9 EA	
<p>Use only Valtir parts that are specified herein for the SRT™ 31 System for assembling, maintaining, or repairing the SRT™ 31 System. <u>Do not utilize or otherwise commingle parts from other systems even if those systems are Valtir systems.</u></p>			WARNINGS
			<p>Do not attach the SRT™-1 Anchor Guardrail panel to post 3 or 2. Ensure the SRT™ -1 Anchor Guardrail is seated correctly inside the hook of the SRT™ Shelf Angle as shown and is located on the traffic side of the post.</p>
			<p>Ensure the SRT™-1 Anchor Guardrail, SRT™-2 Guardrail and SRT™-3 Guardrail are straight between Posts 7 and 1. Failure to follow this warning could result in serious injury or death in the event of a vehicle impact with the system.</p>

# STEP 10

## SRT™ 31 Slot Guard Assembly

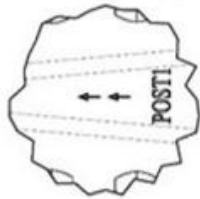

**DETAIL E**  
**ORIENTATION OF SRT™ SLOT GUARD**  
**POINTING TOWARD POST 1**

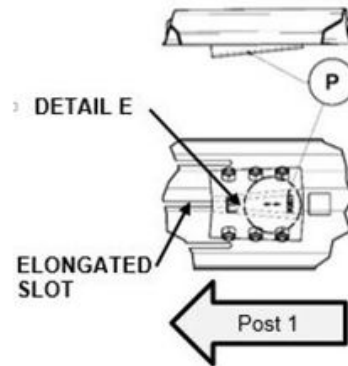

**SRT™ SLOT GUARD DETAIL**  
**NON-TRAFFIC SIDE**

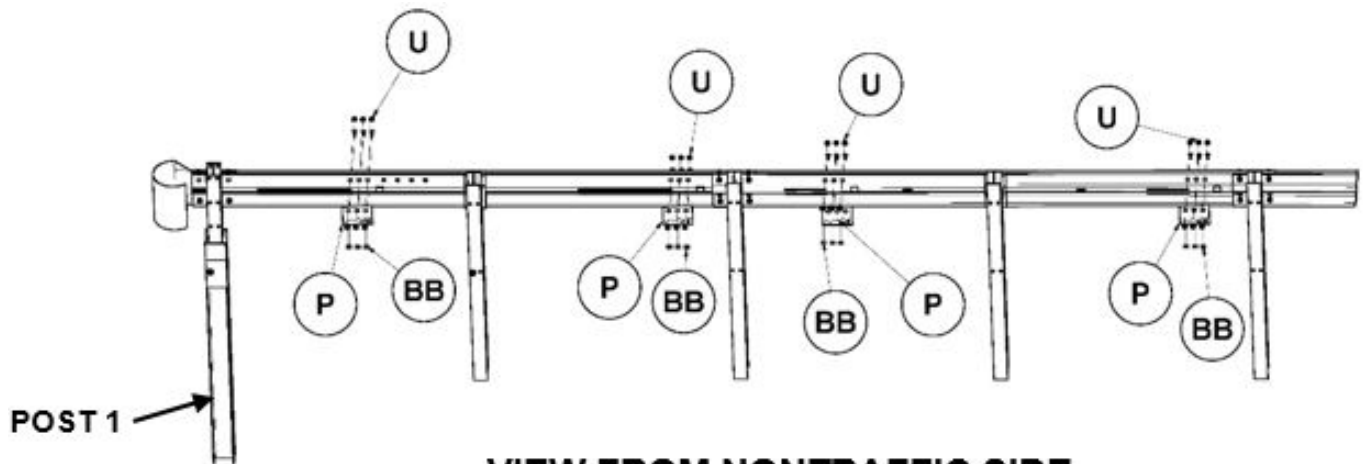

**VIEW FROM NONTRAFFIC SIDE**

PARTS			INSTRUCTIONS
P	9960G	4 EA	<ol style="list-style-type: none"> <li>1. Assemble the SRT™ Slot Guards (Part P) as shown above, with the arrow pointing toward Post 1.</li> <li>2. Ensure the SRT™ Slot Guards are assembled at the end of the elongated slots of the SRT™-1 Anchor Guardrails and SRT™-2 Guardrail away from Post 1.</li> <li>3. Place the SRT™ Slot Guards against the non-traffic side of the SRT™-1 Anchor Guardrail and SRT™-2 Guardrail with the deflector angle gap opening toward (closest to) the elongated slots.</li> <li>4. Insert all bolts from the traffic side, per the diagram.</li> <li>5. Assemble the nuts on non-traffic side of bolt.</li> <li>6. Tighten all threaded hardware to a snug position with a minimum of two (2) bolt threads protruding beyond the nut.</li> </ol>
U	3360G	24 EA	
BB	3340G	24 EA	

Use only Valtir parts that are specified herein for the SRT™ 31 System for assembling, maintaining, or repairing the SRT™ 31 System. Do not utilize or otherwise commingle parts from other systems even if those systems are Valtir systems.



### WARNINGS

Ensure the SRT™ Slot Guards are assembled as shown above. Failure to follow this warning could result in serious injury or death in the event of a vehicle impact with the system.

# STEP 11

## SRT™ Cable Anchor Bracket Assembly

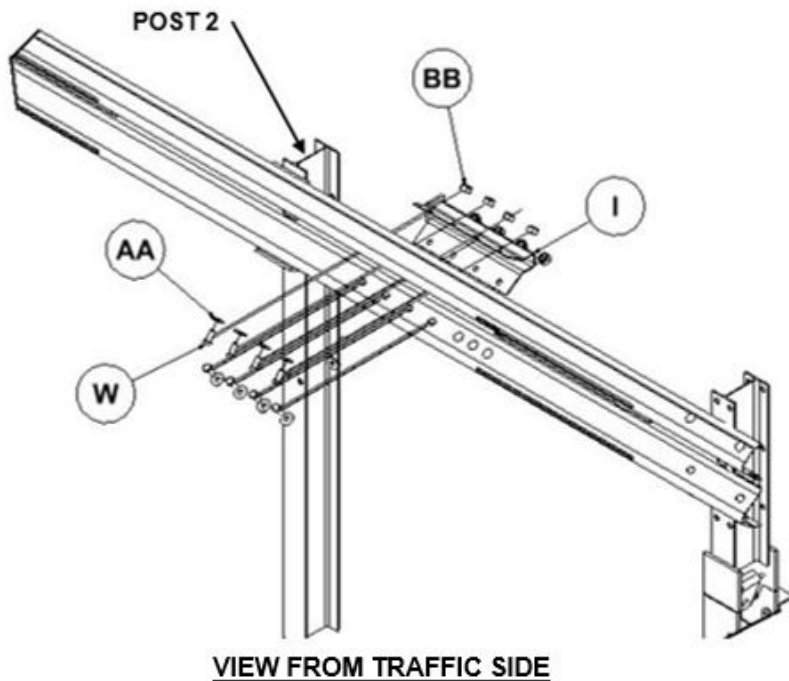

**VIEW FROM TRAFFIC SIDE**

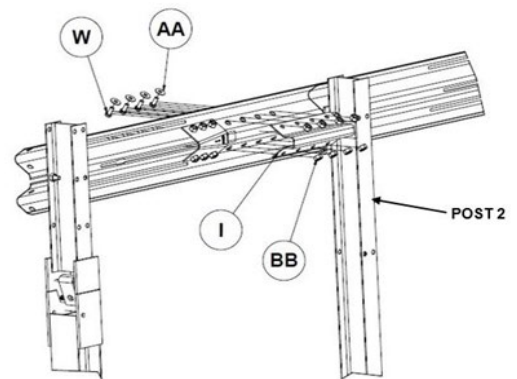

**VIEW FROM NONTRAFFIC SIDE**

PARTS			INSTRUCTIONS
I	700A	1 EA	<ol style="list-style-type: none"> <li>1. Assemble the SRT™ Cable Anchor Bracket (Part I) as shown above, with bracket on non-traffic side and welded plate towards Post 2.</li> <li>2. Ensure that flat washers (Part AA) are placed between the bolt head (Part W) and traffic side of the SRT™-1 Anchor Guardrail.</li> <li>3. Tighten all threaded hardware to a snug position with a minimum of two (2) bolt threads protruding beyond the nut.</li> </ol>
W	3380G	8 EA	
AA	3300G	8 EA	
BB	3340G	8 EA	
<p>Use only Valtir parts that are specified herein for the SRT™ 31 System for assembling, maintaining, or repairing the SRT™ 31 System. <u>Do not utilize or otherwise commingle parts from other systems even if those systems are Valtir systems.</u></p>			<p><b>WARNINGS</b></p> <div style="display: flex; align-items: center;">  <p>Ensure the SRT™ Cable Anchor Bracket is assembled as shown above. Failure to follow this warning could result in serious injury or death in the event of a vehicle impact with the system.</p> </div>

# STEP 12

## SRT™ Anchor Cable Assembly

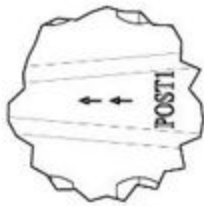

DETAIL E

**ORIENTATION OF SRT™ SLOT GUA!**  
POINTING TOWARD POST 1

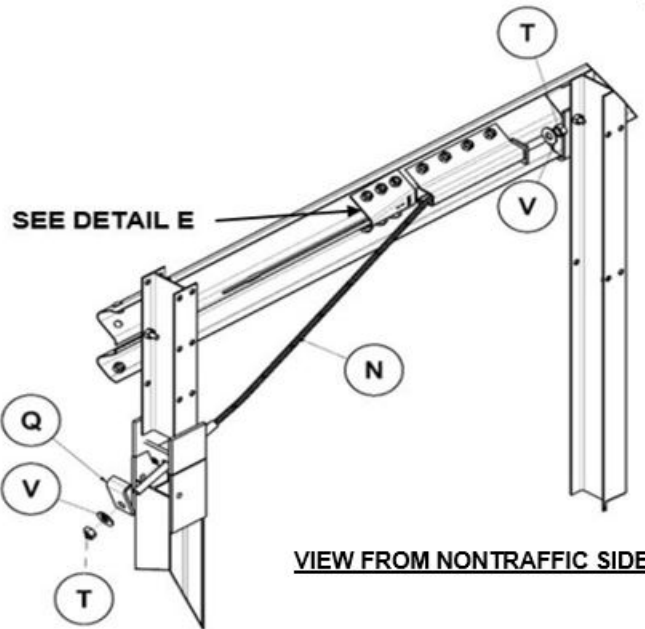



**VIEW FROM NONTRAFFIC SIDE**

PARTS			INSTRUCTIONS
N	3000G	1 EA	<ol style="list-style-type: none"> <li>1. Assemble the SRT™ Anchor Cable (Part N) as shown above.</li> <li>2. Ensure the bent part of the SRT™ Cable Anchor Bracket Angle (Part Q) at SRT™ Anchor Post is up and hooked over the CR Post 1 Top.</li> <li>3. While tightening nut with a wrench, restrain the cable with locking pliers at the end being tightened to avoid twisting the cable.</li> <li>4. Tighten the cable until it is taut. The cable is considered taut when it does not deflect more than 1 inch [25 mm] when pressure is applied by hand in an up or down direction.</li> </ol>
Q	33909G	1 EA	
T	3910G	2 EA	
V	3900G	2 EA	
<p>Use only Valtir parts that are specified herein for the SRT™ 31 System for assembling, maintaining, or repairing the SRT™ 31 System. <u>Do not utilize or otherwise commingle parts from other systems even if those systems are Valtir systems.</u></p>			WARNINGS
			<p>Ensure the cable is taut. Failure to follow this warning could result in serious injury or death in the event of a vehicle impact with the system.</p> <p>Ensure the bent part of the SRT™ Cable Anchor Bracket Angle at SRT™ Anchor Post is up and hooked over the CR Post 1 Top.</p>

# STEP 13

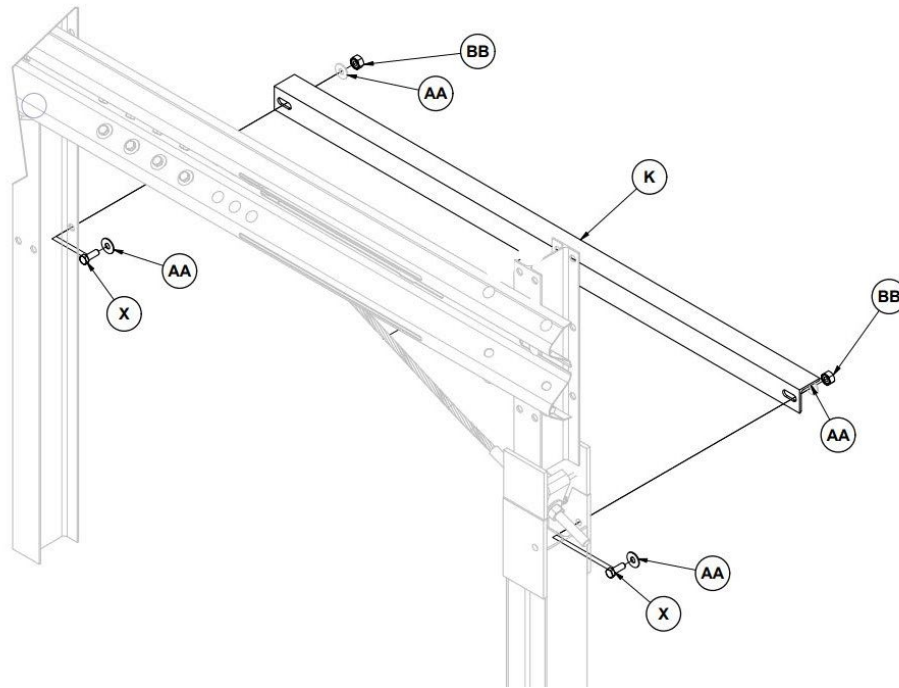
## SRT™ Angle Strut Assembly



PARTS			INSTRUCTIONS
K	33875G	1 EA	<ol style="list-style-type: none"> <li>1. Assemble the SRT™ Angle Strut (Part K) as shown above on the non-traffic side.</li> <li>2. In a relatively flat grade installation a portion of the SRT™ Angle Strut <u>will be slightly below grade</u>, the installer must provide a shallow valley/trough for installation of the strut between Post 1 and 2.</li> <li>3. Use the SYTP® hole in Post #2 that best aligns with the SRT™ Angle Strut.</li> <li>4. Tighten all threaded hardware to a snug position with a minimum of two (2) bolt threads protruding beyond the nut.</li> </ol>
X	3391G	2 EA	
AA	3300G	4 EA	
BB	3340G	2 EA	
<p>Use only Valtir parts that are specified herein for the SRT™ 31 System for assembling, maintaining, or repairing the SRT™ 31 System. <u>Do not utilize or otherwise commingle parts from other systems even if those systems are Valtir systems.</u></p>			WARNINGS
			<p>Ensure the SRT™ Angle Strut is properly attached to the CR Post 1 Bottom and SYTP® on the non- traffic side.</p>

# STEP 14

## SRT™ Buffer Assembly

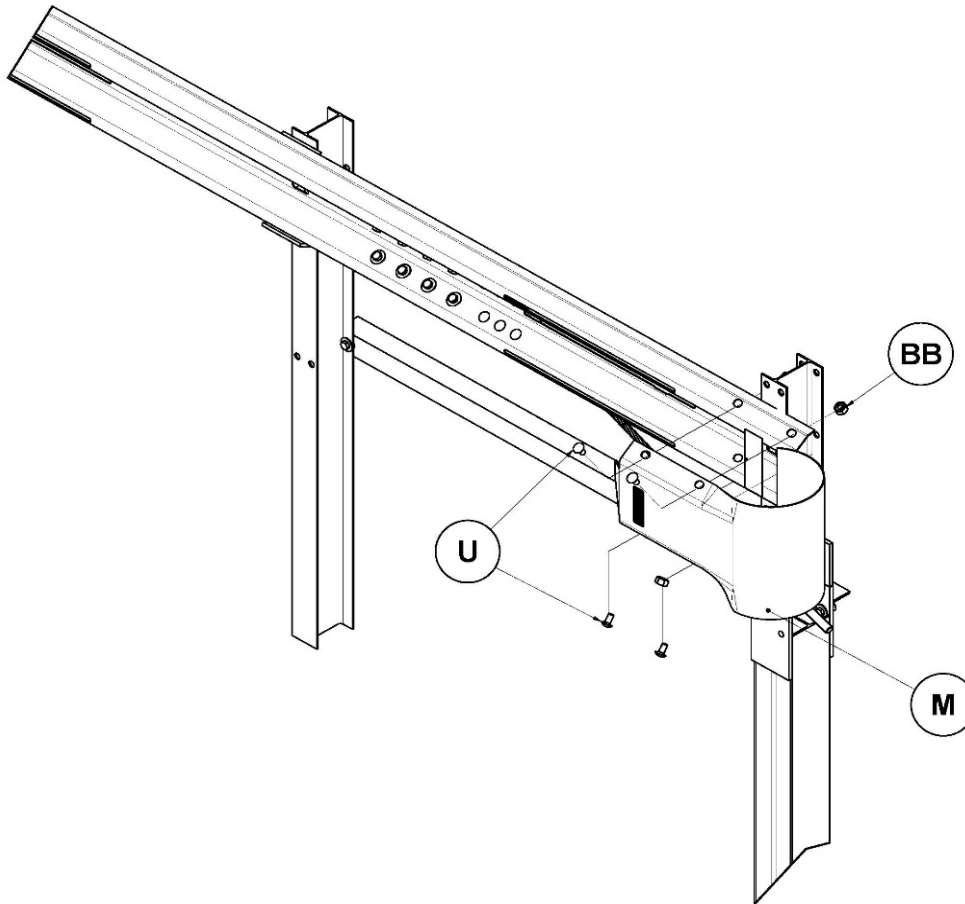

PARTS			INSTRUCTIONS
M	907A	1 EA	1. Assemble the SRT™ Buffer (Part M) as shown above. 2. Tighten all threaded hardware to a snug position with a minimum of two (2) bolt threads protruding beyond the nut.
U	3360G	4 EA	
BB	3340G	4 EA	

Use only Valtir parts that are specified herein for the SRT™ 31 System for assembling, maintaining, or repairing the SRT™ 31 System. Do not utilize or otherwise commingle parts from other systems even if those systems are Valtir systems.

### WARNINGS





Ensure the SRT™ Buffer is located on the traffic side and outside of the SRT™-1 Anchor Guardrail.

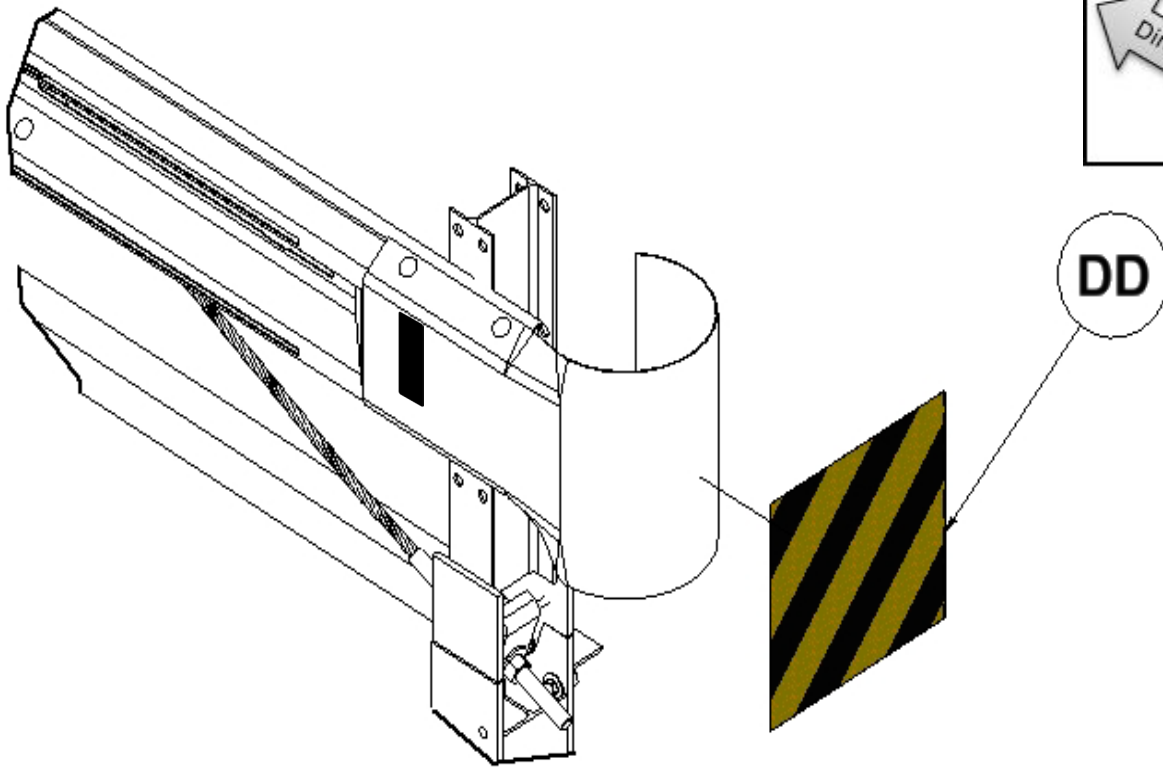

# STEP 15

## SRT™ 31 System Delineation



PARTS			INSTRUCTIONS
DD	6665B	1 EA	<p>1. Attach the Delineation Sheeting as shown above. Yellow and Black (Part DD) shown; Solid Yellow (Part EE) available.</p> <p><b>Note:</b> Manufacturer suggests that user provide delineation (reflective sheeting) as required by the state/specifying agency for terminals.</p> <p>1. <b>Note:</b> Valtir offers two (2) specific reflective sheeting: (Yellow/Black (6665B) and Solid Yellow (6666B). Both options can be used for right or left hand assembly applications. Valtir makes no guarantees they meet the minimum specifications, comply with MUTCD requirements or comply with state/specifying agency requirements.</p>
EE	6666B	1 EA	
<p>Use only Valtir parts that are specified herein for the SRT™ 31 System for assembling, maintaining, or repairing the SRT™ 31 System. <u>Do not utilize or otherwise commingle parts from other systems even if those systems are Valtir systems.</u></p>			WARNINGS
			 <p>Ensure delineation (reflective sheeting) used on the SRT™31 System meets state/specifying agency or MUTCD for proper delineation. Use of steel delineator posts must be a minimum of 3'-0" [1 m] in front (upstream) of the SRT™ 31 System</p>

# **SRT™ 31 System Assembly Checklist**

## **(File With Project Records)**

Performed by: \_\_\_\_\_

Date: \_\_\_\_\_

Location: \_\_\_\_\_

- 1. Ensure only Valtir SRT™ 31 System parts are used for the assembly of the SRT™ 31 System and that all parts are free of damage. (p 5)
- 2. Ensure required traffic control is in place to conduct SRT™ 31 System assembly. (p 5)
- 3. Ensure proper site grading complies with state/specifying agency guidelines or AASHTO Roadside Design Guide, whichever is more stringent. (pp 13 & 36)
- 4. Ensure SRT™ 31 System has a 4'0" [1.22 m] straight-line offset.(pp 15-16)
- 5. Ensure the center of the SYTP® yielding holes are approximately centered at finished grade line for posts 2 - 6. (p 17)
- 6. Ensure that soil around all SYTP® is properly compacted and post will be free to rotate. When leave-outs are necessary, use only state/specifying agency's approved backfill material within the leave-out area. (pp 14 & 37)
- 7. Ensure the CR Post 1 top and CR Post 1 bottom are oriented correctly. (p 20)
- 8. Ensure the top of the CR Post 1 Bottom does not protrude more than 4" [100 mm] above the finished grade. (p 19)
- 9. Ensure the SRT™ Shelf Angle at Post 2 is attached with 2 bolts and the SRT™ Flange Protector and SRT™ Anchor Guardrail are placed appropriately. (p 21)
- 10. Ensure that the SRT™-1 Anchor Guardrail and SRT™ -2 and -3 Guardrails height are approximately 31" [787 mm] above the finished grade. (pp 6-7 & 23- 26)
- 11. Ensure the SRT™ Flange Protector is installed on traffic side of post 4. (p 22)
- 12. Ensure the SRT™-1 Anchor Guardrail and SRT™ -2 and -3 Guardrails between Posts 1 and 7 are not curved. (pp 23- 26)
- 13. Ensure the SRT™-1 Anchor Guardrail and SRT™ -2 and -3 Guardrails are oriented correctly and lapped in the direction of the nearest adjacent traffic. (p 23)
- 14. Ensure that the SRT™ -2 and -3 Guardrails are not bolted to posts 2-5. (pp 24-26)
- 15. Ensure 5/8" x 1.75" countersunk HD bolt is used to attach the SRT™-3 Guardrail to Post 6. (p 24)
- 16. Ensure the SRT™ Slot Guards are in place against the non-traffic side of the SRT™ -1 Anchor Guardrail and SRT™ -2 and -3 Guardrail with the deflector angle gap opening toward (closest to) the elongated slot and arrows pointing towards Post 1. (p 27)
- 17. Ensure the SRT™ Cable Anchor Bracket is placed between Posts 1 and 2 on the non-traffic side of the SRT™-1 Anchor Guardrail and the SRT™ Cable Anchor Bracket is bolted to the SRT™-1 Anchor Guardrail with eight (8) Hex Bolts and that washers are placed between the bolt head and the front of the SRT™-1 Anchor Guardrail. (p 28)
- 18. Ensure the bent part of the SRT™ Cable Anchor Bracket Angle [Part Q] at SRT™ Anchor Post is up and hooked over the CR Post 1 Top. (p 28-29)
- 19. Ensure washers are ONLY used on the traffic side of the SRT™-1 Anchor Guardrail for the SRT™ Cable Anchor Bracket. (p 28)
- 20. Ensure the 1" Hex Nuts have been fully tightened and the SRT™ Anchor Cable is taut. (p 29)
- 21. Ensure the SRT™ Angle Strut is properly attached on the non-traffic side to the CR Post 1 Bottom and Post 2 SYTP®. (p 30)
- 22. Ensure that all fasteners of the SRT™ 31 System are tightened to a snug position with a minimum of two (2) bolt threads protruding beyond the nut. (Various pp)
- 23. Ensure delineation is placed on the SRT™ Buffer per MUTCD and/ or state/specifying agency. (p 32)
- 24. Ensure any steel delineator posts are a minimum of 3' [1 m] upstream from the SRT™ Buffer. (p 32)

# **SRT™ 31 System Repair Checklist** **(File With Maintenance Records)**

Performed by: \_\_\_\_\_

Date: \_\_\_\_\_

Location: \_\_\_\_\_

- 1. Ensure only Valtir SRT™ 31 System parts are used for the assembly of the SRT™ 31 System and that all parts are free of damage. (p 5)
- 2. Ensure required traffic control is in place to conduct SRT™ 31 System assembly. (p 5)
- 3. Ensure proper site grading complies with state/specifying agency guidelines or AASHTO Roadside Design Guide, whichever is more stringent. (pp 13 & 36)
- 4. Ensure SRT™ 31 System has a 4'0" [1.22 m] straight-line offset.(pp 15-16)
- 5. Ensure the center of the SYTP® yielding holes are approximately centered at finished grade line for posts 2 - 6. (p 17)
- 6. Ensure that soil around all SYTP® is properly compacted and post will be free to rotate. When leave-outs are necessary, use only state/specifying agency's approved backfill material within the leave-out area. (pp 14 & 37)
- 7. Ensure the CR Post 1 top and CR Post 1 bottom are oriented correctly. (p 20)
- 8. Ensure the top of the CR Post 1 Bottom does not protrude more than 4" [100 mm] above the finished grade. (p 19)
- 9. Ensure the SRT™ Shelf Angle at Post 2 is attached with 2 bolts and the SRT™ Flange Protector and SRT™ Anchor Guardrail are placed appropriately. (p 21)
- 10. Ensure that the SRT™-1 Anchor Guardrail and SRT™ -2 and -3 Guardrails height are approximately 31" [787 mm] above the finished grade. (pp 6-7 & 23- 26)
- 11. Ensure the SRT™ Flange Protector is installed on traffic side of post 4. (p 22)
- 12. Ensure the SRT™-1 Anchor Guardrail and SRT™ -2 and -3 Guardrails between Posts 1 and 7 are not curved. (pp 23- 26)
- 13. Ensure the SRT™-1 Anchor Guardrail and SRT™ -2 and -3 Guardrails are oriented correctly and lapped in the direction of the nearest adjacent traffic. (p 23)
- 14. Ensure that the SRT™ -2 and -3 Guardrails are not bolted to posts 2-5. (pp 24-26)
- 15. Ensure 5/8" x 1.75" countersunk HD bolt is used to attach the SRT™-3 Guardrail to Post 6. (p24)
- 16. Ensure the SRT™ Slot Guards are in place against the non-traffic side of the SRT™ Anchor Guardrail and SRT™ -2 and -3 Guardrail with the deflector angle gap opening toward (closest to) the elongated slot and arrows pointing towards Post 1. (p 27)
- 17. Ensure the SRT™ Cable Anchor Bracket is placed between Posts 1 and 2 on the non-traffic side of the SRT™-1 Anchor Guardrail and the SRT™ Cable Anchor Bracket is bolted to the SRT™-1 Anchor Guardrail with eight (8) Hex Bolts and that washers are placed between the bolt head and the front of the SRT™-1 Anchor Guardrail. (p 28)
- 18. Ensure the bent part of the SRT™ Cable Anchor Bracket Angle [Part Q] at SRT™ Anchor Post is up and hooked over the CR Post 1 Top. (p 28-29)
- 19. Ensure washers are ONLY used on the traffic side of the SRT™-1 Anchor Guardrail for the SRT™ Cable Anchor Bracket. (p 28)
- 20. Ensure the 1" Hex Nuts have been fully tightened and the SRT™ Anchor Cable is taut. (p 29)
- 21. Ensure the SRT™ Angle Strut is properly attached on the non-traffic side to the CR Post 1 Bottom and Post 2 SYTP®. (p 30)
- 22. Ensure that all fasteners of the SRT™ 31 System are tightened to a snug position with a minimum of two (2) bolt threads protruding beyond the nut. (Various pp)
- 23. Ensure delineation is placed on the SRT™ Buffer per MUTCD and/ or state/specifying agency. (p 32)
- 24. Ensure any steel delineator posts are a minimum of 3' [1 m] upstream from the SRT™ Buffer. (p 32)

# **SRT™ 31 Routine Inspection Checklist**

## **(File with Maintenance Records)**

Performed by: \_\_\_\_\_

Date: \_\_\_\_\_

Location: \_\_\_\_\_

Valtir recommends the state/specifying agency develop and administer their own end terminal inspection program, based on location of unit, volume of traffic and impact history.



**Important: The SRT™ 31 System and all of its components shall be inspected for damage after every impact. Repair using only Valtir parts that are specified for use within this SRT™ 31 System Product Description Assembly Manual.**

If no end terminal inspection program exists, Valtir recommends visual drive-by inspections at least once every month and walk-up inspections every six (6) months. These inspections shall, at a minimum, consist of:

### **Visual Drive-By Inspections (Recommended Frequency: Monthly)**

- Check for damage caused by vehicle impacts.
- Check for damage caused by impacts from snowplow, mowing or roadway operations.
- Check for misalignment.
- Check for missing system components.
- Check for vandalism.
- Check for damage caused by adverse weather conditions (i.e. erosion, weight of snow, UV).

### **Walk-Up Inspections (Recommended Frequency: Every Six (6) Months)**

Walk-Up Inspections include ALL Visual Drive-By Inspection items (listed above) as well as the items listed below.

- Ensure required traffic control is in place to conduct walk-up inspection.
- Clear and dispose of any debris or trash found on the SRT™ 31 System site, which may interfere with the performance of the SRT™ 31 System.
- Check that fasteners are fully tightened and a minimum of two (2) bolt threads are protruding beyond the nut.
- Check for erosion to the site grading around the system.
- Ensure that the SRT™ Anchor Cable is taut and the SRT™ Cable Anchor Bracket Angle is properly positioned.

If any of the above items are identified during the inspection process, swift action shall be taken to correct and repair the SRT™ 31 System to working condition as outlined in the SRT™ 31 System Product Description Assembly Manual, latest edition.

# Appendix A

## AASHTO Roadside Design Guide Grading Detail

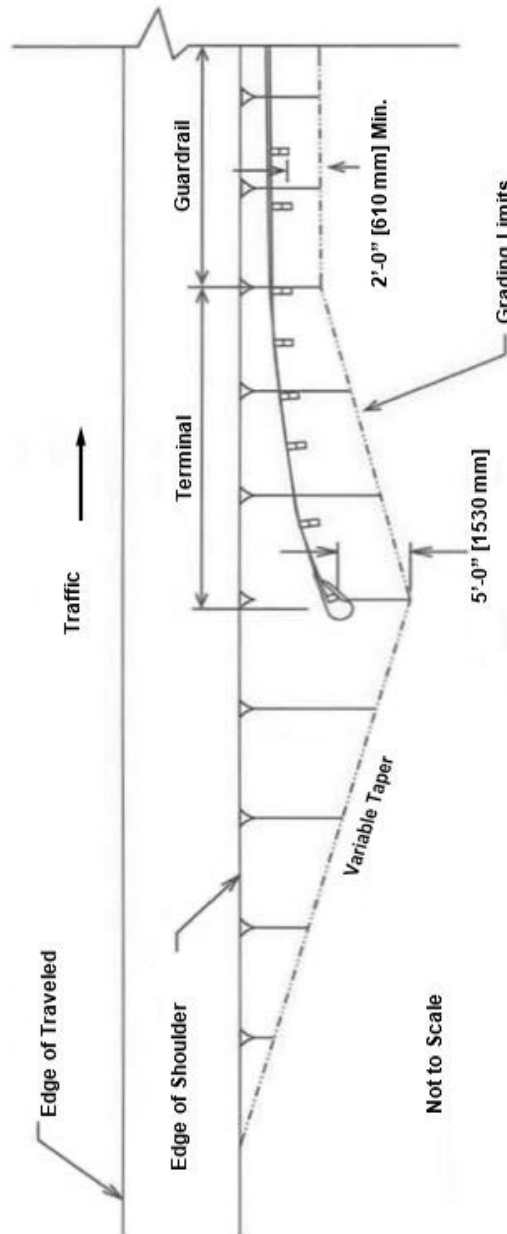

Drawing Source: AASHTO Roadside Design Guide, 4<sup>th</sup> Edition 2011



**Important: Valtir does not direct grading.** Proper site grading must be accomplished before assembly of the SRT™ 31 System in accordance with state/specifying agency guidelines OR the AASHTO Roadside Design Guide whichever is more stringent. Failure to follow this warning could result in serious injury or death in the event of a vehicle impact with the system.

# Appendix B

## Leave-Outs

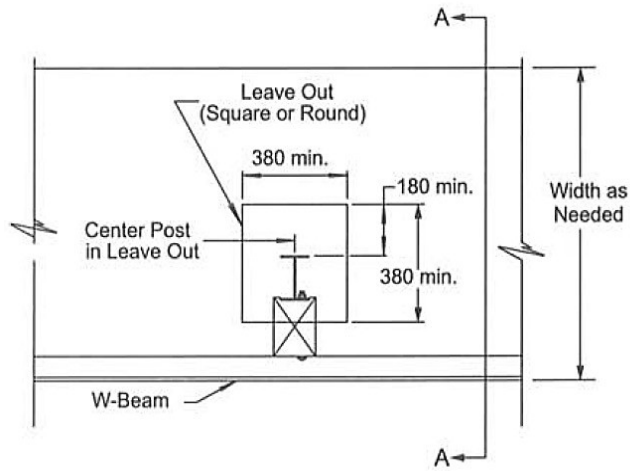

Steel Post Detail (Metric)

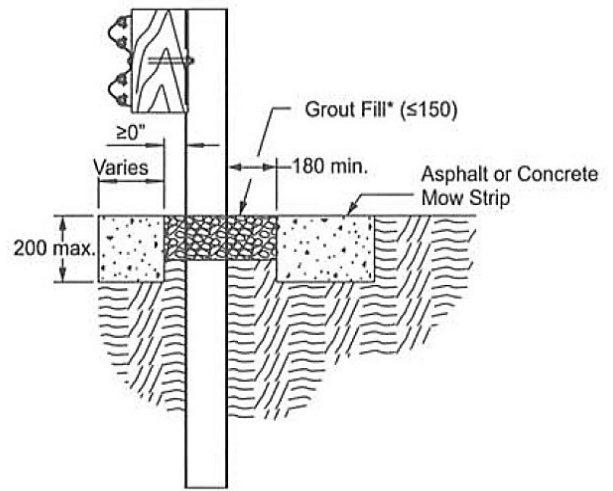

Section A-A

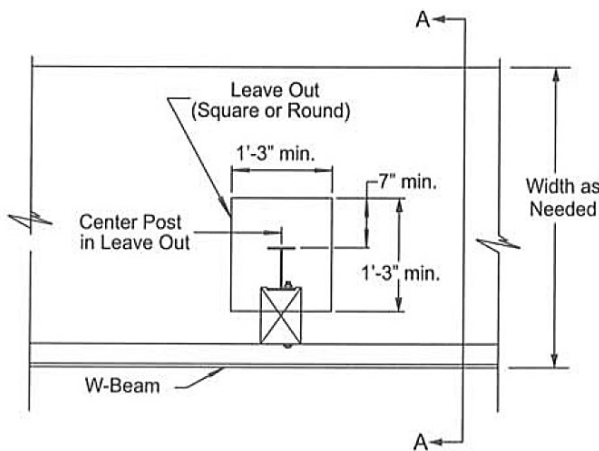

Steel Post Detail

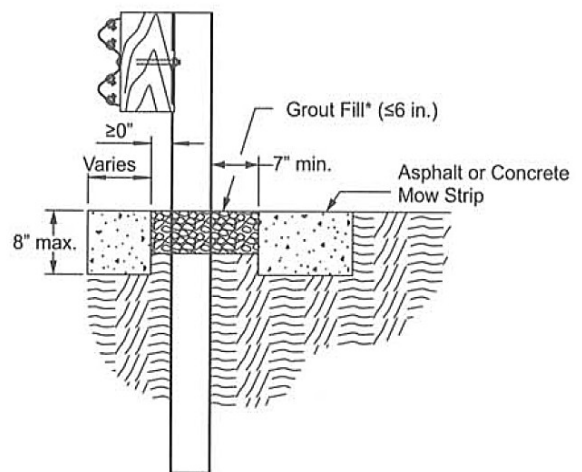

Section A-A

\*Grout fill material must have a 28-day compressive strength of 120 psi [0.85 MPa] or less.

Drawing Source: AASHTO Roadside Design Guide, 4<sup>th</sup> Edition 2011



**WARNING:** Ensure a proper leave out area (the specified size of open space as defined in the AASHTO Roadside Design Guide) is provided around the post(s) and filled with state/specifying agency approved backfill material that will not prevent movement, for any posts installed in rigid pavement such as any thickness of concrete or asphalt. Failure to follow this warning could result in serious injury or death in the event of a vehicle impact with the system.

# Appendix C

## Encountering Rock

Complete the following steps to install CR Post 1 Bottom and SYTP® when encountering rock.

If compactable, the material removed from the hole may be used for the backfill.

### CR POST



**The CR Post 1 Bottom must be installed full depth,**

Complete the following steps to install CR Post 1 Bottom:

1. Drill a 9"-12" [225 mm-300 mm] diameter hole into the rock for a full length installation of the CR Post 1 Bottom.
2. Insert the CR 1 Bottom post into the hole. See Step 3 for CR Bottom Post 1 Bottom orientation.
3. Ensure the ears of the CR Post 1 Bottom will not protrude more than 4" [100 mm] above the finished grade.
4. Backfill the hole with material in 6" [150 mm] lifts and compact to optimum compaction.

### SYTP®

Select Case A or Case B unless there is a more restrictive state/specifying agency specification.

**NOTE: For Case A, the post must be embedded a minimum of 24" [600 mm] into the rock.**

#### Case A

If rock is encountered **within a depth of 16" [400 mm] from the finished grade**, complete the following steps to install the SYTP® Post:

1. Drill a 21"-24" [525 mm-600 mm] diameter hole a minimum 24" [600 mm] deep into the rock.
2. A portion of the SYTP® will have to be removed. The amount to be cut off from the bottom of the SYTP® is determined by measuring from the finished grade to the bottom of the hole and subtracting that measurement from 40" [1000 mm]. The difference is the amount to be cut off.
3. Insert the cut off SYTP® into the hole.
4. Ensure the center of the SYTP® yielding holes are approximately at the finished grade.
5. Backfill the hole with material in 6" [150 mm] lifts and compact to optimum compaction.
6. Ensure SRT™ 31 System Anchor Guardrail height is approximately 31" [787 mm] above the finished grade.

#### Case B

If rock is encountered at a depth **greater than 16" [400 mm] from the finished grade**, complete the following steps to install the SYTP®:

1. Drill an 8"-12" [200 mm-300 mm] diameter hole into the rock so the full length SYTP® can be installed in the hole.
2. Install the SYTP® into the hole.
3. Ensure the center of the SYTP® yielding holes are approximately at the finished grade.
4. Backfill the hole with material in 6" [150 mm] lifts and compact to optimum compaction.
5. Ensure the SRT™ 31 System Anchor Guardrail height is approximately 31" [787 mm] above the finished grade.









For more complete information on Valtir products and services, visit us on the web at [www.valtir.com](http://www.valtir.com). Materials and specifications are subject to change without notice. Please contact Valtir to confirm that you are referring to the most current instructions.

**WWW.VALTIR.COM**  
**1.888.356.2363**