

SRT™ / HBA™ 6-POST SYSTEM

INSTALLATION, MAINTENANCE, AND REPAIR MANUAL

SRT™/ HBA™ 6-POST SYSTEM

FOR SPECIFIC DETAILS, REFER TO THE
STATE STANDARD DRAWING

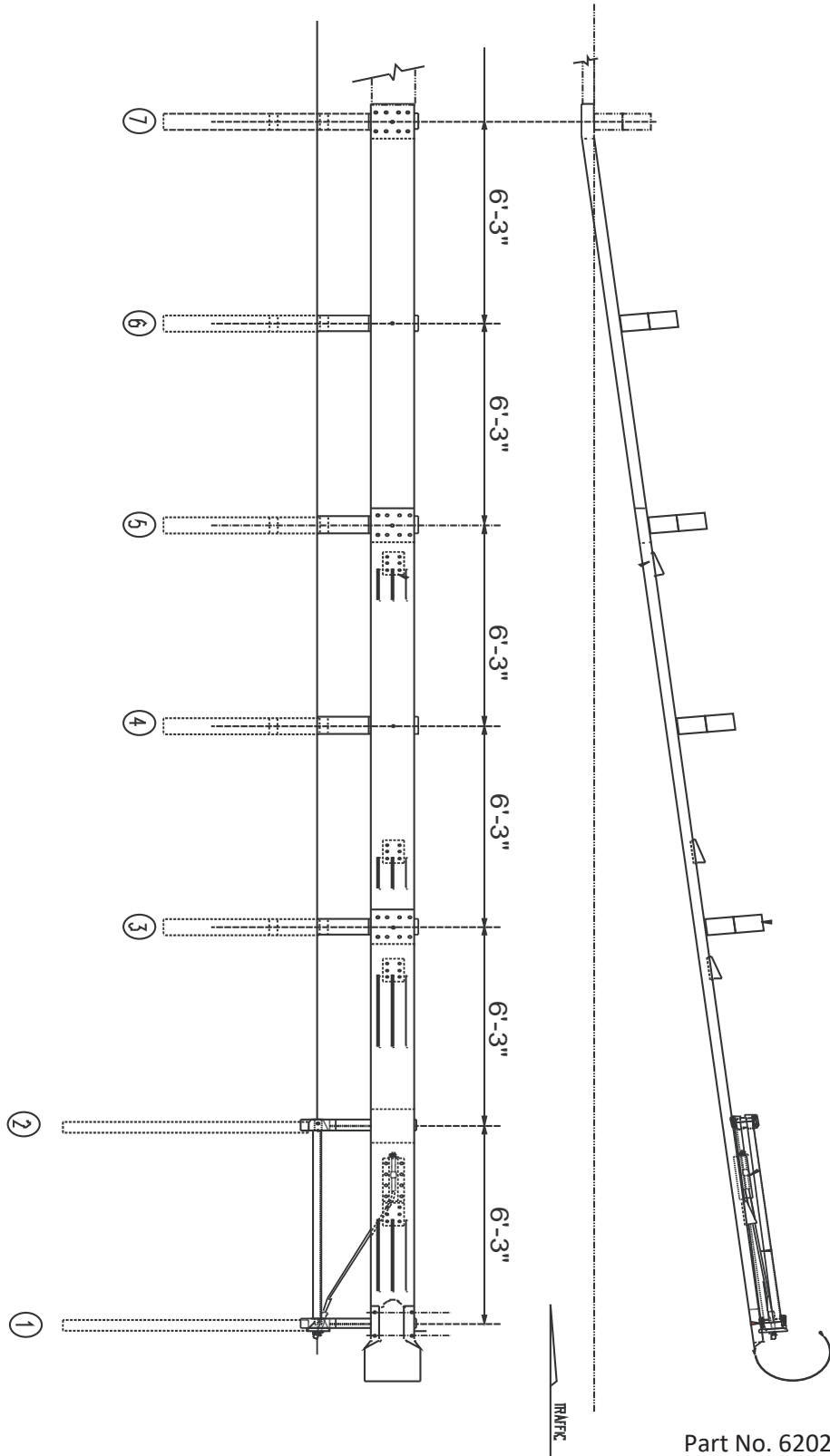

SRT™ / HBA™ 6-POST SYSTEM BILL OF MATERIAL ENGLISH (METRIC)

(FOR QUANTITIES, SEE STATES OPTION(S))

PC	QTY	DESCRIPTION
3G	1	12/12"/ BACKUP (2.67/0.305) GUARDRAIL
9G	1	12/12.5'/6'3"/S (2.67/3.81/1.905/S) GUARDRAIL
30G	1	12/12.5'/6'3"/S (2.67/3.81/1.905/S) SRT-1 ANC GUARDRAIL
39G	1	12/12.5'/6'3"/S (2.67/3.81/1.905/S) SR 2 GUARDRAIL
700A	1	CABLE ANCHOR BRACKET
907G	1	12 (2.67)/BUFFER/ROLLED (TERMINAL)
3000G	1	CABLE ASSEMBLY 3/4" x 6'6" (19 x 1981)
3300G	14	5/8" (16) WASHER
3340G	58	5/8" (16) HGR NUT
3360G	44	5/8" DIA. x 1 1/4" (16 DIA x 35) HGR SPLICE BOLT
3380G	8	5/8" DIA. x 1 1/2" (16 DIA. x 38) HEX HEAD BOLT
3400G	2	5/8" DIA x 2" (16 DIA. x 50) POST BOLT
3580G	4	5/8" DIA x 18" (16 DIA x 460) HGR POST BOLT
3701G	10	3/4" (19) WASHER
3704G	4	3/4" (19) HEX NUT
3718G	4	3/4" DIA X 3 "(19 DIA.x 75) HIGH STRENGTH HEX HEAD BOLT
3900G	1	1" (25) WASHER
3910G	1	1" (25) HEX NUT
4063B	4	WOODPOST 6" x 8" x 6'0" (150 x 200 X 1830)
4075B	4	WOODBLOCK 6" x 8" x 14" (150 x 200 x 360) DR
4254G	5	3/8" (10) WASHER
4258G	4	3/8" (10) LOCKWASHER
4261G	1	3/8" x 1 1/2" (10 DIA. x 38) HEX HEAD BOLT (GR 5)
4699G	4	3/4" (19) LOCKWASHER
6321G	4	3/8" DIA. X 2 " (10 DIA x 50) HEX HEAD BOLT (GR 5)
6405G	5	3/8" (10) HEX NUT
9960G	4	SLOT GUARD
9961G	1	3/8" x 3" x 4" (10 x 75 x 100) PLATE WASHER
33876A	1	HBA POST 1 TOP (W6 x 8.5)
33877A	1	HBA POST 2 TOP (W6 x 8.5)
33878A	2	HBA POST 1 & 2 BOT (TS 6 x 4)
33879G	2	ANGLE STRUT 2" X 2" X 3/8" (50 x 50 x 10)
33880G	1	1" x 6" x 8" (25 x 150 x 200) BEARING PLATE
33881G	1	CABLE WEB PL 4" x 1/4" x 5 3/4" (100 x 6 x 146)

DELINEATION OPTIONS

6665B	1	STRIPED (YELLOW/BLACK) REFLECTOR 16" x 16" (400 x 400)
-------	---	--

INSTALLING THE SRT™ / HBA™ 6-POST SYSTEM

Valtir drawings for the SRT should be used with these instructions. The states standard drawings for this system need to be reviewed for details that will be specific to that state.

The SRT™/HBA™ Post System has a straight flare; the earlier versions of the SRT-350™ used a parabolic (curved) flare. At posts one and two, HBA™ posts are used in place of the soil tubes and wood posts. The same equipment and expertise is required for both systems. Anyone with experience installing the SRT-350™ should have no difficulty installing the SRT™/HBA™ Post System.

MATERIALS

As packaged, the SRT™/HBA™ Post System includes all materials needed for the installation.

Note that concrete footings or foundations are not required.

TOOLS REQUIRED

Tools required are those ordinarily used to install standard highway guardrail (HGR). They include 9/16", 15/16", 1-1/4" and 1-1/2" sockets and wrenches and such other equipment as augers and post pounders commonly used in driving posts.

SITE PREPARATION

Site grading is usually necessary for the proper placement of the HBA™ posts and the Controlled Release Terminal (CRT) posts. It is suggested that this grading be completed before the start of the installation of the SRT™/HBA™.

INSTALLATION

Be sure adequate time is allowed for "same day" complete installation.

If special field conditions are encountered when installing the SRT™/HBA™ Post System, contact Valtir @ (888) 356-2363 to review the conditions.

POST LAYOUT

The SRT™/HBA™ Post System is a 37'6" (11.43 m) that utilizes a straight flare. Start at the end (post location 7) of the guardrail run and measure along the flared system a distance of 37'6" (11.43 m). At this point, measure an offset of 4'0" (1.21 m) perpendicular to the road. This establishes the face location of post no. 1. A straight line between post no. 1 and face of the blockout of post no. 7 establishes the location of either the face of the post or the face of the blockout for each of the posts. All posts are spaced at 6'3" (1905 mm) on center.

INSTALLING THE CRT POSTS

Install the wood posts at locations 6 thru 3. These posts (PC-4063B) may be driven. They may also be installed by drilling holes approximately 44" (1120 mm) deep. Insert the 6'0" (1830 mm) wood post into these holes and backfill. Note that in either case, the bottom of the upper 3 1/2" (90 mm) hole in the post is approximately at finished grade. **See Figure 1.** Posts 3 thru 7 are spaced at 6'3" (1905 mm) intervals.

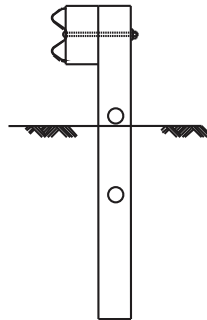

FIGURE1

INSTALLING HBA™ BOTTOM POSTS

There are two methods for the installing the HBA™ bottom posts at locations 1 and 2. The posts should be oriented so that the larger hole (13/16" (21 mm)) is placed downstream (away from the end of the system).

METHOD A Drive the HBA Bottom Posts (PC-33878A) with an approved driving head to the appropriate depths, approximately 72"(1830 mm). The optimum depth will have the bottom of the 13/16" (21 mm) holes in the ears even with the finished grade.

METHOD B Drill a 12" (300 mm) pilot hole approximately 72" (1830 mm) deep and Install the HBA Bottom Posts to the appropriate depth. The optimum depth will have the bottom of the 13/16" (21 mm) holes in the ears even with the finished grade.

If **METHOD B** is used, material should be placed in 6" (150 mm) lifts and compacted with pneumatic equipment to optimum compaction.

INSTALLING HBA™ POSTS WHEN ENCOUNTERING ROCK

If rock is encountered when installing the HBA posts, use the following procedures, unless there is a more restrictive state specification.

If rock is encountered and 20" (510 mm) or less depth is required to complete the installation of the bottom HBA post, drill a 12"-16" (300 mm - 400 mm) diameter hole in the rock. The hole should be drilled 2" (50 mm) deeper than required embedment depth. Place in the bottom 2 inches (50 mm) of the hole for drainage granular material

or small pieces of the drilled rock. Backfill and compact the hole after installing the HBA™ post. If compactable, the material removed from the hole may be used for the backfill.

If rock is encountered and more than 20" (510 mm) depth is required to install the bottom HBA post, drill a 12"-16" (300 mm-400 mm) diameter hole 22" inches (560 mm) deep into the rock. Install the HBA post in the hole. Cut off the embedded portion so the guardrail will be installed at the proper mounting height. Place in the bottom 2 inches (50 mm) of the hole for drainage granular material or small pieces of the drilled rock. Backfill and compact the hole after installing the HBA post. If compactable, the material removed from the hole may be used for the backfill.

If the finished grade is paved around terminal posts 1 and 2, a 3" deep recess around each post needs to be provided to allow for the top post to rotate when impacted. (See Figures 6 and 7). The recesses should not be filled with compacted asphalt or concrete.

INSTALLING HBA™ TOP POSTS

Once the bottom posts are installed, the upper post can be installed.

The post plates (ears) can be installed on either side of the bottom post plates (ears). At post location No. 1, install the upper post (PC-33876A) by aligning the holes of the post plates (ears) of the upper and lower posts. In the 7/16" (11 mm) holes, install a 3/8" (10 mm) diameter x 2" (50 mm) hex head bolt with a 3/8" (10 mm) washer, 3/8" (10 mm) lock washer under the 3/8" (10 mm) hex nut. **See Figure 2.**

The bolts should be installed so the head of the bolt is on the inside of the post plates (ears) and the washer and lock washer under the nut are on the outside of the post plates.

There is no torque requirement for these bolts. They should be tightened to a snug position.

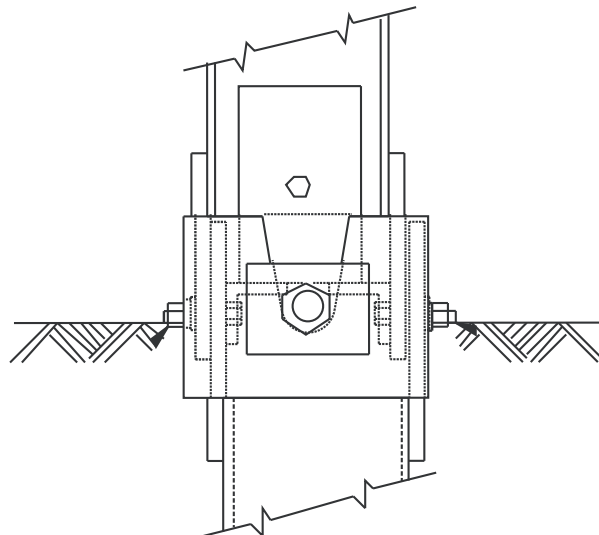

FIGURE 2

At Post Location No. 2, install the upper post (PC-33877A) by aligning the holes of the post plates (ears) on the upper and lower posts. In the 7/16" (11 mm) holes, install a 3/8" (10 mm) diameter x 2" (50 mm) hex head bolt with a 3/8" (10 mm) washer, 3/8" (10 mm) lock washer under the 3/8" (10 mm) hex nut. The bolts should be installed so the head of the bolt is on the inside of the post plates (ears) and the washer and lock washer under the nut are on the outside of the post plates (ears). **See Figure 3.**

There is no torque requirement for these bolts. They should be tightened to a snug position.

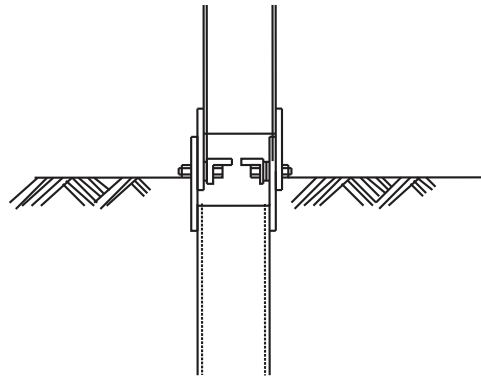

FIGURE 3

INSTALLING THE STRUT

Place the two angle struts (PC-33879G) between post 1 and 2. **See Figure 4.**

In the 13/16" (21 mm) hole of Post No. 1 post plates, install a 3/4" x 3" (19 mm x 75 mm) diameter hex head high strength bolt. The bolt is placed through the strut and through the two post plates. A 3/4" (19 mm) washer and a 3/4" (19 mm) lock washer are placed under the 3/4" (19 mm) hex nut.

In the 13/16" (21 mm) holes of Post No. 2 post plates, install a 3/4" x 3" (19 mm x 75 mm) diameter hex head high strength bolt. The bolt is placed through the strut and through the two post plates. A 3/4" (19 mm) washer and 3/4" (19 mm) lock washer are placed under the 3/4" (19 mm) hex nut. Two to three washers are stacked on the bolt between the strut and the inside post plate to allow the strut to pass over the 3/8" (10 mm) bolt head. See Figure 4.

There is no torque requirement for these bolts. They should be tightened to a snug position.

Stack 2-3 washers on 3/4" bolt
Between post plate & strut to allow
strut to pass over 3/8" bolt head.

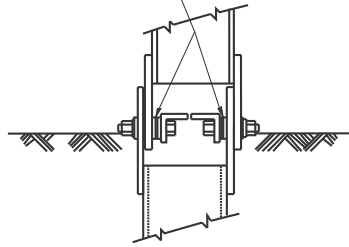

FIGURE 4

INSTALLING WOOD BLOCKOUTS AND RAIL PANEL

Guardrail panels (PC-30G and PC-39G and PC-69G) have two (2) sets of slots. These slots should be between posts 1 and 2, 2 and 3, 3 and 4, and 4 and 5. The guardrail panels should be installed so that the slot guard attachment holes are at the end of the slots away from the end of the terminal. **See Figure 5.**

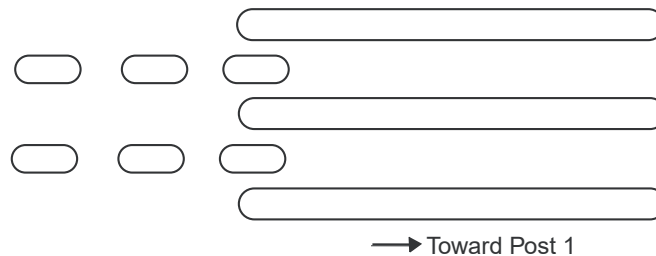

FIGURE 5

The 12'6" (3.81 m) guardrail panel (PC-39G) or 25'0" (7.62 m) guardrail panel (PC-69G) slots should be between posts 3 and 4 and posts 4 and 5.

The 12'6" (3.81 m) guardrail panel (PC-30G) anchor bracket holes will be between post 1 and post 2.

12'6" (3.81 m) PANEL OPTION:

At post location 7, splice and post bolt the 12'6" (3.81 m) rail panel (PC-9G) to the run of guardrail with hardware provided by the standard guardrail supplier.

The terminal rail should be lapped in the direction of traffic unless the agency's policy dictates otherwise.

At post location 5, splice the 12'6" (3.81 m) rail panel to the 12'6" (3.81 m) rail panel

(PC-39G) with eight (8) 5/8" x 1 1/4" (16 mm x 32 mm) splice bolts and hex nuts.

At post locations 4, 5, and 6, bolt the rail panel and wood blackout to the wood post using a 5/8" x 18" (16 mm x 460 mm) post bolt, a hex nut, and a round washer. The washer is installed between the wood post and the nut.

At post location 3, splice the 12'6" (3.81 m) rail panel (PC-39G) to the 12'6" (3.81 m) rail panel (PC-30G) with eight (8) 5/8" x 1 1/4"(16 mm x 32 mm) splice bolts and hex nuts. Bolt the rail panels and wood blackout to the wood post using a 5/8" x 18" (16 mm x 460 mm) post bolt, a hex nut, and a round washer. The washer is installed between the wood post and the nut.

At post locations 1 and 2, bolt rail panel to the wood posts using a 5/8" x 10" (16 mm x 255 mm) post bolt, a hex nut, and a round washer. The washer is installed between the wood post and the nut.

The wood offset block should be secured to prevent it from rotating. This can be done by toe nailing the block to the post or the post to the block using 16d hot-dipped galvanized nails. The nails should be installed approximately 3" (75mm) from the top of the post or block, one on each side.

25'0" (7.62 m) PANEL OPTION:

At post location 7, splice and post bolt the 25'0" (7.62 m) rail panel (PC-69G) to the run of guardrail with hardware provided by the standard guardrail supplier.

At post locations 4, 5, and 6, bolt the 25'0" (7.62 m) rail panel (PC-69G) and wood blockouts to the wood posts using a 5/8" x 18" (16 mm x 460 mm) post bolt, a hex nut, and a round washer. The washer is installed between the wood post and the nut.

At post location 3, splice the 25'0" (7.62 m) rail panel (PC-69G) to the 12'6" (3.81 m) rail panel (PC-30G) with eight 8 5/8" x 1 1/4"(16 mm x 32 mm) splice bolts and hex nuts. Bolt the rail panels and wood blackout to the wood post using a 5/8" x 18" (16 mm x 460 mm) post bolt, a hex nut, and a round washer. The washer is installed between the wood post and the nut.

At post location 2, bolt the backup rail panel (PC-3G) to the HBA Top Post using a 5/8" x 2" (16 mm x 50 mm) post bolt, a hex nut, and a round washer. The washer is installed between the post and the nut. Do not attach the rail to the post.

At post location 1, bolt the rail panel to the HBA Top Post using a 5/8" x 2" (16 mm x 50 mm) post bolt, a hex nut, and a round washer. The washer is installed between the post and the nut.

The wood offset block should be secured to prevent it from rotating. This can be done by toe nailing the block to the post or the post to the block using 16d hot-dipped galvanized nails. The nails should be installed approximately 3" (75mm) from the top of the post or block, one on each side.

INSTALLING SLOT GUARDS

Install the slot guards (PC-9960G) with the deflector angle closest to the elongated slots. Each slot guard is bolted to the backside of the guardrail panels with six (6) 5/8" x 1 1/4" (16 mm x 32 mm) splice bolts and hex nuts. It is suggested that the slot guards and the cable anchor bracket (PC-700A) be installed on the rail panels before going to the work site. This will expedite the installation.

INSTALLING THE CABLE ANCHOR ASSEMBLY

The cable anchor bracket (PC-700A) is bolted to the backside of the guardrail panel using eight (8) 5/8" x 1 1/2" (16 mm x 38 mm) hex bolts, eight (8) hex nuts, and eight (8) round washers. The round washers are installed between the bolt head and the rail panel on the traffic side.

Slide one end of the cable (PC-3000G) into the cable anchor bracket and the other end between the upper and lower HBA posts at location 1. Place a 1" (25 mm) washer on the end of the cable that extends through the cable anchor bracket.

On Post No. 1, bolt the 4" x 5 3/4" x 1/4" (100 mm x 146 mm x 6 mm) Cable Web Plate (PC-33881G) to the web of the post with a 3/8" x 1 1/2" (10 mm x 37 mm) hex head bolt, with a 3/8" (10 mm) washer under the 3/8" (10 mm) hex nut. The cable web plate should be pushing down on the top of the cable anchor. **See Figures 6 and 7.**

After the Cable Web Plate is installed, place the bearing plate (PC-33880G) with the open side of the V-notch pointing upward and the plate washer (PC-9961G) on the end of the cable. **See Figure 6.** The bearing plate should rest on the top of the flange of the HBA bottom post. **See Figure 7.**

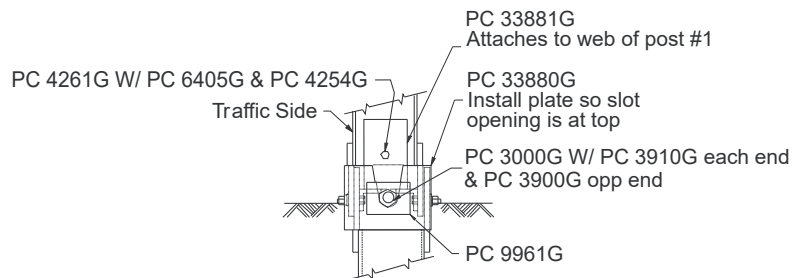

FIGURE 6

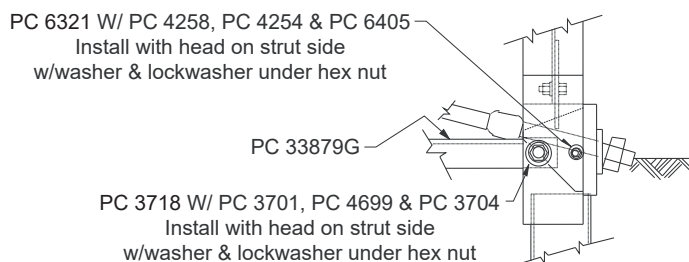

FIGURE 7

Secure each end of the cable with a 1" (25 mm) hex nut and tighten. Restrain the cable with vise grip pliers at the end being tightened to avoid twisting the cable. Make sure the nuts are tight and the cable is taut.

INSTALLING THE END SECTION

Install the end section (PC-907G) by connecting it to the end of the guardrail panel with four (4) 5/8" x 1 1/4" (16 mm x 32 mm) splice bolts and hex nuts.

SRT™ / HBA™ 6-POST SYSTEM INSTALLATION CHECKLIST

STATE: _____
DATE: _____
PROJECT: _____
LOCATION: _____

- The rail height is in accordance with the plans (generally 27 3/4" [706 mm] above the finished grade).
- The ears of the bottom HBA posts do not protrude more than 4" (100 mm) above the finished grade measured by the AASHTO 5'0" (1.5 m) cord method. Site grading may be necessary to meet this requirement.
- The 6" x 8" (150 mm x 200 mm) bearing plate at post 1 is correctly positioned and the anchor cable is taut and correctly installed (it should be rechecked after installation to be sure it hasn't relaxed).
- The rail panel is not attached to the posts at location 2. No rectangular washers are used on the face of the rail.
- Slot guards are in place and oriented correctly.
- Rail panels are oriented and lapped correctly.
- Blockouts have been toe nailed to the posts.
- The backfill material around the posts is properly compacted.
- The Controlled Released Terminal (CRT) post has two 3-1/2" (90 mm) breakaway holes (checked prior to installation). They should be located parallel to the roadway with the bottom of the top hole located approximately at the finished grade.
- If paved, the material around posts 1 and 2 is removed.
- The recesses are not filled with compacted asphalt or concrete.

MAINTENANCE/REPAIR INSTRUCTIONS FOR SRT™/HBA™ 6-POST SYSTEM GUARDRAIL END TERMINAL

MAINTENANCE

Maintenance consists of periodically checking the system to see that the cable is taut, the nuts have not been removed from the cable, and the blockouts have not rotated.

REPAIR

- (1) At the accident site, setup necessary traffic control and then remove any debris that has encroached onto the traveled way or shoulder. Install any necessary delineation necessary for the damaged system. Take inventory of the damaged system and determine what parts are reusable and what parts need to be replaced.
- (2) Obtain those parts that need to be replaced.
- (3) With the replacement parts, return to the repair site. To expedite the rail installation, it is suggested that any new rail panel(s) brought to the repair site should have the slot guards already bolted to it to minimize work zone repair time. The slot guards on the damaged rail panel(s) can be removed back at the maintenance yard and used on the next repair.
- (4) Disconnect and remove the damaged rail from the posts.
- (5) Remove any damaged Controlled Release Terminal (CRT) posts.
- (6) After the site has been cleared of damaged debris, the system can be reconstructed following the installation instructions.



For more complete information on Valtir products and services, visit us on the web at www.valtir.com. Materials and specifications are subject to change without notice. Please contact Valtir to confirm that you are referring to the most current instructions.

WWW.VALTIR.COM
1.888.356.2363