

Triton Barrier® TL-3

LONGITUDINAL WATER FILLED BARRIERS



BARRIERS

Triton Barrier® TL-3 Longitudinal Barrier

The Triton Barrier® TL-3 is a portable, water filled barrier for redirective applications. The Triton Barrier® TL-3 features a pedestal system that attaches with a steel strap and allows the use of existing Triton Barrier® TL-2 in NCHRP Report 350 Test Level 3 applications. It is tested to NCHRP Report 350 Test Level 3.

ASSEMBLY AND MAINTENANCE

- The minimum assembly length is 30 sections for Test Level 3.
- Lightweight sections can be unloaded and positioned by hand.
- Convenient forklift ports and fill level indicator.

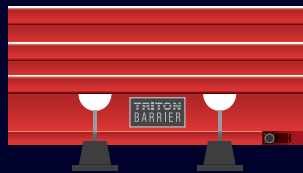

FEATURES

- Steel reinforced polyethylene barrier sections.
- Can be used as water filled longitudinal work zone barriers.
- First 20 sections of Triton Barrier® TL-3 can be used as end treatment.
- Transition hardware available for attachment to guardrail or concrete barrier.
- Cost effective compared to portable concrete barriers.
- Durable in adverse weather conditions.

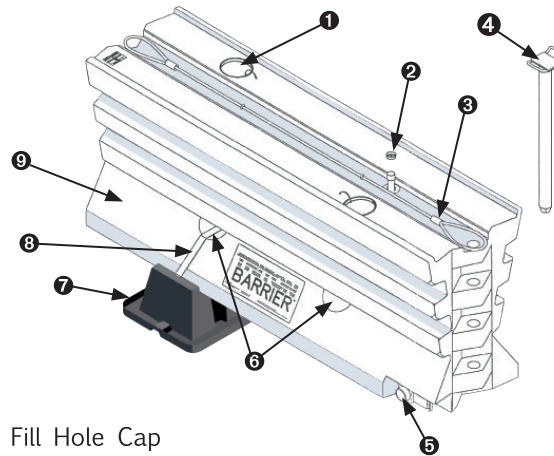

- 1 Fill Hole Cap
- 2 Fill Level Indicator
- 3 Factory Installed Tension Cable
- 4 Connecting Pin
- 5 Gate Valve Drain
- 6 Forklift Ports
- 7 TL-3 Pedestals
- 8 TL-3 Mounting Straps
- 9 6.5 ft (2 m) Steel Reinforced Barrier Section

SPECIFICATIONS

Triton Barrier® TL-2

- 6' 6" (2 m) Long
- 21" (533 mm) Wide
- 32" (813 mm) High
- 140 lbs. (65 kg) Empty Weight
- 1,350 lbs. (610 kg) Water Filled Weight
- 145 gallons (550 liters) Water Ballast

Triton Barrier® TL-3 (with Pedestal)

- 31" (787 mm) Long
- 16.5" (419 mm) Wide
- 9" (229 mm) High

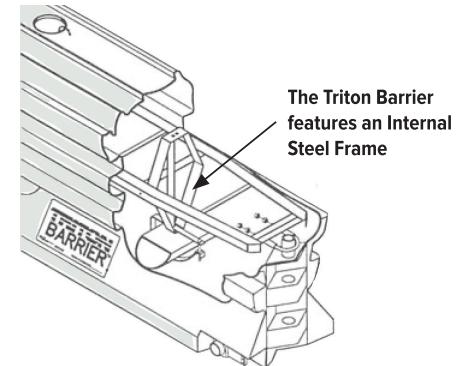

The Triton Barrier Pedestal

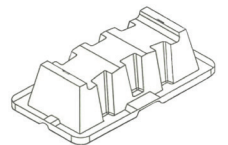

DISTRIBUTED BY