

Triton Barrier[®]CET

CONCRETE END TREATMENT



BARRIERS

Triton Barrier® CET Concrete End Treatment

The Triton Barrier® CET is a non-redirective, gating end treatment that consists of interlocking barrier sections made of polyethylene plastic and an internal steel framework. It is tested to NCHRP Report 350 Test Level 2 and Test Level 3. The system can be installed and removed from portable concrete median barrier (PCMB) and is potentially reusable after an impact within NCHRP Report 350 crash test standards.* Triton Barrier® CET is ideal for use in work zone applications.



FEATURES

- Steel reinforced polyethylene barrier sections.
- Can be used as a Test Level 2 or Test Level 3 water filled barrier with required minimum assembly length, or end treatment (first 10 sections of Triton Barrier® TL-2 or first 20 sections of Triton Barrier® TL-3).
- Convenient forklift ports and fill level indicator.
- Stackable for more efficient transportation and storage.
- Durable in adverse weather conditions.

SPECIFICATIONS

- 41' (12.5 m) Long
- 21" (500 mm) Wide
- 2' 8" (800 mm) High

ASSEMBLY AND MAINTENANCE

- Lightweight sections can be unloaded and positioned by hand.
- Connections are made with steel pins.
- Potentially reusable after an impact within NCHRP Report 350 crash test standards.*

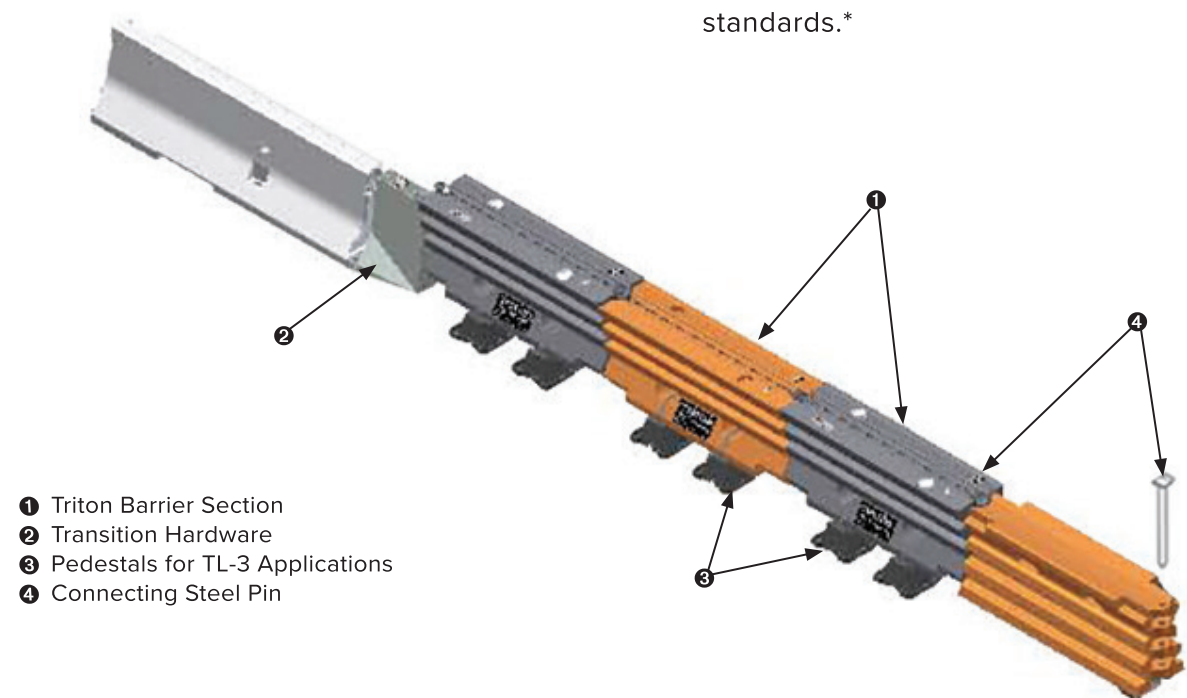

- ❶ Triton Barrier Section
- ❷ Transition Hardware
- ❸ Pedestals for TL-3 Applications
- ❹ Connecting Steel Pin

DISTRIBUTED BY