

SST<sup>®</sup>

TRAILER MOUNTED ATTENUATOR



# SST®

The SST® is a trailer mounted attenuator for use on stationary or moving shadow support vehicles. It is tested to NCHRP Report 350 Test Level 3. The system is comprised of two lightweight aluminum cartridges contained in a steel support frame, heavy duty Torflex® axle and wheels, with anti-rotational dampeners which lock upon impact. The SST® is designed to help absorb rear-end impacts at speeds up to 62 mph (100 km/h) when impacted within NCHRP Report 350 crash test standards.



## FEATURES

- Trailer system for more efficient deployment and truck fleet utilization.
- Anti-rotational dampeners are designed to help minimize rotation of unit when impacted within NCHRP Report 350 crash test standards.
- Heavy duty Torflex® axle and wheels.
- Arrow board mounting systems available.
- Designed to help minimize damage from low speed nuisance hits up to 6 mph (10 km/h).
- Potentially reusable steel frame after an impact within NCHRP Report 350 crash test standards.\*

## SPECIFICATIONS

- 18' 11" (5.77 m) Length
- 7' 9" (2.36 m) Width
- 3' 9" (1.14 m) Height
- 2,606 lbs. (1,182 kg)
- 9,920 lbs. (4,500 kg) Minimum Support Vehicle Weight

## ASSEMBLY AND MAINTENANCE

- Attaches to a standard minimum 20 ton pintle hook with additional mounting brackets for the anti-rotational dampeners.

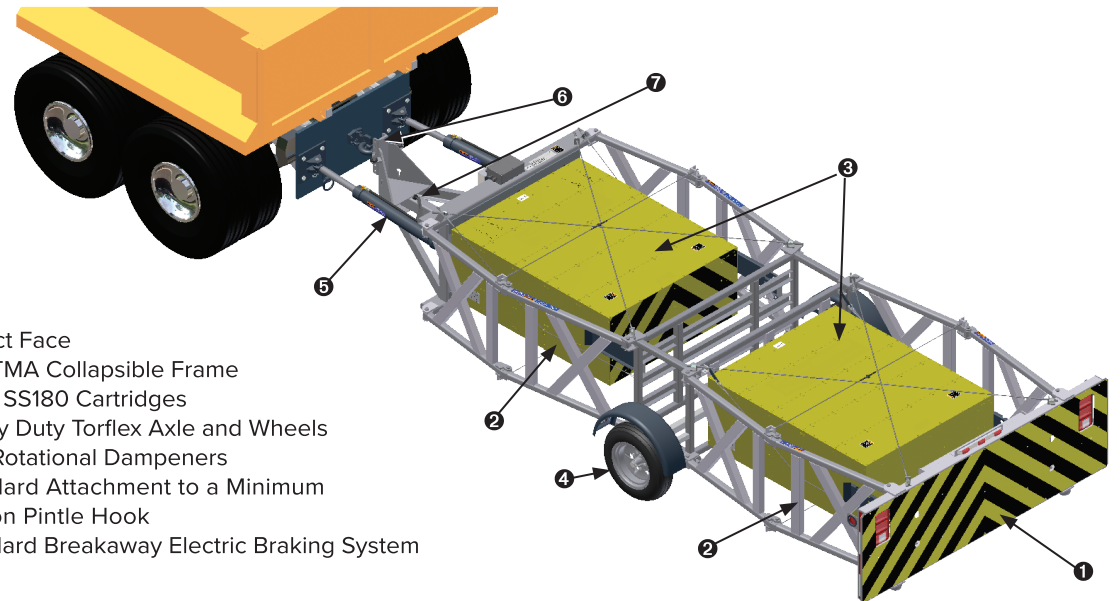

- 1 Impact Face
- 2 SST TMA Collapsible Frame
- 3 SST / SS180 Cartridges
- 4 Heavy Duty Torflex Axle and Wheels
- 5 Anti-Rotational Dampeners
- 6 Standard Attachment to a Minimum 20 Ton Pintle Hook
- 7 Standard Breakaway Electric Braking System

DISTRIBUTED BY