

NCHRP REPORT 350 DEPLOYMENT GUIDE – Yodock® 2001MB

The Yodock® 2001MB (“2001MB”) has been tested pursuant to National Cooperative Highway Research Program (“NCHRP”) Report 350 specifications.

The 2001MB is a plastic Longitudinal Channelizing Device (“LCD”) used for traffic and pedestrian channelization, road closure, and perimeter security for vertical construction.

The Federal Highway Administration (“FHWA”) has determined that the 2001MB is eligible for Federal-Aid reimbursement as an NCHRP Report 350 TL-3 LCD on the National Highway System.

When used with the Steel Rail Kit, the 2001MB is eligible for FHWA reimbursement as an NCHRP Report 350 TL-2 longitudinal barrier on the National Highway System.

Features

1. Interlocking Coupler
2. Light Box Recess
3. Fill Hole
4. Drain Plug
5. Drain Hole
6. Forklift Ports

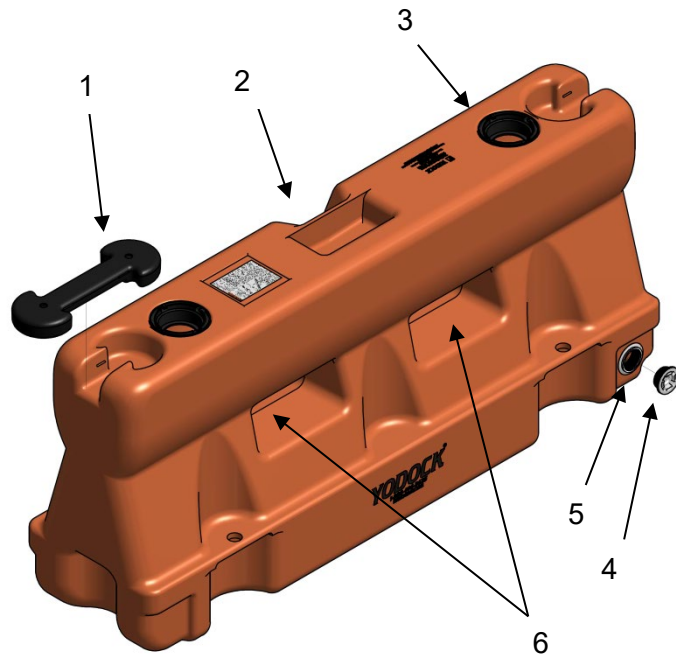

Specifications

- 6' length
- 18" width
- 32" height
- Empty: 85 lbs.
- Full: 900 lbs.
- Capacity: 100 gallons

Recommended Tools

- Drain Wrench



FAILURE TO FOLLOW INSTRUCTIONS MAY RESULT IN PROPERTY DAMAGE OR CAUSE SERIOUS INJURY TO PEDESTRIANS AND VEHICLE OCCUPANTS.

Longitudinal Channelizing Device (LCD) Deployment

1. Determine location of 2001MB deployment and follow instructions of highway authority or project manager (if available).
2. Deploy the barricades, empty or full, in line with each other and join each unit to the next using an Interlocking Coupler.
3. If a connection is required to make a corner, use the 2001MB Corner Connector and join it to the adjacent barricade run using an Interlocking Coupler.
 - a. Ensure that Connector Pins are securely in place.
 - b. Use the Interlocking Coupler to connect each side of the Corner Connector to the separate runs of 2001MB Barricades.

NOTE: It is not required to fill the Corner Connector with water.

4. Ensure that all Drain Plugs are properly secured.
5. If not already done, remove one (or both) Fill Caps.
6. Completely fill each 2001MB with water to the top of the Fill Hole.
7. Attach Fill Caps to prevent water loss and to keep debris out of the barricade.
 - 1) The LCD may be placed on cross slopes up to 5% (3°). – Figure A
 - 2) The LCD may be placed on longitudinal slopes up to 5% (3°). – Figure B
 - 3) The LCD has the ability to conform to a hill up to 5% (3°). – Figure C
 - 4) The LCD has the ability to conform to a ditch up to 5% (3°). – Figure D

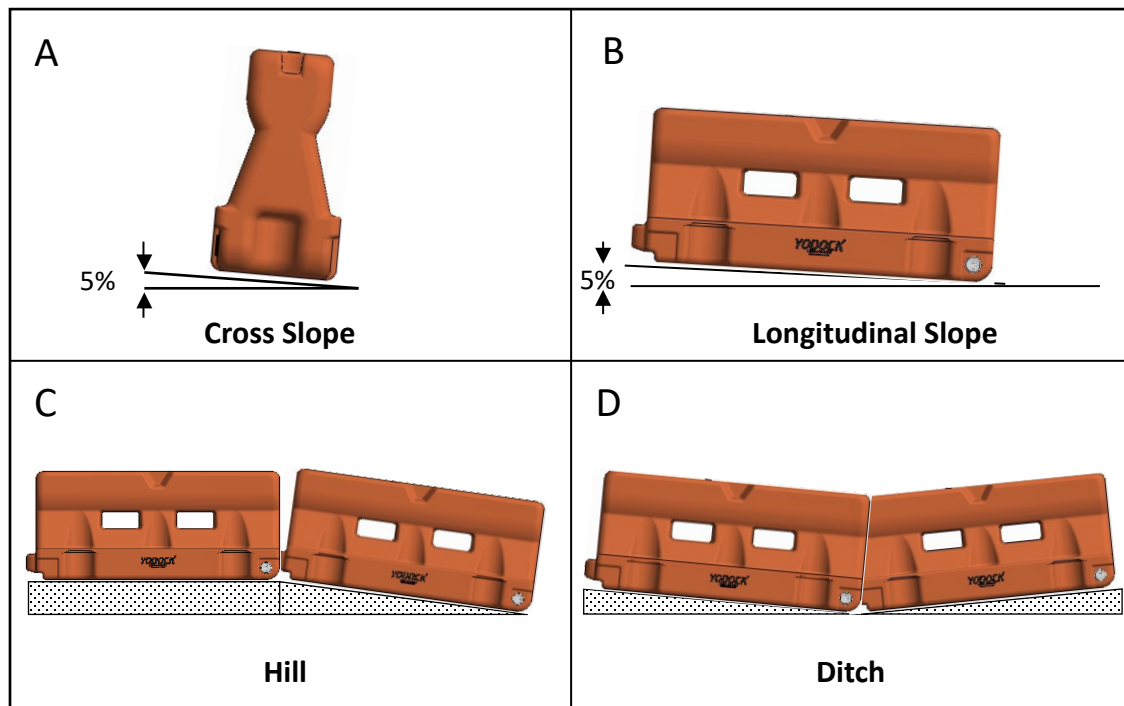

2001MB Removal

1. Loosen Fill Caps to facilitate water removal.
2. Remove Drain Plug at base of barricade and let water drain completely.
3. After barricade is empty, attach Drain Plug, Fill Cap, and remove Interlocking Coupler.
4. Empty barricades can now be removed for transport and storage.

Optional Corner Connector Removal

1. Remove the Interlocking Coupler from both sides of the Corner Connector.
2. Slide the Corner Connector away from each barricade run.
3. The Corner Connector can now be removed for transport and storage.

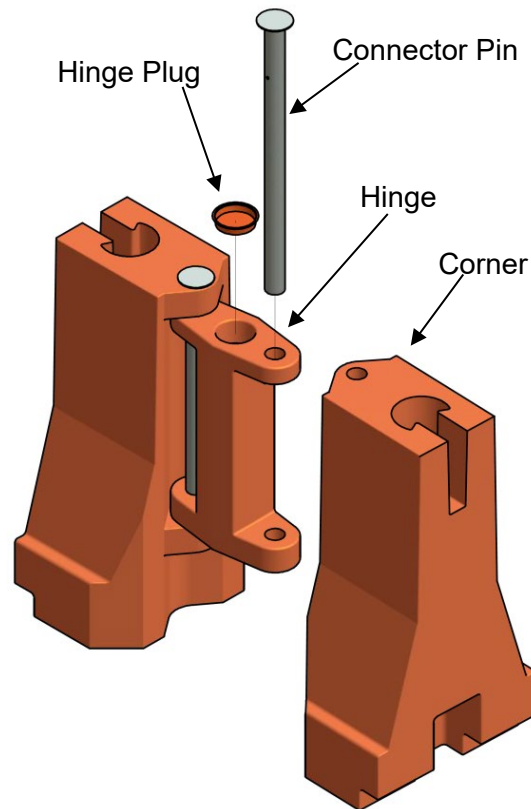

Corner Connector

Longitudinal Barrier (2001MB with Steel Rail Kit TL-2)



Important: To be used only with approved Steel Rail Kit (p. 5).

Deployment

1. Each Rail Kit contains two rails (one for each side of the unit), two Connector Channels, and Grade 8 hardware.
2. With the assistance of an additional person or persons (as needed), place one rail on each side of the unit in preparation to set them in place.
3. With the assistance of an additional person or persons (as needed), lift the rail and slide the protrusions into the 2001MB forklift ports. Repeat the process for the other side.
4. Adjust the rails on each side so that the corresponding bolt holes on each rail line up in the forklift ports.
5. Insert the provided Grade 8, 3/4" x 2" bolts through the holes of the protrusions. Use a washer on both the bolt head and nut side of each fastener. Tighten all fasteners with either a standard or pneumatic socket wrench.
6. Units with rails are joined together by a Connector Channel that is bolted to the corresponding holes at both ends of the rails with the provided Grade 8 fasteners.
7. Slide the Connector Channel over the end of the rail with **the open end facing out** and line up the corresponding bolt holes. Repeat for the opposite side of the unit. Place the provided 3/4" x 5 1/2" Grade 8 bolts through the Connector Channel and rail and attach remaining hardware. Tighten all fasteners with either a standard or pneumatic socket wrench. **Use a washer on both the bolt head and nut side of each fastener.**
8. Slide the adjoining unit with rail into the attached Connector Channel and align all bolt holes. Insert the provided 3/4" x 5 1/2" Grade 8 bolts and tighten the Connector Channel fasteners with either a standard or pneumatic wrench. **Use a washer on both the bolt head and nut side of each fastener.**
9. Refer to the local authority's traffic control plan for proper deployment.

NOTES:

1. Minimum deployment length for the 2001MB with Steel Rail Kit is 150'.
2. The beginning length of need ("BLON") for the 2001MB with Steel Rail Kit is 42'.
3. When deployed, the system with the Steel Rail Kit may present a blunt-end road feature to oncoming traffic. Consult local highway authority on an appropriate procedure to shield the blunt end or taper the end of the system out of the clear zone.

Note: For steps 4 – 7 refer to page 6.

4. The 2001MB may be placed on cross slopes up to 5% (3°). – Figure A
5. The 2001MB may be placed on longitudinal slopes up to 5% (3°). – Figure B
6. The 2001MB has the ability to conform to a hill up to 5% (3°). – Figure C
7. The 2001MB has the ability to conform to a ditch up to 5% (3°). – Figure D

STEEL RAIL KIT COMPONENTS

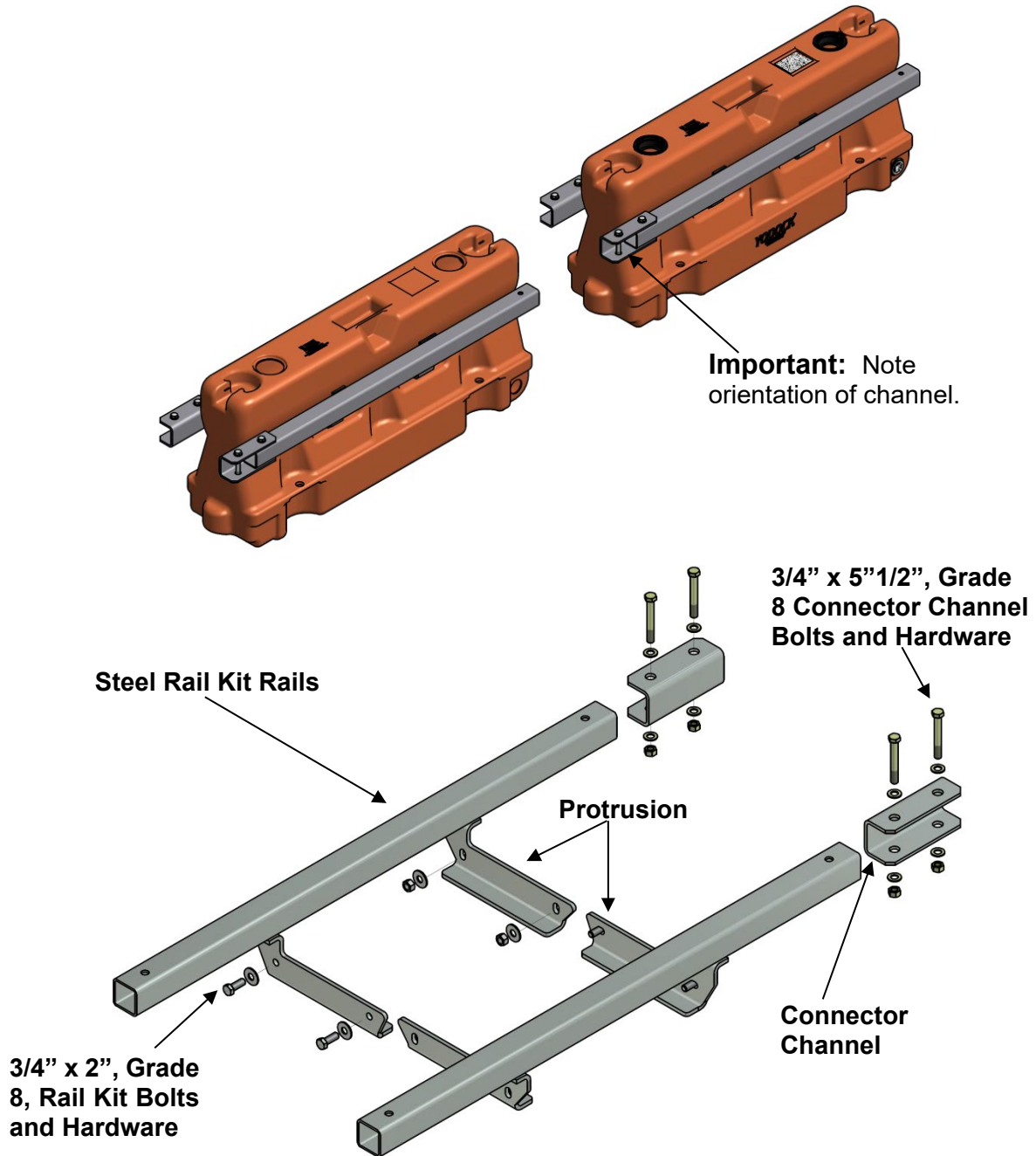

FAILURE TO FOLLOW INSTRUCTIONS MAY RESULT IN PROPERTY DAMAGE OR CAUSE SERIOUS INJURY TO PEDESTRIANS AND VEHICLE OCCUPANTS.

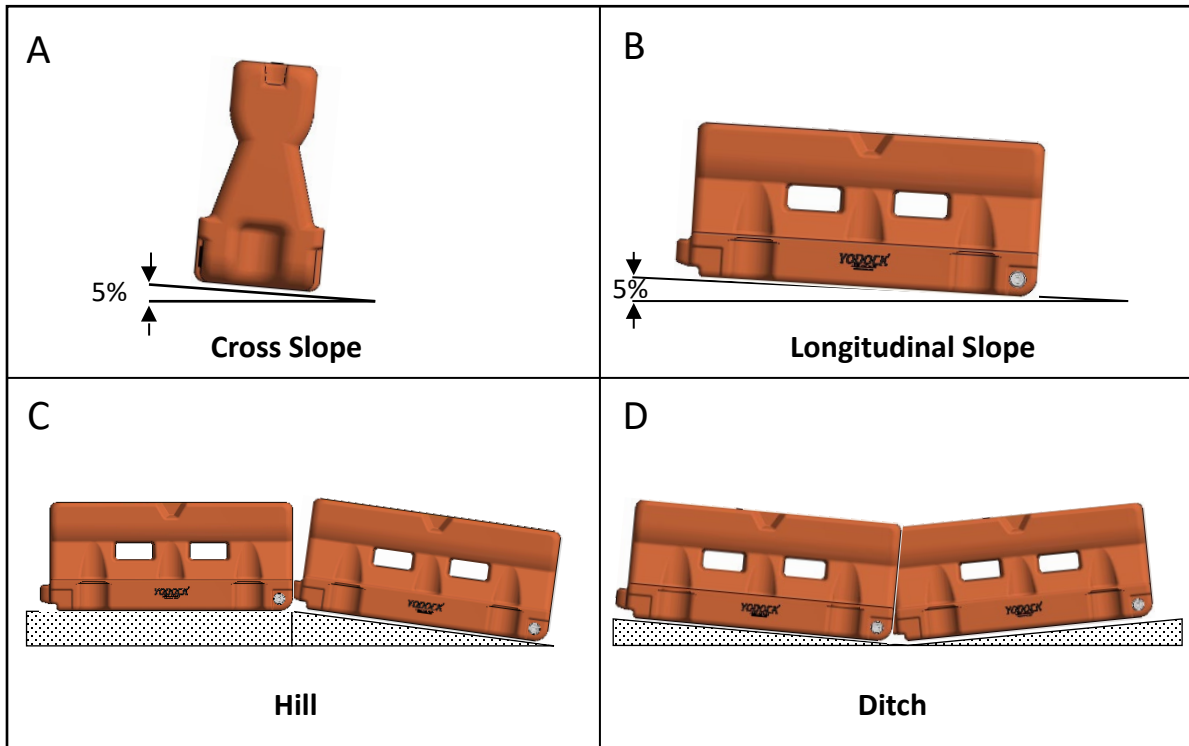
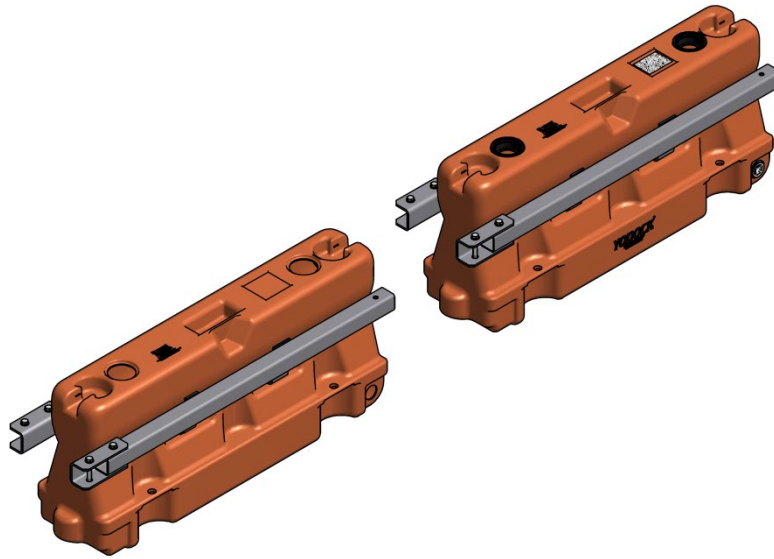

Removal

1. Remove the 3/4" x 5 1/2" bolts from Connector Channel – retain for possible reuse.
2. Remove the Connector Channel from the steel rails – retain for possible reuse.
3. Remove the 3/4" x 2" bolts that hold the two Steel Rail Kit halves together – retain for possible reuse.
4. With the assistance of an additional person or persons (as needed), lift the rail and slide the protrusions out of the fork lift ports of the unit. Repeat the process for the other side.

Perimeter Security with Fence Panel Deployment



Warning: The 2001MB with Fence Panels should only be deployed on level ground.

1. Position each 2001MB in line with the next using an Interlocking Coupler.
2. If a connection is required to make a corner, use the 2001MB Corner Connector and join it to the adjacent 2001MB Barricade run using an Interlocking Coupler (p. 3).
3. Ensure that all Drain Plugs are properly secured.
4. If not already done, remove one (or both) Fill Caps.
5. **Completely fill each 2001MB Barricade with water to the top of the fill port. Failure to completely fill the barricades could result in unwanted tipping of the system.**
6. Slide Rubber Grommets onto each Fence Panel Post. With two people, lift the Fence Panel on top of the barricade and place the Fence Panel Posts into the Fill Holes. The posts should seat firmly within the pockets of the base inside the barricade with the Rubber Grommets snug in the Fill Holes. The chain link mesh should be faced out from the barricade.
7. Interconnect the Fence Panels using two (2) Fence Panel Clamps, each one approximately 12" from the top and bottom of the Fence Panel.
8. **Valtir does not recommend the use of a windscreen, however; if a wind or debris screen is required, attach the screening to the top and bottom of the Fence Panel Rails using approved plastic zip ties to secure all screen grommets.**



Danger: Do not attach privacy, debris or wind screens (or remove if already in place) if wind gusts are expected to exceed 45 mph. Failure to do so may result in the system being blown over and causing property damage, personal injury or death.

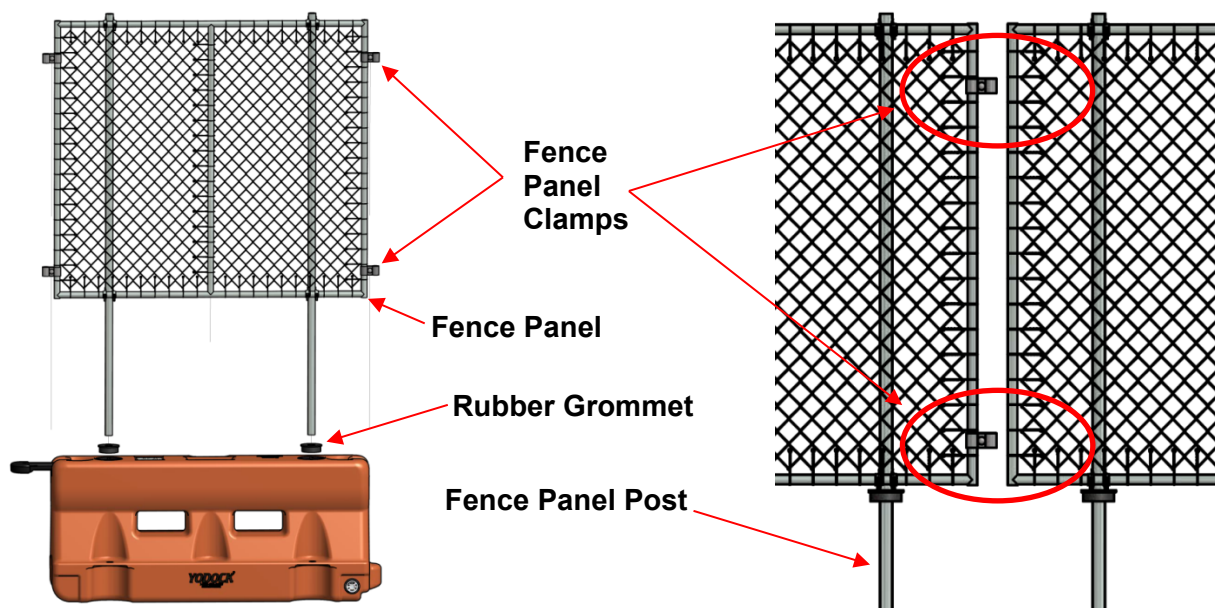

Perimeter Security with Fence Panel Removal

1. Remove wind or debris screens (if attached).
2. Remove Fence Panel Clamps.
3. With the assistance of an additional person or persons (as needed), lift the Fence Panel out of the barricade and place on the ground. Remove and retain each Rubber Grommet.
4. Remove Drain Plug at base of each barricade and let water drain completely.
5. When barricade is empty, attach Drain Plug, Fill Caps and remove Interlocking Coupler.
6. Empty barricades and Fence Panels can now be removed for transport and storage.

Cold-Weather Environments and Anti-Freeze Recommendations

1. Choose the level of freeze point protection anticipated.
2. Choose your anti-freeze agent from the charts below.
3. Use the appropriate anti-freeze agent for your location when filling the 2001MB.

Chart 1 Anti-Freeze Chemicals - Mix per Section						
Yodock Model		2001MB				
Required Freeze Point Protection		20° F	10° F	0° F	-10° F	-20° F
Dry Material - in lbs.	Calcium Chloride (CaCl ₂)	81	122	146	178	195
	Calcium Magnesium Acetate (CMA)	130	178	219	251	268
	Magnesium Chloride (MgCl ₂)	73	105	130	146	162
	Potassium Acetate (Kac)	73	162	203	243	276
	Sodium Chloride (NaCl ₂)	81	97	170	N/A	N/A
Liquid Material - in Gallons	Ethylene or Propylene Glycol	17	25	32	38	43

Chart 2 Anti-Freeze Chemicals - Bulk Mix						
Freeze Point Protection		20° F	10° F	0° F	-10° F	-20° F
Dry Material - Lbs./Gallon	Calcium Chloride (CaCl ₂)	0.8	1.2	1.5	1.8	2.0
	Calcium Magnesium Acetate (CMA)	1.3	1.8	2.2	2.6	2.7
	Magnesium Chloride (MgCl ₂)	0.7	1.1	1.3	1.5	1.7
	Potassium Acetate (Kac)	0.7	1.7	2.1	2.5	2.8
	Sodium Chloride (NaCl ₂)	0.8	1.0	1.7	N/A	N/A
Liquid Material - Volume Mix Ratio	Ethylene or Propylene Glycol	17%	25%	33%	39%	45%

Note: The two charts are for reference only and do not guarantee freeze prevention.

1. For those mixtures that may be slick, if a spill occurs, the solution should be washed away with large amounts of water and the area sanded to prevent skidding.
2. Before an antifreeze solution is chosen, the user should check local ordinances regarding environmental issues.

QUESTIONS: For questions, requests, or additional copies, please contact Valtir at 888.356.2363 or visit Valtir.com.