

Vulcan™ Transfer Attachment

STEEL BARRIER

PRODUCT DESCRIPTION ASSEMBLY MANUAL

Vulcan™ Transfer Attachment

Table of Contents

System Overview	2
General Product Specification	3
Choosing an Appropriate Host Vehicle	5
Assembly Instructions	6
Installation Instructions	7
Adjustment Instructions	8
Operating Instructions	10
Tips for Optimal Use	11
Storage Instructions	12
Maintenance	13
Limitations & Warnings	15
System Drawings	16

Important Introductory Notes

This manual contains important information about the Vulcan Transfer Attachment (VTA.) Proper installation and operation of the VTA is essential to ensure maximum performance. Please review this manual thoroughly prior to installing and/or operating the Valtir, LLC., VTA.

If you need additional information, or have any questions about the VTA, please call Valtir Customer Service Department at 1-888-323-6374.

RETURN GOODS POLICY

Before returning any goods for credit please contact Valtir, LLC. Customer Service Department at 1-888-323-6374 or your local distributor for proper instructions.

System Overview

The Vulcan Transfer Attachment (VTA) is a tool that is attached to commonly available construction equipment such as skid-

steers and articulated front end loaders. The VTA allows the Vulcan steel barrier to be quickly and easily moved to open or close lanes in a road construction zones.

The VTA is designed to allow easy attachment to the front of construction equipment via existing OEM and third-party quick change couplers. The VTA can be attached so that it is cantilevered to either the right or left side of the host vehicle, making it possible to move barrier from either side of the host vehicle (see Figure 1). This design allows the host vehicle to remain completely on one side (typically the non-traffic side) of the Vulcan barrier being moved. There may be construction sites, such as trenching operations, where placement of the barrier will not leave room for the host vehicle behind the barrier. In these settings, the ability to mount the VTA on the right or left side of the host vehicle ensures that the host vehicle remains completely on the non drop-off side of the barrier.

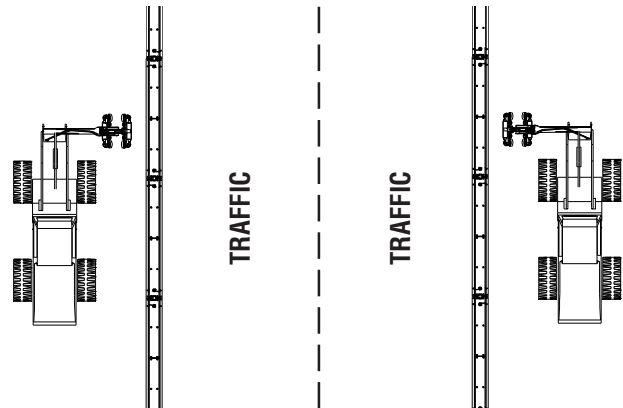

Figure 1

The VTA's carriage is specially designed to interface with the profile of Vulcan barrier. This is accomplished by strategically locating guide and lifting wheels to interface with specific portions of the Vulcan's three beam barrier. Heavy duty lifting wheels support the Vulcan's three beam at the structurally reinforced center hump, while outboard guide wheels ensure that the top and bottom humps of the three beam remain aligned within the VTA's carriage. This design allows the VTA to lift and move the Vulcan barrier without damage to the barrier.

When not in use, the VTA can be removed from the host vehicle and stored free standing.

Vulcan™ Transfer Attachment General Product Specifications

I. GENERAL

All Vulcan Transfer Attachment Arms shall be designed and manufactured by Valtir, LLC.

II. DESCRIPTION OF SYSTEM

A. General

The Vulcan Transfer Attachment (VTA) is a tool that is attached to commonly available construction equipment such as skid-steers and articulated front end loaders. The VTA allows the Vulcan™ steel barrier to be quickly and easily moved to open or close lanes in road construction zones.

The VTA is designed to allow easy attachment to the front of construction equipment via existing OEM and third-party quick change couplers. The VTA can be attached so that it is cantilevered to either the right or left side of the host vehicle making it possible to move barrier from either side of the host vehicle. This design allows the host vehicle to remain completely on one side (typically the non-traffic side) of the Vulcan barrier being moved. There are also construction settings, such as trenching operations, where placement of the barrier will not leave room for the host vehicle behind the barrier. In these settings, the VTA ensures that the host vehicle remains completely on the not drop-off side of the barrier.

The VTA's carriage is specially designed to interface with the profile of Vulcan barrier. This is accomplished by strategically locating guide and lifting wheels to interface with specific portions of the Vulcan's three beam barrier. Heavy duty lifting wheels support the Vulcan's three beam at the structurally reinforced center hump, while outboard guide wheels ensure that the top and bottom humps of the three beam remain aligned within the VTA's carriage. This design allows the VTA to lift and move the Vulcan barrier without damage to the barrier.

B. Component Description

Support Arm

The support arm shall be fabricated from steel plate and shall be powder coated after fabrication. The host vehicle end of the support arm shall include a vehicle interface assembly specially designed to interface with the host vehicle used to deploy the VTA. The interface will typically consist of an OEM or third-party quick attachment. The carriage end of the support arm shall include attachment points for the alignment hinge.

Alignment Hinge

The support arm shall be attached to the head assembly with an alignment hinge. The alignment hinge shall consist of a heavy duty pin that attaches the support arm to the head assembly via round tubing. The two sides of the hinge shall be biased towards a centered position by two compression springs, one on each side of the hinge. Although the springs hold the head assembly in a neutral position when it is unloaded, the hinge is able to move up to 12 degrees to each side of the neutral position when the carriage is loaded. This allows the carriage to self-adjust to barrier sections that have a slight angle between them without becoming snagged.

Head Assembly

The head assembly shall be comprised of two carriage assemblies joined together by the clamshell mechanism. The clamshell mechanism allows the VTA to be easily placed on a run of Vulcan barrier to allow them to be moved. The clamshell mechanism shall consist of an inner and outer half, actuated by a hydraulic cylinder. The hydraulic cylinder shall include attachment hoses that enable it to be actuated via a host vehicle's auxiliary hydraulics.

Vulcan™ Transfer Attachment

Carriage Assemblies

Each of the carriage assemblies will include specifically designed lift and guide wheels. The lift wheels shall be high capacity rubber treaded wheels that are 10 inches in diameter with a 3 inch tread width. They shall include a recessed bore to allow their attachments bolts to be recessed from the face of the wheel. The alignment wheels shall be high capacity rubber treaded wheels that are 8 inches in diameter with a 2 inch tread width.

C. Material Specifications

1. Metal work shall be fabricated from either M1020 Merchant Quality or ASTM A-36 steel. After fabrication, metal work shall be powder coated in construction yellow. All welding shall be done by or under the direction of a certified welder.
2. The system shall be assembled with galvanized and stainless steel fasteners. All bolts, nuts and washers shall be Commercial Quality “American National Standard” unless otherwise specified.

III. INSTALLATION, OPERATION, AND MAINTENANCE

Installation, operation and maintenance of the Vulcan Transfer Attachment shall be accomplished in accordance with the recommendations of Valtir, LLC.

Choosing an Appropriate Host Vehicle

The appropriate type of host vehicle to use with your VTA will depend upon whether you ordered the Skid-Steer VTA or the Front End Loader VTA. Each Front End Loader VTA is designed for a specific type of quick coupler. For example: the CAT Front End Loader VTA is specifically designed to attach to CAT front end loaders equipped with the CAT Integrated Tool Carrier. A Front End Loader VTA is also available for the JRB & Volvo Wheel Loader Coupler which is a third-party attachment that is common on many makes of front end loaders.

If you ordered the Skid Steer VTA, your attachment should fit on most makes of Skid Steers. However, for the best performance and to minimize the risk of the host vehicle tipping, the following should be used as minimum specifications for the skid steer vehicle.

Vehicle Weight

3,700 kg (8,160 lbs)

Vehicle Rated Operating Capacity (SAE)

1,360 kg (3,000 lbs)

Vehicle Tipping Load

3,000 kg (6,610 lbs)

Please note that your host vehicle will also need to be equipped with in-cab controlled auxiliary hydraulics. The auxiliary hydraulics allow opening and closing of the clamshell carriage on the VTA. Most skid steer tractors are equipped with auxiliary hydraulics and this feature is also common on tool changer equipped front end loaders. The VTA comes equipped with standard hydraulic hoses, without couplers. The user is responsible for adding couplers that are appropriate for the auxiliary hydraulics ports on the host vehicle that is chosen.

Vulcan™ Transfer Attachment Assembly Instructions

The Vulcan Transfer Attachment (VTA) will arrive in a crate and some assembly will be required. After unpacking the VTA, locate the wheel subassemblies, which are packaged within the crate. Assemble the VTA by performing the following steps:

1. Mount the VTA on the appropriate host vehicle or block up the VTA to provide access to the lower area of the carriers.
2. Assemble the six 10" x 3" wheels to the carriers using the 1"-14 x 9" bolts, bearings, shields, flat washer and two 1"-14 jam nuts on each bolt. See Figure 2.

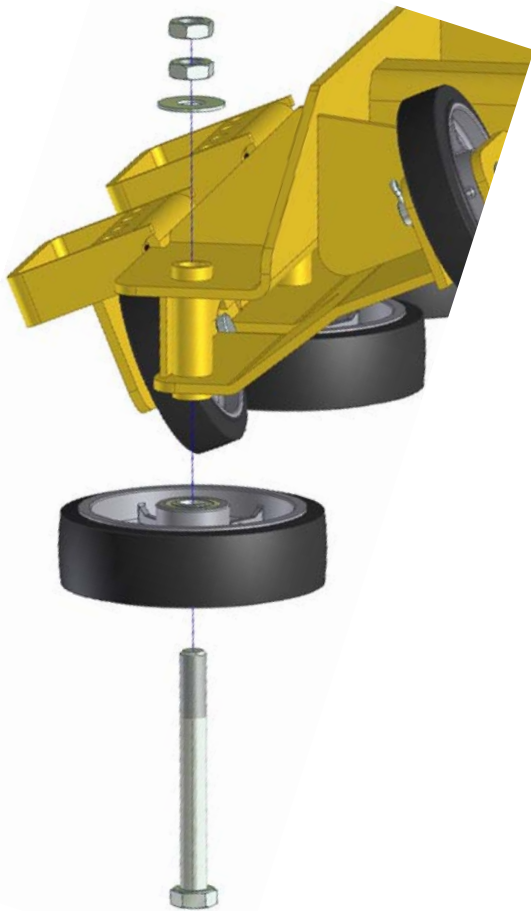

Figure 2
Assembly of the 10" x 3" Wheels

3. Tighten the first jam nut while spinning the wheel. When the wheels begin to bind back off the jam nut one half turn. Tighten the second jam nut onto the first jam nut locking the wheel into position.
4. Locate the grease fitting and apply grease until grease is pushed out at the bearing shields.
5. Install the four 8"x2" wheels by pinning the wheels into position with the provided 1" x 4" clevis pins and cotter pins. These wheels have sealed bearings and require no grease. See Figure 3.

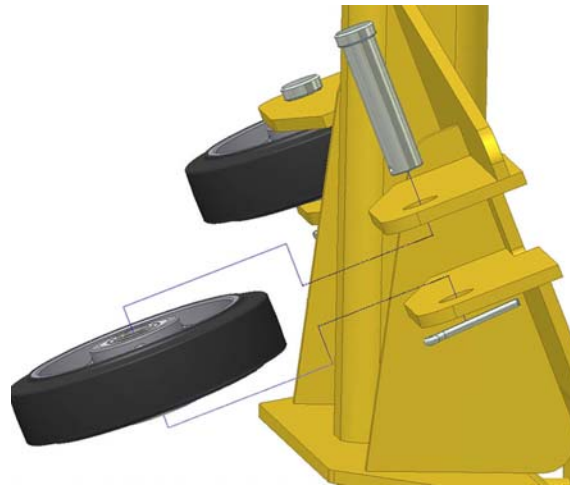

Figure 3
Assembly of the 8" x 2" Wheels

Vulcan™ Transfer Attachment Installation Instructions



Figure 4

The Vulcan Transfer Attachment (VTA) is designed to attach to the host vehicle so that it extends to either the right or left side. Determining which side to attach the VTA is dependant upon the layout of the Vulcan Barrier and the work zone that is being created. If possible, work on the side of the Vulcan Barrier that will minimize operator/vehicle exposure to traffic (see Figure 5). After determining which side of the attachment to use, install the VTA using the following steps:

1. Line up the host vehicle tool carrier perpendicular to the attachment, positioning the tool carrier lugs under the attachment hooks, then lift the VTA as the tool carrier is rotated in to position.
2. Engage the tool carrier locking pins and confirm their engagement.
3. Attach the hydraulic lines to the tractor hydraulic quick couplers. Be sure to check that the hoses/fittings are placed clear of any moving parts. Ninety degree fittings may need to be added for clearance. Do not use the host vehicle's high flow hydraulic ports.

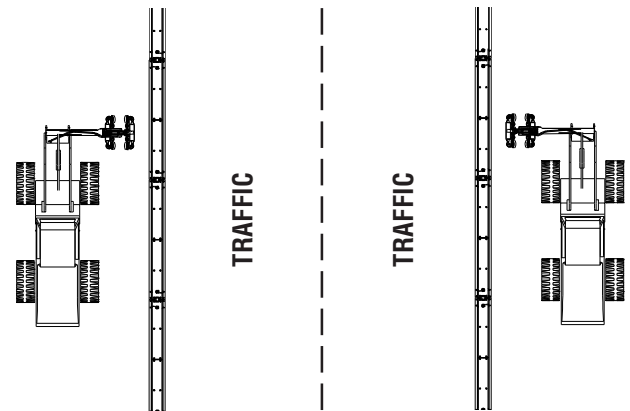

Figure 5

CAUTION! The VTA has exposed mechanisms. To prevent injury keep all personnel well clear of the area where the VTA is being used.

CAUTION! Vulcan Barrier being moved by the VTA articulates and is lifted off the ground. This creates pinch points between Barriers and underneath Barriers. Keep all personnel well clear of Vulcan Barrier being moved.

CAUTION! To ensure that the VTA does not pinch the hands, arms, or other parts of the body, lower the carriage to the "closed" position. Turn off the host vehicle and relieve hydraulic system pressure before attempting adjustment of the VTA.

Vulcan™ Transfer Attachment Adjustment Instructions

Because of the many different sizes and types of vehicles, the VTA has built-in adjustments to adapt to the specific make and model of vehicle being used. This is necessary because each vehicle's suspension system will cause the VTA to lean to the side by a different amount. To adjust the VTA to the host vehicle you are using, take the following steps.

1. Install the VTA onto the host vehicle and attach the quick couplers (for details on how to do this, see the "Installation Instructions" section of this manual.) Verify that the vehicle controls cause the correct movement of the driven carrier assembly from the operator's perspective.
2. Open the VTA carrier assembly and position it over a length of Vulcan barrier. Position the VTA on a barrier that is at least 3 to 4 barriers from the end of the string so that the typical weight of the barrier will be applied to the VTA. Close the carrier assembly around the barrier. The VTA carriage should be positioned on the barrier so that the 10" diameter lift wheels are positioned below the middle hump of the thrie beam. This is best done by lowering the 10" diameter lift wheels several inches below the middle hump of the barrier, then closing the VTA

carrier assembly and finally lifting the VTA so that the 10" wheels contact the bottom of the middle hump. See Figures 6 & 7.

3. With the carrier assembly fully closed around the barrier, inspect how tightly the carrier clamps the barrier. The large 10" support wheels should support the middle hump of the barrier, without tightly clamping around the lowest hump of the barrier's thrie beam. The lower 8" guide wheels should touch the barrier, with only a small amount of compression. See Figure 7.

CAUTION! The VTA has exposed mechanisms. To prevent injury keep all personnel well clear of the area where the VTA is being used.

CAUTION! Vulcan Barrier being moved by the VTA articulates and is lifted off the ground. This creates pinch points between the Barriers and underneath the Barriers. Keep all personnel well clear of Vulcan Barrier being moved.

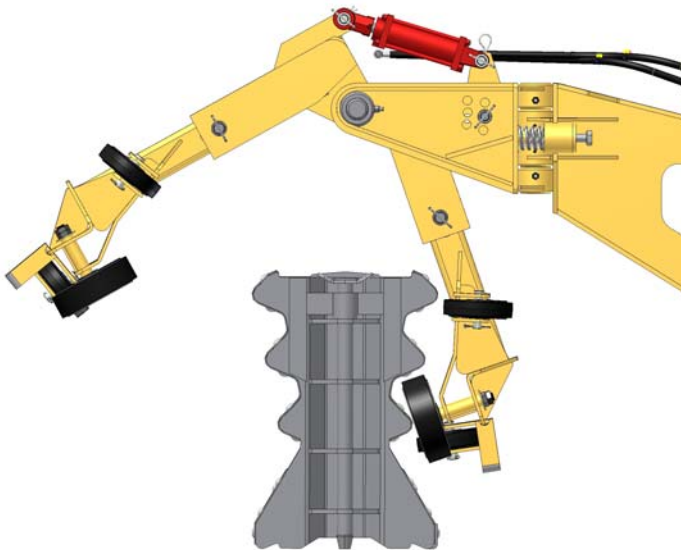

*Figure 6
Positioning the Carrier on the Vulcan
Barrier*

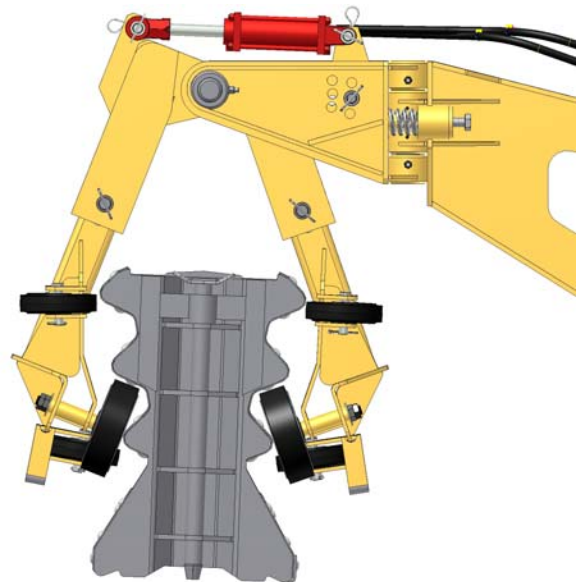

*Figure 7
Carriage Assembly Clamped on the Vulcan
Barrier*

- The clamping of the VTA is adjustable, should this be necessary. To do this, remove the hitch pin from the rod end side of the carrier assembly's hydraulic cylinder. The rod end's clevis is threaded onto the cylinder rod. To adjust the clevis, loosen the clevis' clamping bolt and thread the clevis in or out. Threading in will open/widen the carrier assembly and threading out will close/narrow the carrier assembly. See Figure 8.

CAUTION! To ensure that the VTA does not pinch the hands, arms, or other parts of the body, lower the carriage to the "closed" position. Turn off the host tractor, and relieve hydraulic system pressure, before attempting adjustment of the VTA.

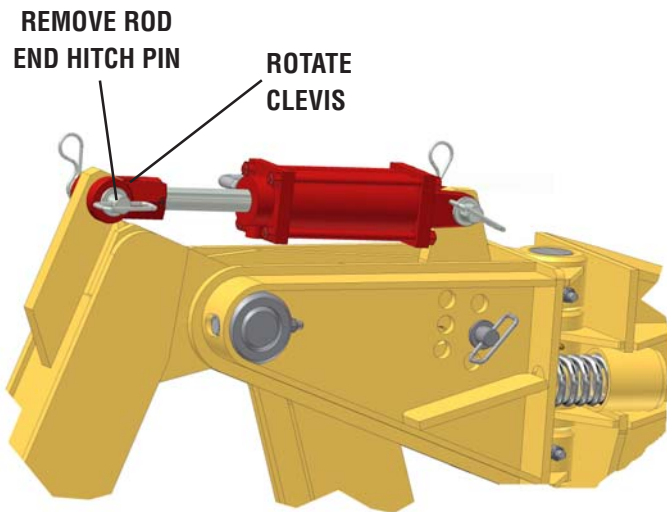

Figure 8

Adjusting the Hydraulic Cylinder's Rod End Clevis

- Once proper adjustment of the rod end's clevis has been attained, tighten the clevis' clamping bolt and reinstall the rod end hitch pin. Test the clamping of the carrier assembly to make sure that it is adequately adjusted.
- Lift the barrier 4" to 6" off of the ground.

- The Head Assembly is adjustable to counteract the lean of the tractor and to maintain a level interface to the barrier. Inspect the barrier's lean and adjust the head by choosing an appropriate hole for the adjustment hitch pin. The carriage assembly is correctly adjusted when the bottom of the barrier is roughly parallel with the road surface. See Figure 9.

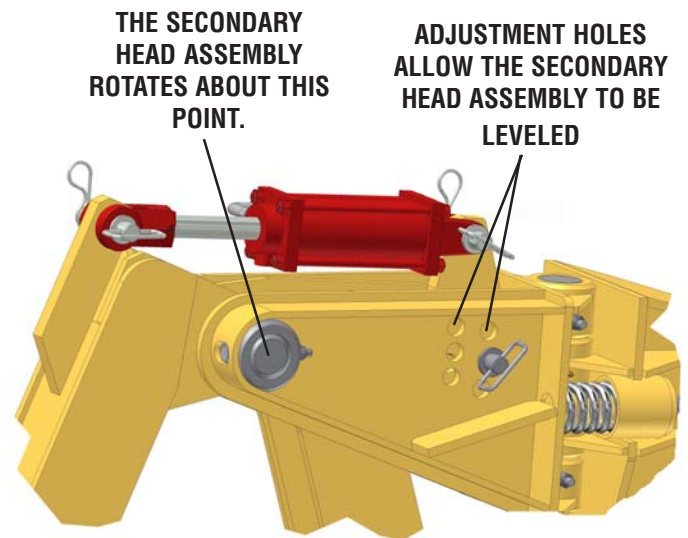

Figure 9

Carriage Tilt Adjustment

- Actuate the Vulcan Transfer Attachment (VTA) several times to verify the correct movement of the outer carrier arm from the operator's perspective.
- The small tractor VTA is equipped with a rear view mirror. Adjust the mirror, as needed.

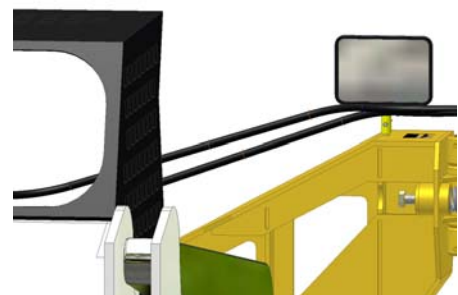

Figure 10

Vulcan™ Transfer Attachment

Operating Instructions

1. Using a person acting as a spotter, extend the outer carrier and drive parallel to the Vulcan Barrier and position the inner carrier against the barrier. See Figure 6. As the spotter indicates adjustment, lower the outer carrier on to the other side of the barrier See Figure 7. The spotter will verify that the carrier wheels are properly engaged before moving the barrier. The VTA carriage should be positioned on the barrier so that the 10" diameter lift wheels are positioned below the middle hump of the thrie beam. This is best done by lowering the 10" diameter lift wheels several inches below the middle hump of the barrier, then closing the VTA carrier assembly and finally lifting the VTA so that the 10" wheels contact the bottom of the middle hump.
2. Lift the Vulcan Barrier with the Vulcan Transfer Attachment approximately 4" – 6" off the ground. With the work zone layout in mind begin moving the barrier into place at a slow, steady pace and continue down the barrier string, making adjustments as needed. If the Vulcan Barrier begins to lean over adjust the side pressure until it is vertical. If needed, repeat the operation to straighten or increase the area of the work zone.

CAUTION! Do not lift the Vulcan Barrier higher than 4"-6" off the ground or an uncontrolled overturning moment may cause the host vehicle to roll.

CAUTION! Use extra caution whenever the VTA is used on soft, uneven, or wet surfaces, so that control of the host vehicle and VTA is maintained at all times.

Vulcan™ Transfer Attachment Tips for Optimal Use of the VTA

These tips and suggestions will help operators get the best performance from their Vulcan Transfer Attachment (VTA) and Vulcan barrier.

1. Make sure the host vehicle's wheels are properly inflated, per the manufacturer's recommendations. Tires with low air pressure can cause the tractor to lean excessively towards the barrier, which can cause excessive wear to the barrier, as well as the VTA. Moving the barrier will also be more difficult.
2. Barrier that is transported or moved often may develop loose hardware. Check the barrier hardware periodically for tightness and tighten any loose hardware that is found. Loose hardware may cause the barrier to perform poorly during a vehicle impact. Loose hardware can also cause damage to the VTA when it is moving the barrier.
3. Although the VTA can be used to move barrier by either pushing or pulling the barrier, pushing the barrier may result in better performance. Pulling the barrier may result in the barrier contacting the rear wheels of the host vehicle, limiting the move distance. For optimal performance, plan work zones so that the barrier can be pushed, rather than pulled.
4. Should the barrier become snagged in the VTA during a barrier move, decelerating and turning the host vehicle slightly away from the barrier may alleviate the snag and allow the barrier move to continue. If the snag does not release, stop the host tractor and inspect the barrier and VTA to determine what has caused the snag.
5. Periodically visually inspect the condition of the barrier. Barrier that is dented, bent or otherwise deformed should be replaced, as this may snag the VTA.
6. Check that the Vulcan barriers that are moved have their feet properly installed. These feet minimize damage to the roadway. Also check that these feet are properly aligned as a misaligned foot may dig into the road surface.
7. When moving the barrier, drive parallel to the direction of the barrier. Attempting to drive at an angle to the barrier may cause the VTA to snag. When beginning a move, it is best to move the end of the barrier laterally, before engaging the VTA.
8. When moving the barrier, only lift the barrier 4-6" off of the road surface. Keeping the barrier close to the ground maximizes its stability, while minimizing the stress to the VTA and the barrier.
9. When engaging the VTA's carrier and when using the VTA to move barrier, make sure that the carriage is level and horizontal. If the carriage is tilted from the horizontal, less than the full compliment of six 10" lifting wheels may lift the barrier. This will place undue stress on the VTA and also increase the likelihood of the VTA snagging the barrier.

Vulcan™ Transfer Attachment Storage Instructions

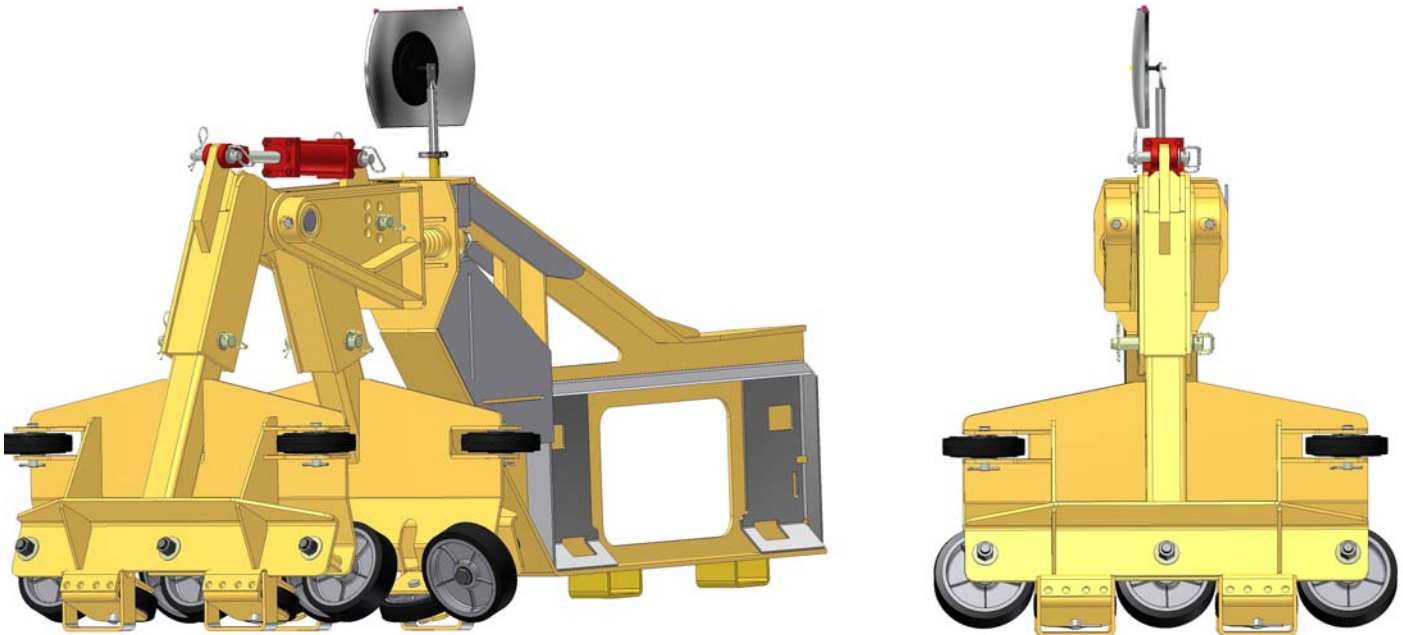

Figure 11

The Vulcan Transfer Attachment (VTA) is designed to be free-standing when removed from the tractor. When the VTA is not in use, locate a level, dry spot clear of the work zone, position the attachment so that it is accessible from both sides and ensure that the carriers are almost in the closed position. If the cylinder is left in a fully locked position in or out, it will be difficult to install or disconnect the hydraulic lines. With the VTA resting upright and level on the ground disconnect the hydraulic lines at the quick couplers. Drape the loose hydraulic lines and quick couplings over the structure and off the ground. Release the hydraulic retaining pins and articulate the tractor tool carrier/coupler forward and down to release the tool carrier from the attachment hooks.

Vulcan™ Transfer Attachment VTA Maintenance

Periodically inspect the Vulcan Transfer Attachment (VTA) to make sure it has been properly maintained and is not damaged. Failure to perform these periodic maintenance checks may result in damage to the VTA or the Vulcan barrier being moved. On a daily basis, perform the following checks:

- Check that the hydraulic lines and cylinder are in good condition, that all of the fittings are tight, and that there are no leaks.
- Inspect the wheels, axles and bearings. Replace any damaged or bent parts.

After every 10 barrier moves¹, perform the following maintenance activities:

- Lubricate the six 10" x 3" carrier wheels with a grease gun. These bearings have a dust shield and are not sealed against water, the excess grease will act as a seal against moisture.
- Check and clean the wheel treads. Removing debris from the wheel treads will lengthen the life of the wheels and prevent damage to the wheels or the barrier.
- Touch up any scratches in the VTA surface coating with paint to prevent rust

¹ A barrier move is defined as moving 1 km (0.6 mi) of barrier any distance up to a lane width. To determine the maintenance amounts, divide the total length of barrier moved by 1 km (0.6 mi) to determine the number of barrier moves. For example: if 8 km (5.0 mi) of barrier were moved one lane width, this would equal a total of 8 barrier moves.

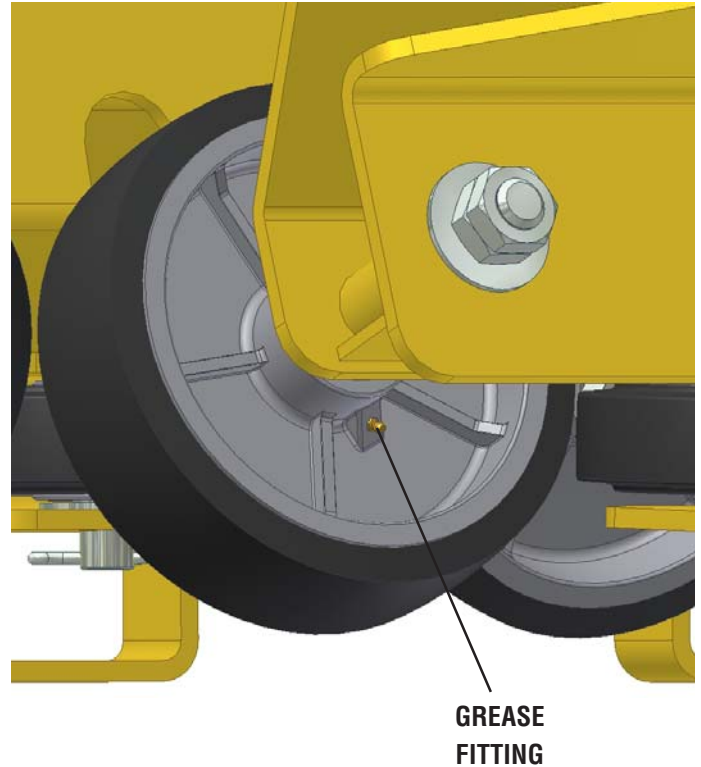

Figure 12

CAUTION! Repair of hydraulic components should only be performed by fully qualified individuals or hydraulic shops. In most cases, the customer should contact Valtir Customer Service Department for advice on repair or replacement of Vulcan Transfer Attachment (VTA) parts. All replacement components must be approved for use or provided by Valtir to guarantee quality and correctness.

Hydraulic system failures can occur in several ways: A gradual or sudden loss of pressure or flow, a loss of power at the pump, or other difficulties. Any of the system's components could be the cause. Start with the checklist below that most applies to the symptom at hand.

Note: Avoid the use of Teflon tape on hydraulic fittings as it can easily jam valves and cause failures in the hydraulic system.

1. ROUGH or ERRATIC SYSTEM OPERATION

- Insufficient or no oil in system: Fill system, check for leaks.
- Oil line restricted, line dirty or collapsed: Clean or replace oil line.
- Worn components (valves, cylinders, etc.): Check for cause of wear. Replace worn parts with correct components.
- Leakage: Check all components, verify tightness of fittings, and inspect hoses for wear while system is idle. Replace damaged hoses or fittings.
- Excessive loading (especially any features not originally installed by Valtir): Remove excessive load.

2. SLOW SYSTEM OPERATION

- Oil viscosity too high or cold oil: Allow oil to warm up before operating or replace with oil intended for correct operating temperature range. See host vehicle operation manual for information on proper oil type.
- Low oil level: Check reservoir and add oil as necessary.
- Air in system: Check for leaks and tighten as necessary. Cycle the system several times to relieve air from system.
- Oil leaks: Tighten fittings, replace seals or damaged lines.
- Worn components (valves, cylinders, etc.): Check for cause of wear. Replace worn parts with correct components.
- Restriction in lines or cylinder check valves: Remove the load on cylinders, clean lines or valves, replace hoses if necessary.

3. LOAD DROPS WHEN SYSTEM IS LOCKED

- Leaking cylinder seals or fittings: Remove the load on cylinders, inspect for damaged hoses or fittings, tighten fittings or replace hoses if necessary.

4. LEAKY CYLINDER(S)

- Seals worn or damaged: Have cylinder repaired by a qualified hydraulics repair shop or replace the cylinder.
- Rod damaged: Have cylinder repaired by a qualified hydraulics repair shop or replace the cylinder.

Limitations and Warnings

The Vulcan Transfer Attachment (VTA) is designed to facilitate the movement of Vulcan Barrier in temporary roadway work zones. To attain the maximum value, safety and performance from your VTA, all of the recommendations and limitations contained in this manual and other supporting documentation must be followed.

Although the VTA is used in work zones to move crashworthy barrier, the VTA itself does not provide impact protection. Because of this, care should be taken when operating the VTA to maintain as much separation between the VTA and its host vehicle and other vehicles in the work zone. Ideally, the VTA and its host vehicle are placed behind the barrier being moved (the non-traffic side), keeping the barrier between the host vehicle and oncoming vehicles. This minimizes the risk of a collision with oncoming traffic and protects the operator of the VTA should an accident occur. In those situations where operation of the VTA on the non-traffic side of the barrier is not possible, every effort should be taken to minimize the risk of accident, such as the use of a shadow vehicle equipped with a Truck Mounted Attenuator (TMA.) See applicable state, federal or other appropriate governmental guidelines in your jurisdiction for specific recommendations on the safe creation, reconfiguration, and removal of work zones.

The VTA is specifically designed to move Vulcan Barrier, manufactured by Valtir. Use of the VTA with other types of barrier or to lift other objects may result in damage to the VTA its host vehicle and / or the barrier and is not recommended. The VTA is also designed to attach to specific makes and models of construction equipment. Use of the VTA with unsupported makes and models of equipment may cause damage to the VTA and / or the host vehicle. Please contact Valtir Customer Service Department to get information on currently supported makes and models of host tractors.

Replacement Parts

For details on replacement parts, refer to the drawing package. The drawings include the part numbers and descriptions. See next page for most likely replacement items. A complete set of replacement wheels can be purchased by ordering the following kit:

SPARE PARTS, VULCAN TRANSFER ATTACHMENT Part number 1200VT-0000

For replacement parts, call customer service: 1-(888)-323-6374.

Vulcan™ Transfer Attachment

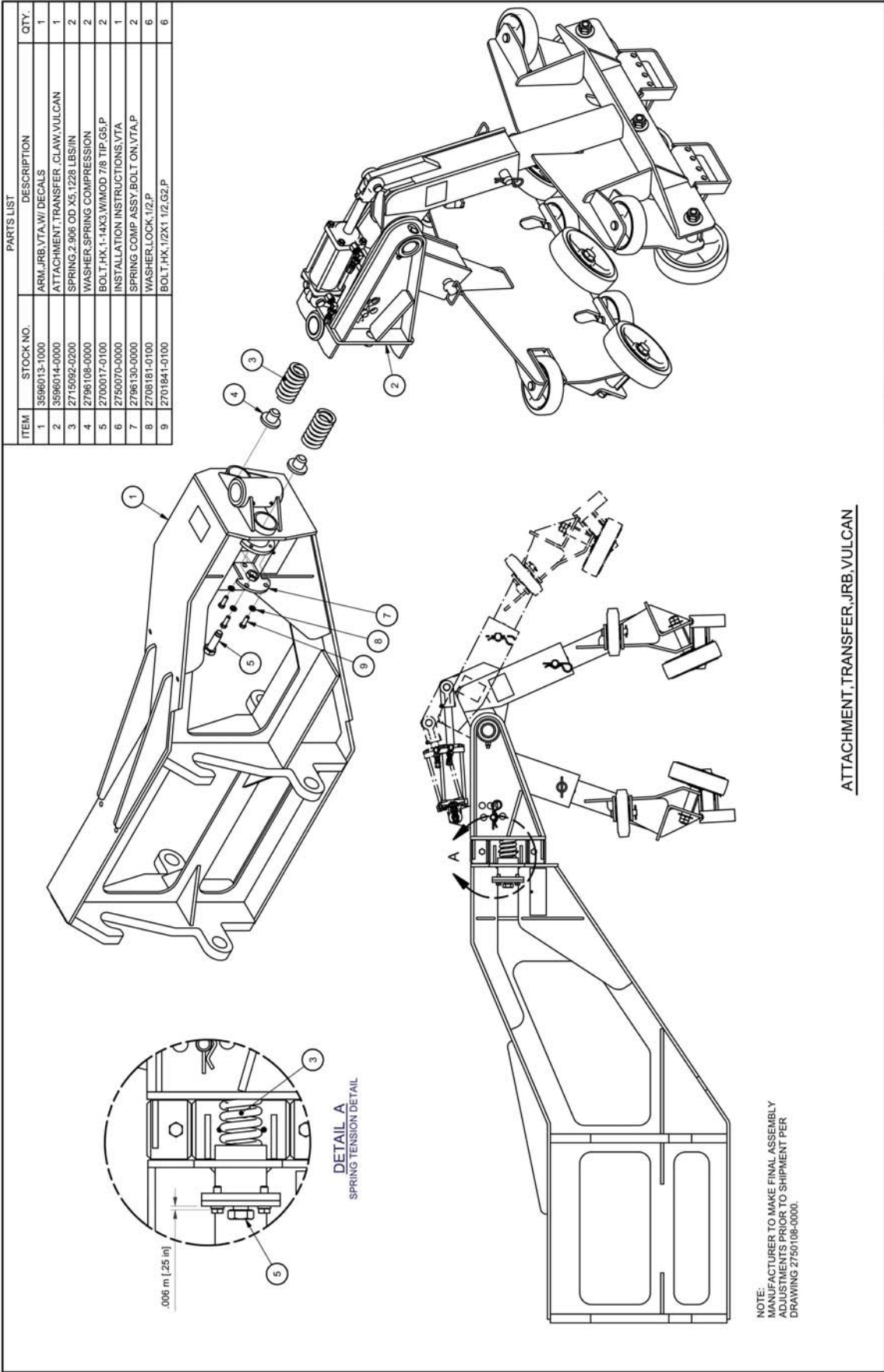

ATTACHMENT, TRANSFER, JRB, VULCAN

ASSEMBLY NO. 3596015-0000 (REF. DWG. 3596015-0000)

Vulcan™ Transfer Attachment

PARTS LIST			
ITEM	STOCK NO.	DESCRIPTION	QTY.
1	3596014-0000	ATTACHMENT, TRANSFER, CLAW, VULCAN	1
2	2715092-0300	SPRING, 2.906 OD, X5, 1228 LBS/IN.Y	2
3	2700017-0100	BOLT, HX, 1-1/4X3, W/MOD 7/8 TIP, G5.P	2
4	2796106-0000	WASHER, SPRING COMPRESSION	2
5	2700019-0000	SUPPORT, MIRROR, 1 ODX11 9/16	1
6	2796104-0000	MIRROR CONVEX, 12X18	1
7	2715822-0000	CLAMP, .28.6mm, QUICK RELEASE	1
9	3596012-1000	ARM, BOBCAT, VTA, W/DECALS	1
12	2750070-0000	INSTALLATION INSTRUCTIONS, VTA	1
13	2735831-3500	MATERIAL SAFETY INFORMATION NOTICE	1
14	2796131-0000	SPRING COMP ASSY, BOLT, T-ON, BOBCAT, VTA	2
15	2708181-0100	WASHER, LOCK, 1/2 P	6
16	2701841-0100	BOLT, HX, 1/2X1 1/2, G2.P	6

DETAIL A
SPRING TENSION DETAIL

NOTE:
MANUFACTURER TO MAKE FINAL ASSEMBLY
ADJUSTMENTS PRIOR TO SHIPMENT PER
DRAWING 2750108-0000.

ATTACHMENT, TRANSFER, BOBCAT, VULCAN

ASSEMBLY NO. 3596018-0000 (REF. DWG. 3596018-0000)

Vulcan™ Transfer Attachment

PARTS LIST			
ITEM	STOCK NO.	DESCRIPTION	QTY.
1	3596019-1000	ARM,CAT,VTA,WIDECALS	1
2	3596014-0000	ATTACHMENT,TRANSFER,CAT,VULCAN	1
3	2700017-0100	BOLT,HX,1-1/4X3,W/NOID 7/8 TIF,G5,P	2
4	2715092-0200	SPRING,2.906 OD X5,1228 LBS/IN	2
5	2796108-0000	WASHER,SPRING,COMPRESSION	2
6	2750075-0000	INSTALLATION INSTRUCTIONS,VTA	1
7	2708181-0100	WASHER,LOCK,1/2 P	6
8	2701841-0100	BOLT,HX,1/2X1 1/2,G2,P	6
9	2796130-0000	SPRING COMP ASSY,BOLT ON,VTA,P	2

DETAIL A
SPRING TENSION DETAIL

.006 in (.25 in)

NOTE:
MANUFACTURER TO MAKE FINAL ASSEMBLY
ADJUSTMENTS PRIOR TO SHIPMENT PER
DRAWING 2750108-0000.

ATTACHMENT,TRANSFER,CAT,VULCAN

ASSEMBLY NO. 3596020-0000 (REF. DWG. 3596020-0000)

Vulcan™ Transfer Attachment

PARTS LIST			
ITEM	STOCK NO.	DESCRIPTION	QTY.
1	2796103-0000	WRIST PIN INTERFACE,VTA	1
2	2796102-0000	RECEIVER ARM,INSIDE,VTA	1
3	2796101-0000	RECEIVER ARM,OUTSIDE,W/FITTING,VTA	1
4	2796110-1000	CYLINDER,4B,6S,MODIFIED	1
5	3596011-0000	CARRIER,WHEEL,ASSY,VTA	2
6	2702221-0100	PIN,HITCH,1X6 1/4 P,W/HAIRPIN COTTER	1
7	2702222-0100	PIN,HITCH,1.14X7 P,W/HAIRPIN COTTER	2
8	2796113-0000	RRO ST 2 1/2X11 1/8,W/HOLES,CHAMFERED,PT	1
9	2696012-0100	BOLT,HX,1/2X5,G8,P	4
10	2704017-0100	RRO ST 2 1/2X12 3/4,W/HOLES,CHAMFERED,PT	4
11	2796111-0000	NUT,LOCK,1/2-13,P	1
12	2715070-0000	HOSE ASSY,HYD,#6 F JIC,#8 M-PIPE,W/ELBOW	2
13	2750661-0000	DECAL,WARNING,HANDS/FEET CLEAR	2

ATTACHMENT,TRANSFER,CLAW,VULCAN

NOTES:
1. PLACE DECALS APPROXIMATELY AS SHOWN.

ASSEMBLY NO. 3596014-0000 (REF. DWG. 3596014-0000)

Vulcan™ Transfer Attachment

ITEM	STOCK NO.	DESCRIPTION	QTY.
1	2796105-0000	ARM,CARRIER,WHEEL,VTA	1
2	2700016-0100	BOLT,HX,1-14X9,GS,P	3
3	2708062-0100	WASHER,FLAT,1/8X1 1/16 ID X2 1/2 OD,P	7
4	2704052-0100	NUT,HX,1-14X35/64,GS,P	6
5	2702004-0100	PIN,CLEVIS,1X4,P	4
6	2796106-0000	WHEEL,10X3,1800LBS	3
7	2796107-0000	WHEEL,8X2,1000LBS	4
8	2702151-0100	PIN,COTTER,3/16X1 1/2,P	4

PART NUMBER: 3596011-0000
 PART NAME: SEE PARTS LIST
 TOLERANCES: TOL DIMENSIONAL: ± 1/16
 TOL DECIMAL: .XX ± .01
 TOL ANGULAR: ± .005
 TOL SURFACE: .005
 UNLESS OTHERWISE SPECIFIED

DO NOT SCALE DRAWING

CARRIER,WHEEL,ASSY,VTA

NOTES:
 1. SEE INSTALLATION MANUAL (PIN: 2750070-0000) FOR WHEEL ASSEMBLY INSTRUCTIONS.

ASSEMBLY NO. 3596011-0000 (REF. DWG. 3596011-0000)

Notes

Vulcan™ Transfer Attachment

Notes

Notes



For more complete information on Valtir products and services, visit us on the web at www.valtir.com. Materials and specifications are subject to change without notice. Please contact Valtir to confirm that you are referring to the most current instructions.

WWW.VALTIR.COM
1.888.323.6374