



# RAPTOR<sup>®</sup>

## CRASH CUSHION

By Valmont Highway

## PRODUCT MANUAL



## TABLE OF CONTENTS

1.0	RAPTOR™ Introduction.....	3
2.0	System Overview.....	3
3.0	Limitations and Warnings.....	3
4.0	Before Installation.....	4
5.0	Safety Statements.....	4
6.0	Design Considerations.....	5
7.0	System Design.....	5
8.0	Parts Identification.....	7
9.0	Installation Preparation.....	8
10.0	Bill of Materials.....	8
11.0	Installation Instructions.....	9
12.0	Installation Examples.....	12
13.0	Maintenance and Repair.....	13
14.0	Installation Checklist.....	14
15.0	Frequently Asked Questions.....	15
16.0	RAPTOR™ Removal Procedure.....	16
17.0	RAPTOR™ Removal Instructions.....	17



## APPENDIX 2 – TECHNICAL DRAWINGS

18.0	RAPTOR™ 300.....	20
19.0	RAPTOR™ 600.....	21

## 1.0 INTRODUCTION

RAPTOR™ is a compact crash cushion made from durable HDPE which can be installed at many sites, otherwise regarded as lacking in space to protect in the traditional manner. The system consists of 2 pieces which connect together and provide protection from a rigid object which is positioned in the central void.

The system has been designed and tested to meet the evaluation criteria of both MASH TL1 and NCHRP 350 Test Level 1 for a crash cushion.

The RAPTOR™ is a free standing low cost crash cushion and is not anchored in anyway.

The RAPTOR™ is available in either black or yellow.

## 2.0 SYSTEM OVERVIEW

RAPTOR™ is designed and constructed to provide acceptable structural adequacy, minimal occupant risk and safe trajectory as set forth in NCHRP 350 and MASH TL1 Crash Cushions.

When impacted with an 1100kg and 2270kg vehicle at speeds of 31 mph (50kph) and side on entry angles up to 15 degrees, the impacting vehicle is contained in a safe manner.

RAPTOR™ offers exceptional vehicle control and energy absorbing capabilities in head on impacts, where the energy is absorbed by internal plastic cartridges. It is also capable of re-directing a vehicle in side on angled impacts. See separate Impact Absorption Explanation for more details.

## 3.0 LIMITATIONS AND WARNINGS

RAPTOR™ has been rigorously tested and evaluated per the evaluation criteria in the MASH TL1 and NCHRP 350 guidelines for gating crash cushions. The impact conditions recommended in MASH TL1 and NCHRP 350 are intended to address typical in-service collisions.

RAPTOR™ systems allow an impacting vehicle to be contained in a safe and predictable manner under the MASH TL1 and NCHRP 350 impact conditions. It is imperative that the system is installed as per manufacturers' specification.

Vehicle impacts that vary from the MASH TL1 or NCHRP 350 impact conditions described for crash cushions may result in significantly different results than those experienced in testing. Vehicle impact characteristics different than, or in excess of, those encountered in MASH TL1 or NCHRP 350 testing (weight, speed and angle) may result in system performance that may not meet the MASH TL 1 or NCHRP 350 evaluation criteria.



2000kg Pick-up truck impacting head-on with a pole using the RAPTOR™ at 31mph (50kph)

## 4.0 BEFORE INSTALLATION

Design, selection and placement of the RAPTOR™ must be in accordance with the Road Controlling Authority's guidelines and the details shown in the construction drawings. Installation must be in accordance with the installation instructions supplied for this product.

Depending on the application and circumstances at the site, installation and assembly of the system should take a two person crew less than 30 minutes.

RAPTOR™ is a highly engineered safety device made up of a small number of parts. Before starting installation ensure that one is familiar with the make-up of the system.



## 5.0 SAFETY STATEMENTS

### General Safety

- All required traffic safety precautions should be complied with. All workers should wear required safety clothing. (Examples, and not limited to, include: high visibility vests, safety helmet, steel capped footwear, gloves etc.)
- Only Authorised trained personnel should operate any machinery. Where overhead machinery is used, care must be taken to avoid any overhead hazards.
- Gloves should be worn at all times.

### Raptor™ Safety Statements

- Each shell weighs 242 pounds (110kg) so lifting is conducted using suitable machinery and equipment. A crane truck or fork hoist is recommended to lift the shells, and **always use the centrally located lifting eye** to attach the rigging. Tag lines can be attached to the lifting eye or side connection bolts.
- DO NOT attempt to lift using lifting straps around the HDPE shell as the plastic is slippery and straps may slide off.
- Avoid placing hands or fingers in and around moving parts when components are being lifted and manoeuvred into place. (i.e. around connection holes etc.)



**At NO time is it required that personnel need to work at height or have suspended loads pass overhead. It is recommended that personnel are as many feet away from the suspended load as it is lifted.**



## 6.0 DESIGN CONSIDERATIONS

### 6.1 Undulating Ground Conditions

Site specific grading may be necessary to ensure that there are no 'humps' or 'hollows' that may significantly alter the impacting vehicles stability. It is preferred that the RAPTOR™ is installed on flat level ground. The area around the hazard must be level for a 5 foot (1500mm) cord when pulled along the centreline of the hazard. (Shown in Figure A).



Figure A

### 6.2 Kerbs & Slopes

As with all road side safety hardware, RAPTOR™ has been designed and tested so that the centre of gravity of the impacting vehicle is at or near the same height as middle of the system. For this reason, it is preferred that kerbs or channels are not installed in front of the system as they will result in altering the height of the vehicle at impact. If there is no option but to install near a kerb advice should be followed from the Road Controlling Authority's guidelines.

If the device is to be installed lower than road level itself, this distance cannot be greater than 4 inches (100mm) (shown in Figure B).

If installed on a raised bed, maximum recommended bed height is 6 inches (150mm).

A maximum slope of 10:1 is preferable. On slopes greater than this, advice should be followed from the Road Controlling Authority's guidelines (shown in Figure C).

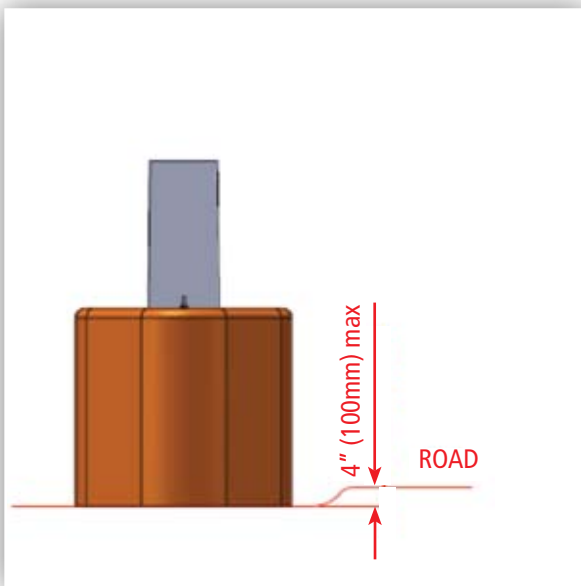

Figure B

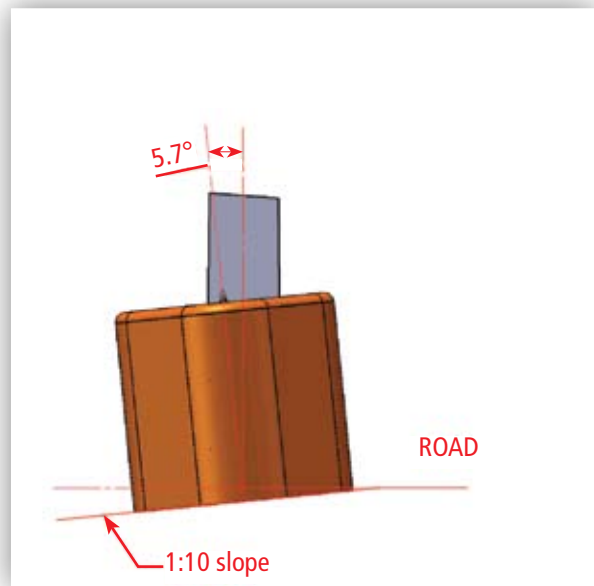

Figure C

## 7.0 SYSTEM DESIGN

### 7.1 Orientation

The installation orientation is always tangent/parallel to the direction vehicles are travelling (shown in Figure D).

### 7.2 Hazard Size

There are two RAPTOR™ systems available called the 300 and 600. The void sizes are the only difference between them and they measure 12 x 23 inches (300mm x 590mm), and 24 x 23 inches (600mm x 590mm) respectively (shown in Figures E & F).

When choosing which system to use, ensure that the void size is sufficient size and allows the device to be installed with the correct orientation.

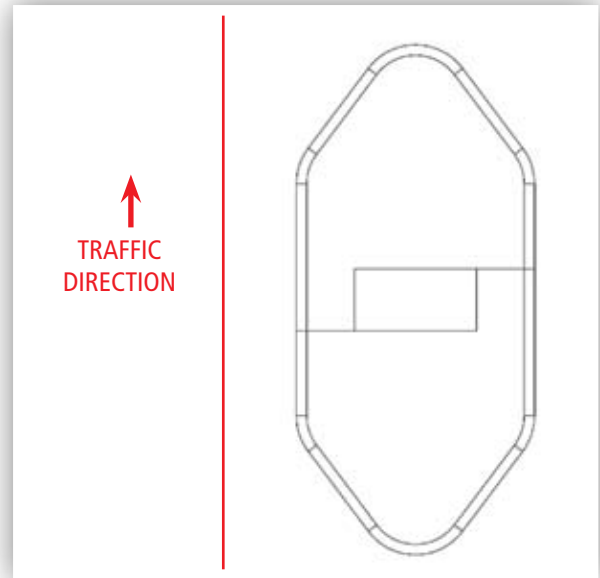

Figure D

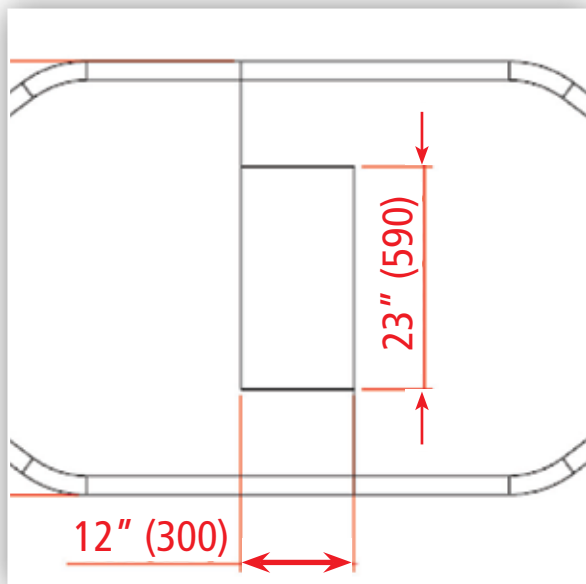

Figure E

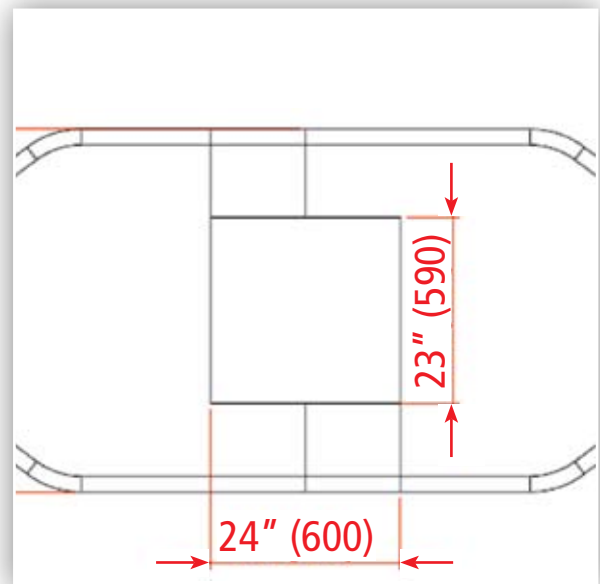

Figure F

## 8.0 RAPTOR™ - PARTS IDENTIFICATION



Shell



Packer Pieces



Short Connector



Long Connector



Bolt & Washer

All steel components used in the RAPTOR™ are hot dipped galvanized.

## 8.1 Delineation Examples



Top Mounted



Side Mounted



**Delineation must be glued. Screws and rivets are not acceptable.**

**Note:** Substrate used for the delineation should have a maximum thickness of 0.47 inches (1.2mm) so to not interfere with the performance of the system.

The recommended glue is a fast curing polyurethane constructive adhesive such as Sika SuperGrip® 30 minute. For this product and any alternative brands used, make sure one is familiar with the hazards associated with the adhesive which are outlined on the product itself.

## 9.0 RAPTOR™ INSTALLATION PREPARATION

---

### 9.1 Getting Started

Determine which RAPTOR™ system is best suited to fit the object being protected. Refer to Hazard Size in the System Design section of this manual for more information on the void size of the RAPTOR™ 300 and 600 systems.

### 9.2 Preparation

Before installing a RAPTOR™, ensure that all components required for the system are on site and have been identified. RAPTOR™ is a highly engineered safety device made up of a small number of parts. Before starting installation ensure that one is familiar with the make-up of the system. Refer to the Parts Identification and Bill of Materials section in this manual for more information..

### 9.3 Tools Required

The tools required to install RAPTOR™ are:

- A crane truck or fork hoist
- Suitable lifting equipment (including guy ropes) that can connect to the lifting eye
- 32mm socket and a minimum 2 inch (50mm) extension
- Pry bar
- 2 ton ratchet tie down (commonly used to strap freight down on trucks)

## 10.0 RAPTOR™ BILL OF MATERIALS

---

### RAPTOR™ 300

- 2 x Shells
- 10 x Short Connectors
- 20 x Bolt & Washers

### RAPTOR™ 600

- 2 x Shells
- 2 x Packers
- 10 x Long Connectors
- 20 x Bolts & Washers



## 11.0 RAPTOR™ INSTALLATION INSTRUCTIONS

### 11.1 Step 1 – Site Preparation

Site specific grading may be required to ensure that the RAPTOR™ is installed on flat, compact, level ground. Refer to Undulating Ground Conditions and Slopes & Kerbs in the Design Considerations section of this manual for more information.



Figure 1



Figure 2

### 11.2 Step 2 – Installing the Shells



**Before unloading the shells ensure that the operation of the lifting device is well clear of any overhead hazards**

**Always attach the lifting equipment to the lifting eye located on the top of each shell. The tag line can be connected to the same lifting eye or the bolts located on the side.**

Using a crane truck or fork hoist, lift the first shell into the approximate finished position (shown in Figure 1). Then repeat for the second shell (shown in Figure 2).

**Note:** The shell orientation is always parallel to the direction of traffic flow.

Final positioning can be done using a pry bar (shown in Figure 3).



Figure 3

### 11.3 Step 3 – Installing the Shells

Using a 2 ton ratchet tie down (or similar), pull the two RAPTOR™ shells tightly together and align vertically using a pry bar (shown in Figure 4).



Figure 4

If the larger 600 system is being installed, fit the packer piece first. The notches face towards the outside (shown in Figure 5).



Figure 5

Hold the connector bars in place and fix to the shells using two M16 x 40mm hex head bolts and washers (shown in Figure 6).

**Note:** Different length connectors are required for each system and the details of each can be found in the Parts identification section of this manual.

Repeat until all 10 connectors required are attached (5 on each side).

Tighten all bolts with a socket to complete the installation and remove the ratchet tie down (shown in Figure 7).



Figure 6



Figure 7

#### 11.4 Step 4 – Delineation

Delineation must be attached to the RAPTOR as required by the Road Controlling Authority.

Further details can be found in the Delineation section in this product manual.



Delineation examples: Top Mounted and Side Mounted

## 12.0 RAPTOR™ INSTALLATION EXAMPLES



**RAPTOR™ 300**



**RAPTOR™ 600**

## 13.0 RAPTOR™ MAINTENANCE AND REPAIR

### 13.1 Maintenance

RAPTOR™ systems are maintenance free. It is however recommended that a periodic inspection is carried out on the crash cushion to check:

- The systems are positioned as intended
- The bolts fixing the connectors to the shells are spanner tight
- The components have not been damaged in any way that may affect the performance

**Note:** After approx 25 years\* it is expected that the RAPTOR™ will need to be replaced as that is the expected 'useful' lifespan of the plastic used. (\* May vary due to location)

### 13.2 Repair

#### Recommended tools:

- A crane truck or fork hoist
- Suitable lifting equipment (including tag lines) that can connect to the lifting eye
- 32mm socket and a minimum 2 inch (50mm) extension
- Pry bar
- 2 ton ratchet tie down (commonly used to strap freight down on trucks)

#### Replacement parts that may be required after impact:

- Shells
- Packers (if a 600 system)
- Bolts, Washers and Connectors (Connector size is different for the 300 & 600 system)

#### Key Steps:

- Separate the components by undoing the bolts and removing the connectors

**Note:** If the bolts can't be removed, the sections which house the connection recesses can easily be cut from the main body of the shell using a hand saw or 'other' similar device. Ensure that all safety measures are adhered to for the equipment being used.

- Assess which components are damaged and replace with new parts accordingly
- Re-assemble as per the Installation Instructions in this manual.



After a head on impact



After a re-direct impact

**14.0 Installation Checklist for RAPTOR™ 300 and 600 SYSTEMS**

Location: \_\_\_\_\_

Installed By: \_\_\_\_\_

Date: \_\_\_\_\_

Signed: \_\_\_\_\_

Inspected By: \_\_\_\_\_

Date: \_\_\_\_\_

Signed: \_\_\_\_\_

**General**

Ground is level for a 5 foot (1500mm) cord when pulled along the centreline of the hazard.	<input type="checkbox"/> Yes	<input type="checkbox"/> No
RAPTOR™ is oriented to face direction of traffic (see below).	<input type="checkbox"/> Yes	<input type="checkbox"/> No
Attach delineation as required by the Road Controlling Authority.	<input type="checkbox"/> Yes	<input type="checkbox"/> No

**RAPTOR™ 300**

The Short Connectors are installed and bolts tight.	<input type="checkbox"/> Yes	<input type="checkbox"/> No
---	------------------------------	-----------------------------

**RAPTOR™ 600**

The Packer is placed between the Shells correctly.	<input type="checkbox"/> Yes	<input type="checkbox"/> No
The Long Connectors are installed and bolts tight.	<input type="checkbox"/> Yes	<input type="checkbox"/> No

Comments:

\_\_\_\_\_

\_\_\_\_\_

\_\_\_\_\_

\_\_\_\_\_

\_\_\_\_\_

\_\_\_\_\_

\_\_\_\_\_

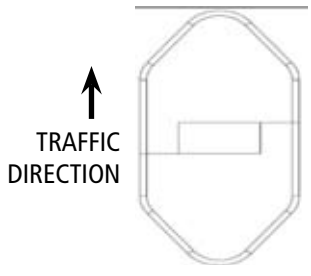

**Disclaimer:**  
Important Note: The conformity of the installation is the responsibility of the installation contractor, and Valmont Highway accepts no liability for or in connection with any installation that is outside of the specifications of this manual or the Road Controlling Authority. For more information, please refer to our Standard Terms and Conditions of Sale available on our website: [www.ingalcivil.com.au](http://www.ingalcivil.com.au).

## 15.0 RAPTOR™ FREQUENTLY ASKED QUESTIONS

**1. What type of equipment is required to install the RAPTOR™?**

A shell weighs 110kg so a crane truck or fork hoist is required to move them into place. Standard tools for installation include a 32mm socket with a minimum 2 inch (50mm) extension, a 2 tonne ratchet tie down and a pry bar.

**2. Does RAPTOR™ require a specific foundation?**

No, it can be installed on concrete, asphalt or suitable compacted fill material.

**3. Does your company provide spare parts and what is the lead-time?**

Components are normally ex stock and can be shipped within 24 hours or an accepted order.

**4. On average, how long does it take to install a RAPTOR™?**

Installation and assembly of a system should take a two person crew less than 30 minutes.

**5. Can the RAPTOR™ be easily damaged by vandalism?**

The shells are made of HDPE so the system is very difficult to graffiti. In addition the bolts used to hold the shells together are recessed so a special socket is required to remove them.

**6. Does the RAPTOR™ have to be positioned a certain way.**

Yes, it must always be parallel to the direction of travel.

**7. How easily can the RAPTOR™ be restored after impact?**

It is a modular system and is easily fixed with new components in less than 30 minutes.

**8. What is the largest obstacle that can be protected?**

RAPTOR™ 600 has the largest internal void measuring 23 x 24 inch (590mm x 600mm).

**9. What maintenance is required?**

RAPTOR™ is a maintenance free system.

**10. What is the RAPTOR™ attached to?**

It is free-standing and not connected to the object it is shielding or the ground.

**11. Is the product UV stabilised? How long is the expected lifespan?**

Yes, RAPTOR™ shell and packer contains a fully formulated UV stabilisation package. The expected 'useful' performance life of RAPTOR™ is 25 years.

See separate Assessment of Materials report for more details.

**12. Is RAPTOR™ made of flammable material?**

Yes, the material used in a RAPTOR™ is flammable if there is a SIGNIFICANT flame source. Other roadside safety devices are made of similar materials and this level of flammability is not considered an issue.

See separate Assessment of Materials report for more details.

If a system is damaged by fire all damaged components should be replaced at the first available opportunity as outlines in the Repair section of this manual.



## 16.0 RAPTOR™ REMOVAL PROCEDURE

### 16.1 Tools Required

The tools required to remove RAPTOR™ are:

- A crane truck or fork hoist
- Suitable lifting equipment (including guy ropes) that can connect to the lifting eye
- 32mm socket and a minimum 2 inch (50mm) extension
- Pry bar
- 2 ton ratchet tie down (commonly used to strap freight down on trucks)

### 16.2 Safety Statements

#### General Safety

All required traffic safety precautions should be complied with. All workers should wear required safety clothing (high visibility vests, steel capped footwear, gloves, hard hats, safety glasses etc.).

Only authorised trained personnel should operate any machinery. Where overhead machinery is used, care must be taken to avoid any overhead hazards.

Gloves should be worn at all times.

#### Raptor™ Safety Statements

Each shell weighs 242 pounds (110kg) so lifting of the shells must not be attempted manually. Only use a crane truck or fork hoist to lift the shells and always use the lifting eye. DO NOT attempt to lift using lifting straps around the plastic shell as the plastic is slippery and straps may slide off.

Avoid placing hands or fingers in and around moving parts when components are being lifted and manoeuvred into place. (I.e. around joiner holes, etc).

Do not stand on top of the shells to assist in installation at any time.

### 16.3 Bill of Materials

#### Raptor™ 300

- 2 x Shells
- 10 x Short connectors
- 20 x Fixings

#### Raptor™ 600

- 2 x Shells
- 2 x Packers
- 10 x Long connectors
- 20 x Fixings



Installed Raptor™ 300



Installed Raptor™ 600



## 17.0 RAPTOR™ REMOVAL INSTRUCTIONS

### 17.1 Step 1 for Raptor™ 300 Disconnecting Shells (No packer piece)

Prior to disconnecting the Shells, the orientation of the existing Raptor device shall be noted and photographed. This is to ensure that if the Raptor is to be reassembled after temporary disconnection it is installed in its correct orientation, i.e. parallel to the direction the vehicles are travelling.

 **Note the Raptor™ shall not be attached to the hazard it is protecting OR anchored to the ground in any way.**

- a) Using a ratchet, 32mm socket and extension loosen the M16 x 40mm hex head bolts located on both connection sides of the Raptor (Figure 8).

Repeat for all 20 bolts, 10 on each side

- b) Unscrew all bolts and remove all short connector bars (Figure 9).
- c) The Raptor™ should now look like Figure 10.



Figure 8



Figure 9

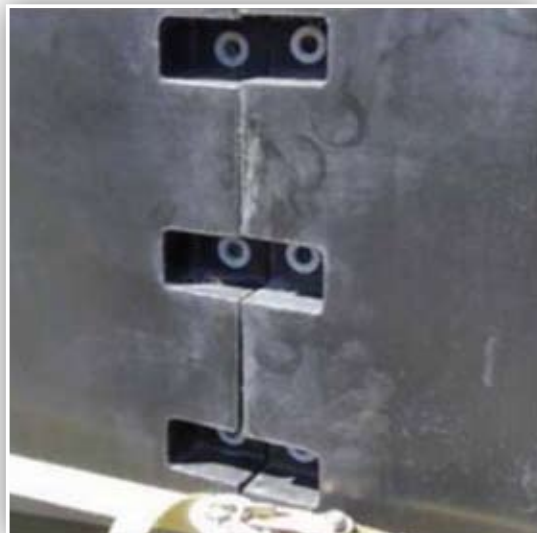

Figure 10

## 17.2 Step 1 for Raptor™ 600

### Disconnecting Shells (No packer piece)

Prior to disconnecting the Shells, the orientation of the existing Raptor device shall be noted and photographed. This is to ensure that if the Raptor is to be reassembled after temporary disconnection it is installed in its correct orientation, i.e. parallel to the direction the vehicles are travelling.



**Note the Raptor™ shall not be attached to the hazard it is protecting OR anchored to the ground in any way.**

- a) Using a ratchet, 32mm socket and extension loosen the M16 x 40mm hex head bolts located on both connection sides of the Raptor™ (Figure 11).

Repeat for all 20 bolts, 10 on each side.

- b) Unscrew all bolts and remove all long connector bars. Use a 2 ton ratchet pulling both shells together for better alignment if bolts and connectors become difficult to remove (Figure 12).

- e) Remove packer pieces (Figure 13).



Figure 11



**Note: The Raptor 300 shown above is for illustration purpose only however procedure remains the same for the 600 model.**



Figure 12



Figure 13

### 17.3 Step 2 – Shell Removal (Common for Raptor™ 300 & Raptor™ 600)

Disconnection and removal of Raptor should take a two person crew less than half an hour as indicated in the “Installation and Product Manual: Raptor™”.

- a) Depending on whether the unit is required to be fully removed or only shifted enough to allow access to the hazard being protected, a pry bar can be used to shift the shells out of place to allow room for access to hazard being protected (Figures 14 and 15).
- b) For full removal use a crane truck or fork hoist to lift the Raptor™ shells away to the desired location (Figure 16). Be careful of overhead cables and ensure a hard hat is worn during the lifting process.
- c) Smooth and level the ground around where the Raptor™ has been installed (Figure 17).



Figure 14



Figure 15



Figure 16



Figure 17

### 17.4 Step 3 – Shell Reassembly

To re-assemble the Raptor™ refer to the section “11.0 - INSTALLATION INSTRUCTIONS” of this manual. Also, photograph the reassembled Raptor and forward a copy to the controlling road authority.

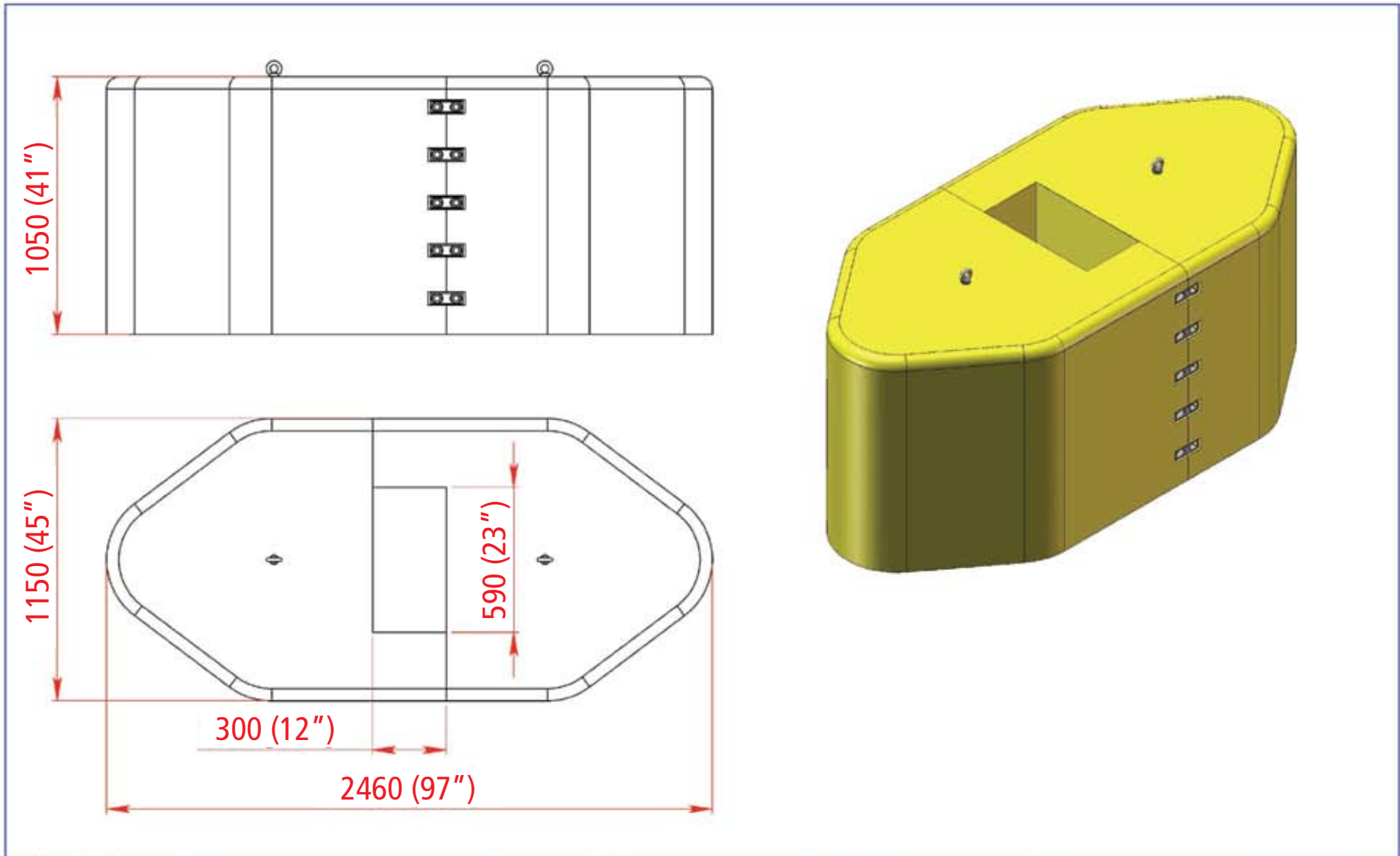

The information herein is proprietary to Amorflex International Ltd. and shall not be disclosed, duplicated or used otherwise without the express written approval of Amorflex International Ltd. © 2011 Amorflex International Ltd.			SCALE: 1:20			Standard Tolerance				
				DRAWN BY	10/12/2007			LW	SHEET	DRAWING NUMBER
				APPR'D BY	10/12/2007	DJ	1 OF 1	A10340	A	
	A	INITIAL ISSUE	10/12/2007	RAPTOR™ 300						
REV.	CHANGES	DATE								

19.0 RAPTOR™ 600 (24" X 23" Void) (600mm x 590mm Void)

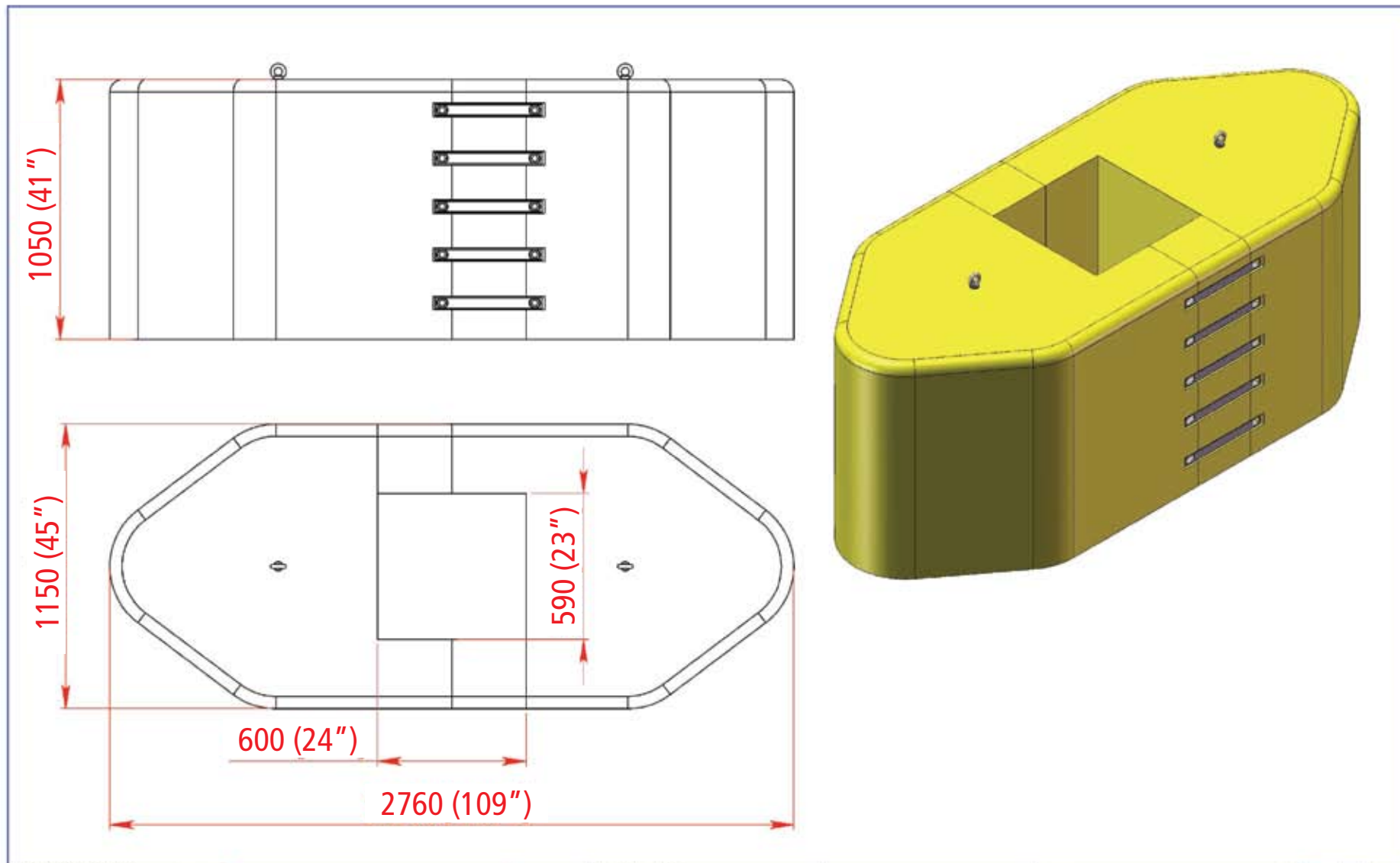

The information herein is proprietary to Armorflex International Ltd and shall not be disclosed, duplicated or used otherwise without the express written approval of Armorflex International Ltd.			SCALE: 1:20			Standard Tolerance		
				DATE	INIT.			
			DRAWN BY	10/12/2007	LW			
			APPR'D BY	10/12/2007	DJ			
© 2011 Armorflex International Ltd.	REV. A	INITIAL ISSUE	CHANGES	DATE	10/12/2007	RAPTOR™ 600		
						SHEET	DRAWING NUMBER	REV.
						1 OF 1	A10341	A

NOTES

Handwritten notes in blue ink on lined paper. The notes are organized into a table with 4 columns and 8 rows. The columns are labeled 'DATE', 'MILEAGE', 'MILES TO FILL', and 'REMARKS'. The entries describe fuel usage for two vehicles, 'H221' and 'H222', with specific dates and distances.

DATE	MILEAGE	MILES TO FILL	REMARKS
03-18-2011	140	30	H221
03-25-2011	120	40	H221
04-15-2011	140	30	H222
04-22-2011	120	40	H222
05-02-2011	140	30	H221
05-09-2011	120	40	H221
05-16-2011	140	30	H222
05-23-2011	120	40	H222





For more complete information on Valtir products and services, visit us on the web at [www.valtir.com](http://www.valtir.com). Materials and specifications are subject to change without notice. Please contact Valtir to confirm that you are referring to the most current instructions.

**[WWW.VALTIR.COM](http://WWW.VALTIR.COM)**  
**1.888.323.6374**

