



Triton Barrier[®] For TL-1 Applications

WATER FILLED BARRIER

ASSEMBLY MANUAL

Triton Barrier[®] For TL-1 Applications

Assembly Manual



15601 Dallas Parkway
Suite 525
Addison, Texas 75001



Important: These instructions are to be used only in conjunction with the assembly, maintenance, and repair of the Triton Barrier[®] system. These instructions are for standard assembly specified by the appropriate highway authority only. In the event the specified system assembly, maintenance, or repair would require a deviation from standard assembly parameters, contact the appropriate highway authority engineer. This system has been accepted for use by the Federal Highway Administration for use on the national highway system under strict criteria utilized by that agency. Valtir representatives are available for consultation if required.

This Manual must be available to the worker overseeing and/or assembling the product at all times. For additional copies, contact Valtir at (888) 323-6374 or download from websites below.

The instructions contained in this Manual supersede all previous information and Manuals. All information, illustrations, and specifications in this Manual are based on the latest Triton Barrier[®] system information available to Valtir at the time of printing. We reserve the right to make changes at any time. Please contact Valtir to confirm that you are referring to the most current instructions.

Table of Contents

Customer Service Contacts	3
Important Introductory Notes	3
Recommended Safety Rules for Assembly	4
Safety Symbols	5
Warning and Cautions	5
Limitations and Warnings.....	6
Important Introductory Notes	7
Special Site Considerations	8
Preparation.....	9
Recommended Tools and Equipment:.....	9
Deployment and Retrieval.....	10
Checking the Assembly.....	11
Retrieval.....	11
Storing.....	12
Maintenance and Repair.....	13
Visual Drive-By Inspection	13
Walk-up Inspection.....	13
Triton Barrier® Patching Preparation	14
Deflection/Clear Zone	17
Triton Barrier® Expected Deflection Ranges	18

Customer Service Contacts

Valtir is committed to the highest level of customer service. Feedback regarding the Triton Barrier® system, its assembly procedures, supporting documentation, and performance is always welcome. Additional information can be obtained from the contact information below:

Valtir:

Telephone:	(888) 323-6374 (USA Only) (214) 589-8140 (USA or International)
Contact Link:	www.Valtir.com/Contact
Internet:	www.Valtir.com

Important Introductory Notes

Proper assembly of the Triton Barrier® system is essential to achieve performance of the system under appropriate federal and state criteria. These instructions should be read in their entirety and understood before assembling the Triton Barrier® system. These instructions are to be used only in conjunction with the assembly of the Triton Barrier® system and are for standard assemblies only as specified by the applicable highway authority. In the event your system assembly requires or involves deviation from standard parameters or, during the assembly process a question arises, please contact the appropriate highway authority that specified this system at this particular location for guidance. Valtir is available for consultation with that agency. These instructions are intended for an individual who is qualified to both read and accurately interpret them as written. They are intended for the individual who is experienced and skilled in the assembly of highway products which are specified and selected by the highway authority.

A set of product and project shop drawings will be supplied by Valtir. The shop drawings will be for each section of the assembly. These drawings should be reviewed and studied thoroughly by a qualified individual who is skilled in interpreting them before the start of any assembly.



Important: Read safety instructions thoroughly and follow the assembly directions and suggested safe practices before assembling, maintaining, or repairing the Triton Barrier® system. Failure to follow this warning can result in serious injury or death to workers and/or bystanders. It further compromises the acceptance of this system by the FHWA. Please keep these instructions for later use.



Warning: Ensure that all of the Triton Barrier® system Warnings, Cautions, and Important statements within the Triton Barrier® Manual are completely followed. Failure to follow this warning could result in serious injury or death in the event of a collision.

Recommended Safety Rules for Assembly

*** Important Safety Instructions ***

This Manual must be kept in a location where it is readily available to persons who are skilled and experienced in the assembly, maintenance, or repair of the Triton Barrier® system. Additional copies of this Manual are immediately available from Valtir by calling (888) 323-6374 or by visiting Valtir.com. This Manual may also be downloaded directly from the websites indicated below. Please contact Valtir if you have any questions concerning the information in this Manual or about the Triton Barrier® system.

Always use appropriate safety precautions when operating power equipment, and when moving heavy equipment or the Triton Barrier® components. Gloves, safety goggles, steel toe boots, and back protection shall be used.

Safety measures incorporating traffic control devices specified by the highway authority must be used to provide safety for personnel while at the assembly, maintenance, or repair site.

Safety Symbols

This section describes the safety symbols that appear in this Triton Barrier® Manual. Read the Manual for complete safety, assembly, operating, maintenance, repair, and service information.

Symbol Meaning



Safety Alert Symbol: Indicates Danger, Warning, or Caution. Failure to read and follow the Danger, Warning, Safety, or Caution indicators could result in serious injury or death to the workers and/or bystanders.

Warning and Cautions

Read all instructions before assembling, maintaining, or repairing the barrier system.



Warning: Do not assemble, maintain, or repair the barrier system until you have read this Manual thoroughly and completely understand it. Ensure that all Warnings, Cautions, and Important statements within the Manual are completely followed. Please call Valtir at (888) 323-6374 if you do not understand these instructions. Failure to follow this warning could result in serious injury or death in the event of a collision.



Warning: Safety measures incorporating appropriate traffic control devices specified by the highway authority must be used to protect all personnel while at the assembly, maintenance, or repair site. Failure to follow this warning could result in serious injury or death in the event of a collision.



Warning: Use only Valtir parts that are specified herein for the Triton Barrier® TL-1 for assembling, maintaining, or repairing the Triton Barrier® system. Do not utilize or otherwise comeingle parts from other systems even if the systems are other Valtir systems. Such configurations have not been tested, nor have they been accepted for use. Assembly, maintenance, or repairs using unspecified parts or accessories is strictly prohibited. Failure to follow this warning could result in serious injury or death in the event of a vehicle impact with an UNACCEPTED system.



Warning: Do NOT modify the barrier system in any way. Failure to follow this warning could result in serious injury or death in the event of a collision.



Warning: Ensure that the barrier system and delineation used meet all federal, state, specifying agency, and local specifications. Failure to follow this warning could result in serious injury or death in the event of a collision.



Warning: Ensure that your assembly meets all appropriate Manual on Uniform Traffic Control Devices (MUTCD) and local standards. Failure to follow this warning could result in serious injury or death in the event of a collision.

Limitations and Warnings

Valtir, in compliance with the National Cooperative Research Highway Program 350 (NCHRP Report 350) “Recommended Procedures for the Safety Performance of Highway Safety Features”, contracts with FHWA approved testing facilities to perform crash tests, evaluation of tests, and submittal of results to the Federal Highway Administration for review.

The Triton Barrier® system was tested to meet the impact criteria, requirements and guidelines of NCHRP Report 350. These tests, specifically set forth by FHWA, evaluate product performance by simulating those impacts outlined by NCHRP Report 350 involving a typical range of vehicles on our roadways, from lightweight cars (approx. 820kg [1800 lb.]) to full size pickup trucks (approx. 2000 kg [4400 lb.]) as specified by the FHWA. A product can be certified for multiple Test Levels. The Triton Barrier® is certified to the Test Level(s) as shown below:

Test Level I: 50 km/h [31 mph]

These FHWA directed tests are not intended to represent the performance of systems when impacted by every vehicle type or every impact condition existing on the roadway. This system is tested only to the test matrix criteria of NCHRP 350 as approved by FHWA.

Valtir does not represent nor warrant that the results of these controlled tests show that vehicle impacts with the products in other conditions would necessarily avoid injury to person(s) or property. Impacts that exceed the specifications of the system may not result in acceptable crash performance as outlined in NCHRP Report 350, relative to structural adequacy, occupant risk and vehicle trajectory. Valtir expressly disclaims any warrant or liability for injury or damage to persons or property resulting from any impact, collision, or harmful contact with products, other vehicles, or nearby hazards or objects by any vehicle, object or person, whether or not the products were by third parties.

The Triton Barrier® system is intended to be deployed, delineated, and maintained in accordance with specific state and federal guidelines. Valtir offers a reflective delineator panel and has reflective tabs for its Triton Barrier® line of products. However, the material is only intended to supplement delineation required by the Department of Transportation’s “Manual on Uniform Traffic Control Devices” (MUTCD). Design tables are provided in this Manual to aid in selecting the most appropriate product configuration for proper application to the site. The appropriate highway authority approved engineer should be careful to properly select, assemble, and maintain the product. Careful evaluation of the site geometry, vehicle population type, speed, traffic direction and visibility are some of the elements that require evaluation the proper selection of a safety appurtenance by the appropriate specifying highway authority.

After an impact occurs, the product must be repaired to its original condition as soon as possible. When a safety product is impacted, it is mandatory that the highway authority inspect all the components for damage and replace/repair components as necessary. If the system is not repairable, a complete system replacement is required.

Important Introductory Notes

Proper deployment and maintenance of the Triton Barrier® system is critical to achieve performance under appropriate state and federal guidelines. Take the time to review this Manual including the Limitations and Warnings section thoroughly before performing the necessary work. Do not attempt to assemble any longitudinal Triton Barrier® without the proper plans and assembly Manual from the manufacturer.

If you require additional information, or have questions about the Triton Barrier®, please contact Valtir's Customer Service Department. See Customer Service Contacts on Page 3 of this Manual.

CONNECTABLE & INTERLOCKING
STACKABLE
LARGE FILL OPENINGS
SAFETY ACCESSORIES AVAILABLE

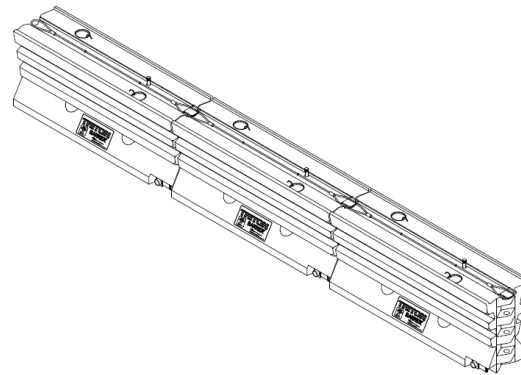
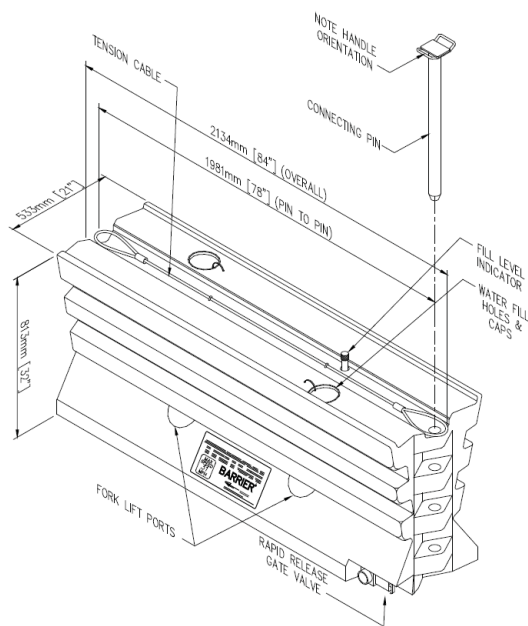

CAPACITY:

550L [145 GAL.]

WEIGHT:

595KG [1312 LBS] FULL

45 KG [99 LBS] EMPTY

COLORS:

NATURAL [WHITE]

WORK ZONE SAFETY ORANGE

SAFETY RED

HIGHWAY SAFETY YELLOW

**TRITON BARRIER® SECTION
 PART NUMBERS**

WHITE	3595010-0000
ORANGE	3595010-0100
RED	3595010-0400
YELLOW	3595010-0300

Figure 1
Triton Barrier® TL-1 components

Figure 2
Triton Barrier® TL-1 assembly (50 km/h [31 mph])

Special Site Considerations

A traffic control plan, in detail appropriate to the complexity of the work project, shall be prepared and understood by all parties before Triton Barrier® is deployed in a work zone. Some special site considerations are:

1. What is the design speed at the site? The Triton Barrier® (TL-1) is capable of handling impacts from vehicles up to 2000 kg [4400 lbs.] at 50 km/h [31 mph] and angles up to 25 degrees.

LENGTH OF DEPLOYMENT	WATER REQUIRED
30m [100 ft.]	8235 liters [2175 gal]
40m [130 ft.]	10,980 liters [2900 gal]
50m [165 ft.]	13,725 liters [3625 gal]
60m [195 ft.]	16,470 liters [4350 gal]
70m [230 ft.]	19,210 liters [5075 gal]
80m [260 ft.]	21,955 liters [5800 gal]
90m [295 ft.]	24,700 liters [6525 gal]
100m [330 ft.]	27,445 liters [7250 gal]
150m [490 ft.]	41,170 liters [10,875 gal]
200m [655 ft.]	54,890 liters [14,500 gal]

2. What is the length of deployment? A minimum length of Triton Barrier® is needed upstream and downstream of area being shielded to ensure proper impact performance. The minimum length will depend on the design speed of the roadway. For 50 km/h [31 mph] the minimum overall length is 30 m [100']. Refer to the Length of Need (LON) section of the Triton Barrier® Design and Applications Manual for more information.
3. Is an end treatment warranted for the exposed or flared end of Triton Barrier®? If so, an appropriate End Treatment must be attached. Refer to the End Treatment section of the Product Description Manual.
4. What is the lateral offset? As a general rule, a roadside barrier should be placed as far from the traveled way as conditions permit. The barrier-to-hazard clearance to shield rigid objects, equipment, embankments, drop-offs, work crews, etc. should not be less than the lateral deflection of the barrier. See Deflection Chart on Page 18 of this Manual.
5. What foundation will the barrier be deployed on and what is its slope? Triton Barrier® may be deployed on various surfaces. Foundations other than clean asphalt may result in more or less lateral deflection for full design capacity impacts. See Deflection Chart on Page 18 of this Manual. The existence of cross slopes greater than 5% or curbs may create an untested effect on the impacting vehicle.
6. How will the barrier be deployed: (1) as a median barrier, (2) in a bidirectional traffic situation, or (3) a road side application? Proper consideration must be given to Triton Barrier® lateral deflection and End Treatment requirements to minimize the potential of secondary impacts.
7. Can the water ballast be drained at the site? If not, provisions must be made to either siphon out the water ballast or use forklift to move full sections to a location where they can be drained.
8. Will the barrier be used in a climate where the water ballast may freeze? The performance of the barrier is not degraded if the water ballast freezes. However, provisions should be made to handle the full weight of the barrier if this occurs. See Other Considerations section of Triton Barrier® Product Description Manual for more information.

Preparation

Begin preparing for the assembly by reviewing the specified barrier location, design, layout, and orientation. Determine the number of sections needed (See Figure 2 on Page 7). (When connected each section is approximately 2m [78"] long).



Caution: The minimum assembly length is 30m [100'] for TL-1 (50 km/h [31 mph]).

Conduct a parts inventory check to make sure all the necessary components are available before proceeding to the site. Visually check the sections for damage to ensure that they will hold water.

Recommended Tools and Equipment:

For a typical assembly the recommended tools and equipment are:

- Triton Barrier® Assembly & Maintenance Manual
- Application and/or traffic control plan (as required)
- Traffic control equipment (as required)
- Triton Barrier® components
- Transport truck
- Water truck w/pump*
- Sledge hammer
- Pry bar
- Generator (power for optional accessories)
- Forklift (optional)

* A pump with 950-1135 liter/min. [250-300 GPM] output and a 75 mm [3"] dia. minimum x 15-30m [50-100'] long hose with a shutoff control has been shown to be efficient. Time to fill one barrier is approximately 30 seconds.

Note: The above list of tools is a general recommendation. Depending on specific site conditions and the complexity of the assembly specified by the appropriate highway authority, additional or fewer tools may be required. Decisions as to what tools are needed to perform the job are entirely within the discretion of the specifying highway authority and the authority's selected contractor performing the assembly of the system at the authority's specified site.

Deployment and Retrieval

1. A flatbed truck with a low bed is ideal for transporting Triton Barrier®. Load the sections onto the transport truck to stack and position them for the greatest shipping density. Secure the load before transport.

Note: Empty sections may be stacked up to three high. Filled sections may not be stacked.

2. Begin deployment at the upstream traffic end of the site and work downstream. Work from the non-traffic side of the deployment whenever possible. Unload the sections taking care not to damage them. Unloading proceeds much faster if one person remains on the truck and two people work on the ground. If site conditions permit, a fourth person can drive the truck so that sections can be unloaded continuously as the deployment is progressing.
3. Align the sections according to the specified configuration and layout in the traffic control plan.



Caution: Refer to deflection graph when determining minimum clearance between barrier and hazard.



Caution: The existence of any cross slopes in excess of 5% (3 deg.) or curbs may create an untested effect on the impacting vehicle.

Triton Barrier® sections are not symmetrical. Pay special attention to the location of the rapid release gate valve and fill level indicator. The rapid release gate valve should usually be oriented on the side opposite traffic. Reflectors or reflective sheeting may be attached as called for in the traffic control plan.

Bring the sections together and insert a Connecting Pin through the Top Cables and into the overlapping End Knuckles at each joint. Push the Pin in until it is flush with the top of the sections. Take care to orient the handle on the Pin so that the Handle is perpendicular to the length of the barrier.



Warning: Sections must be filled with water to ensure proper impact performance.

4. Completely fill each section with water.



Warning: Sections must be filled with water to ensure proper impact performance.

If it is desirable in colder climates that the water not freezes, and in consideration of local restrictions or regulations, add antifreeze as necessary. See Other Considerations section in the Triton Barrier® Product Description Manual for more information.

Since filling the sections typically takes longer than deployment, it is convenient to have a water truck available as soon as deployment begins. The water truck can follow immediately behind the deployment crew to minimize time in the work zone. Filling proceeds more quickly if one worker drives the water truck and another moves the fill hose from section to section.

5. Place caps in fill holes.
6. If an End Treatment is specified for the layout, follow the instructions provided by the manufacturer and attach it at this time.



Caution: An appropriate End Treatment must be supplied where warranted to achieve impact performance.

7. Deployment is now complete. Take the time to double check the assembly as shown below.

Checking the Assembly

Check the assembly to ensure that all sections are properly aligned, full of water ballast, and not leaking. All fill level indicators should be up. If any are not up, check to see if the decals used for shipment are still in place and remove them. Make sure that all cables are present and all Pins are inserted. If for some reason a section needs replacement, refer to the Maintenance and Repair section of this Manual on Page 13.

Retrieval

1. Begin retrieval at the downstream traffic end of the site and proceed upstream. Begin the retrieval procedure by removing the water ballast. If site conditions permit, the quick release gate valve may be opened to allow the water to drain. Insert the protective fill level indicator caps.

Note: The time it takes to drain a barrier section is approximately 4 1/2 minutes.



Caution: Water on the traveled roadway may create a slippery surface for vehicles. Proper traffic control should be deployed.

If the water may not be drained at the site, then the water may either be siphoned out or the section can be unpinned and moved by forklift to another work area or site where it may be drained or stored.



Caution: Do not use tension cables to lift barrier.

2. Once the water is removed, the pins may be removed and the sections separated.
3. Remove the empty sections onto the transport truck in the reverse order as they were deployed. Secure the load before transport.

Storing

When storing the Triton Barrier[®], be sure to leave the gate valve open or store upside down.

Note: Empty sections may be stacked up to three high. Filled sections may not be stacked.

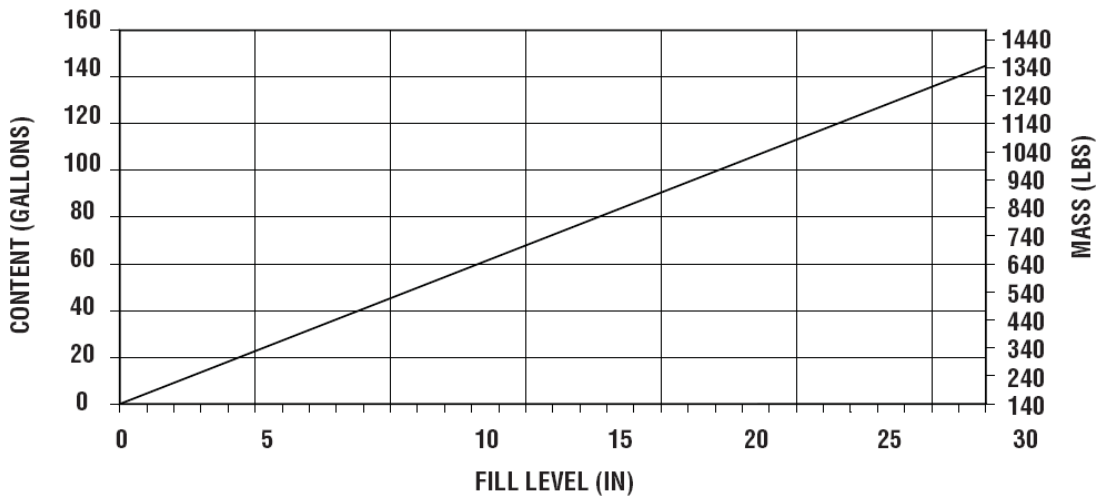
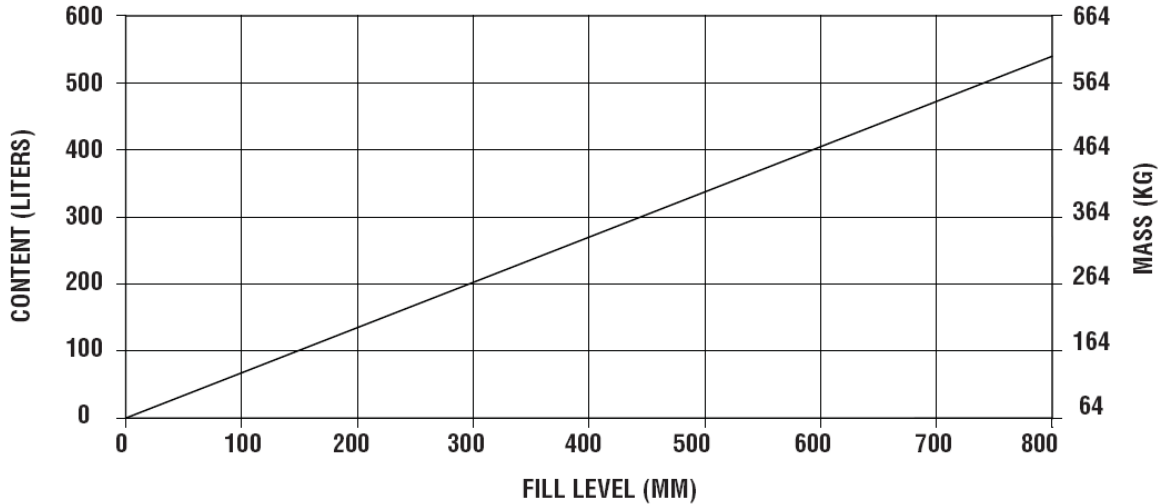

Figure 3
Triton Barrier[®] fill capacity chart

Note: Chart is shown for purpose of moving partially filled barrier sections. Barriers must be full when in use.

Maintenance and Repair

To Remove Pin

1. Pry Pin up while pushing cable loops down.
2. Once Pin is up approximately 100 to 125 mm [4" to 5"], the Pin can be twisted to remove.

Proper maintenance of Triton Barrier® is essential to achieve performance of the system under appropriate federal and state guidelines. Take the time to review the product limitations, assembly cautions, and maintenance instructions before performing the necessary work. Do not attempt to deploy any longitudinal barrier without the proper plans for the deployment.

The time interval between maintenance inspections depends a great deal upon particular site conditions. Frequent inspections are recommended until a longer inspection interval becomes justified.

Visual Drive-By Inspection

A slow drive-by visual inspection of Triton Barrier® is often all that is required. Some special inspection considerations are:

1. Are the sections full of water ballast? The sections must be adequately filled for proper impact performance. Look to see that the fill level indicators are visible above the top of each section. A walk-up inspection of the assembly is required if the fill indicators are not visible (See Walk-Up Inspection section). Be sure fill indicator caps used for shipping have been removed.
2. Are the sections properly aligned? The deployment must be aligned according to the plans for the site. Misaligned sections in the middle of an assembly may be an indication that the barrier has been hit and potentially damaged. If any sections are misaligned, carry out a walk-up inspection.

Walk-up Inspection

If the drive-by visual inspection indicates maintenance is required, then a walk-up inspection is necessary. Some of the most common maintenance concerns and corresponding repair techniques are:

Empty Sections

Sections with water levels below 100 mm [4"] from the top must be refilled for proper Triton Barrier® performance. Sections with very low water levels, or those that consistently need filling, should be filled and thoroughly inspected for leaks. If leaks are found, the section should be replaced (See Damaged Sections). A certain amount of water loss may occur due to evaporation depending on the environment.

Damaged Sections

Generally sections are usable if they remain full of water and properly connected to other sections. Occasionally, sections may become damaged from impact or puncture and must be replaced. Sections with minor damage or leaks may often be repaired using sealants or plastic welding methods. (See Triton Barrier® Patching.) Empty the water from the sections immediately surrounding the damaged section(s). Remove the Pins holding the damaged section(s) and slide the section(s) sideways until enough gap opens up in the assembly for removal. New sections are replaced by reversing this process. Take care to work in a direction away from traffic and to properly line up the deployment when replacement is complete (See Misaligned Sections on Page 14).

Misaligned Sections

Sections may occasionally become misaligned due to impact or nuisance hits. Generally 600-900 mm [2 to 3'] of lateral misalignment is easily corrected by simply pushing the sections back into alignment. If the sections are emptied, they can usually be pushed manually; if they are full, they can be nudged into position with a vehicle, pry bar, or forklift, being sure to use the forklift ports. Care must be taken to avoid damaging the sections.

Triton Barrier® Patching Preparation

The area to be patched must be completely dry and free of dirt and grease. Additionally, a film coats the barrier and should be removed by either lightly sanding the pieces or burning it off with a small butane torch. Do not damage the plastic by overheating. A few quick passes are sufficient.

Options:

Plastic Welding

The most reliable means of patching can be accomplished with plastic welding and can range from "stick" welding to automatic preparation and feed. The temperature, as measured 6 mm [1/4"] away from the welding torch, should be at 290 deg. C [550 deg. F.] for the Triton Barrier® material. Welding speed for ideal, straight line welds can range from 100 mm - 150 mm [4" to 6"] per minute with stick welding to 600 mm [24"] per minute with an automatic gun. A plastic welding equipment supplier can offer additional information.

Spin Weld Plugs

Spin Weld plugs give excellent results for patching small holes and leaks in Triton Barriers®. Individuals who will be performing the repairs should read the instructions and practice a few times before trying to repair Triton Barrier®. Practicing the Spin Weld process is important as this gives the individual a feel for the techniques required to perform a proper weld.

Items necessary for repair:

- Drill Motor w/7 mm drill bit
 - 25,000 rpm Router
 - Spin Weld tool
 - Spin Weld plugs
 - Rasp
1. Drill 7 mm hole at point of leak.
 2. Secure the Spin Weld tool onto Router.
 3. Place a Spin Weld plug onto the Spin Weld tool.
 4. Place plug and router squarely over the hole to be plugged.
 5. Turn on router, holding it firmly with light downward pressure. Watch for indications of melting plastic flowing around the plug. Turn off the router, holding it steady until the plastic solidifies.
 6. Inspect plug to insure that it has bonded to the Barrier.
 7. Rasp plugged area smooth to finish repair.

Hot Glue Gun

Relatively good success in patching the Triton Barrier® can be accomplished with a standard hot glue gun using general purpose adhesive. This type of patching will deteriorate over an extended period of exposure to the sun, etc. The best results will be obtained by using patience and large amounts of glue.

Field Patching

Initial preparation as outlined above should be accomplished whenever feasible. No materials are available that adhere properly when applied to a wet Barrier. Duct tape (silver, fiber reinforced tape) sticks to the barrier well, and Butyl caulking (gray, sticky pads or rolls) works fairly well to fill gaps for temporary patching.

The black and white Triton Barrier® decals stick well to the barriers. Spare decals can be kept on hand and cut to size with scissors for effective temporary patch. The decal will need to be placed smoothly without air pockets or creases to obtain the best results. Smaller holes on smooth faces will seal while larger gashes can be reduced to minor trickles. Should the decal begin to leak, it will deteriorate rapidly.

Either fiberglass resin or epoxy can be used to fill and plug leaks. Epoxy's liquid consistency makes it more difficult to keep in any hole during its cure, but is effective if this shortfall can be overcome. Fiberglass resin and sheeting/cloth can be used on larger areas. The exterior of the matte must be completely covered with resin. Otherwise, any exposed fibers will quickly act like wicks and the patch will fail. The resin or epoxy will require a curing time before the Barrier may be refilled with water.

Any repaired Barriers should be marked for easy identification. It is recommended to periodically check the repairs for leaks.

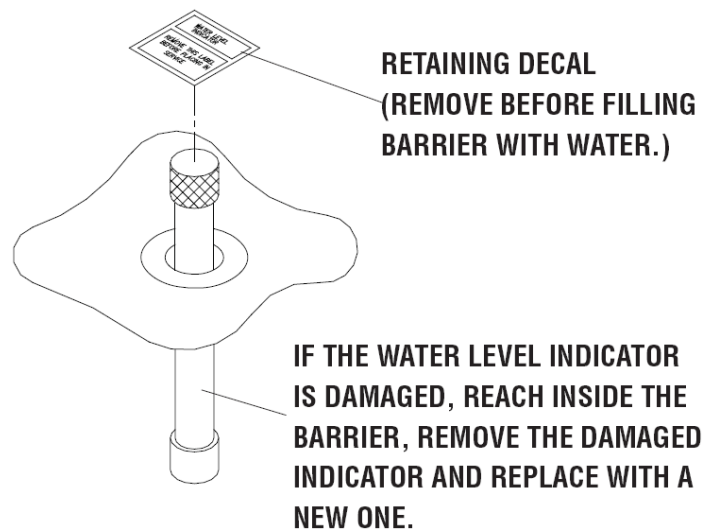

Figure 4
Water level indicator

Gate Valves and Plugs

Gate valves must be unbolted before they can be unscrewed. Six or seven wraps of Teflon® tape will keep the threads from leaking.

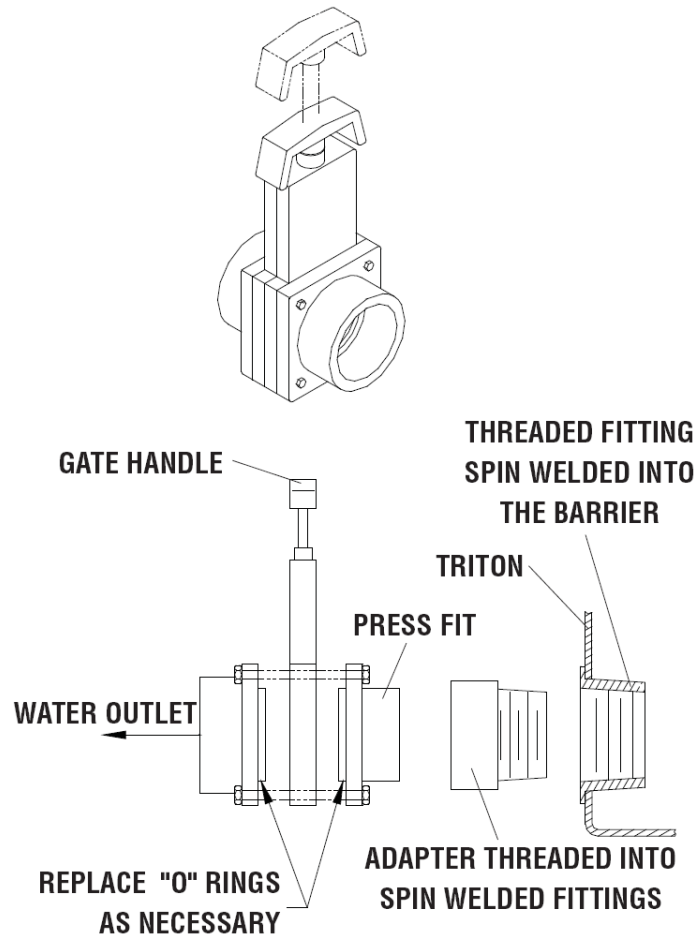

Figure 5
Repair of the gate valve

Deflection/Clear Zone

To determine the expected deflection, refer to Figure 6 and determine the value for S (in feet) for the site in question. S is the perpendicular distance from the face of the Barrier out to the nearest side of a reference vehicle (a 3/4 ton pickup truck) which is driving exactly in the center of the lane furthest from the barrier.

Clear zone is defined by AASHTO Roadside Design Guide, 1989 and NCHRP 340 as:

“The total roadside border area, starting at the edge of the traveled way, available for safe use by errant vehicles. This area may consist of a shoulder, a recoverable slope, a non-recoverable slope, and/or a clear run-out area. The desired width is dependent upon the traffic volumes and speeds, and on the roadside geometry.” The clear zone must allow for the deflection of the Triton Barrier®.

Except for an anchored rigid barrier, all Barriers will experience some amount of deflection.

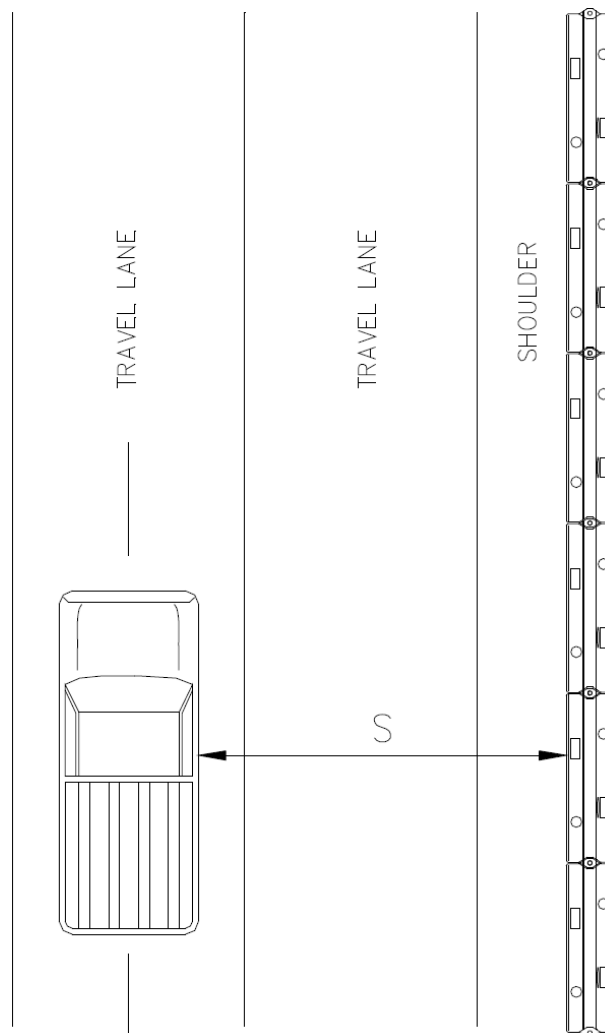

Figure 6
Using S, refer to the Triton Barrier® Expected Deflection Range Chart (Figure 7) to determine the Expected Deflection (in feet).

Triton Barrier[®] Expected Deflection Ranges

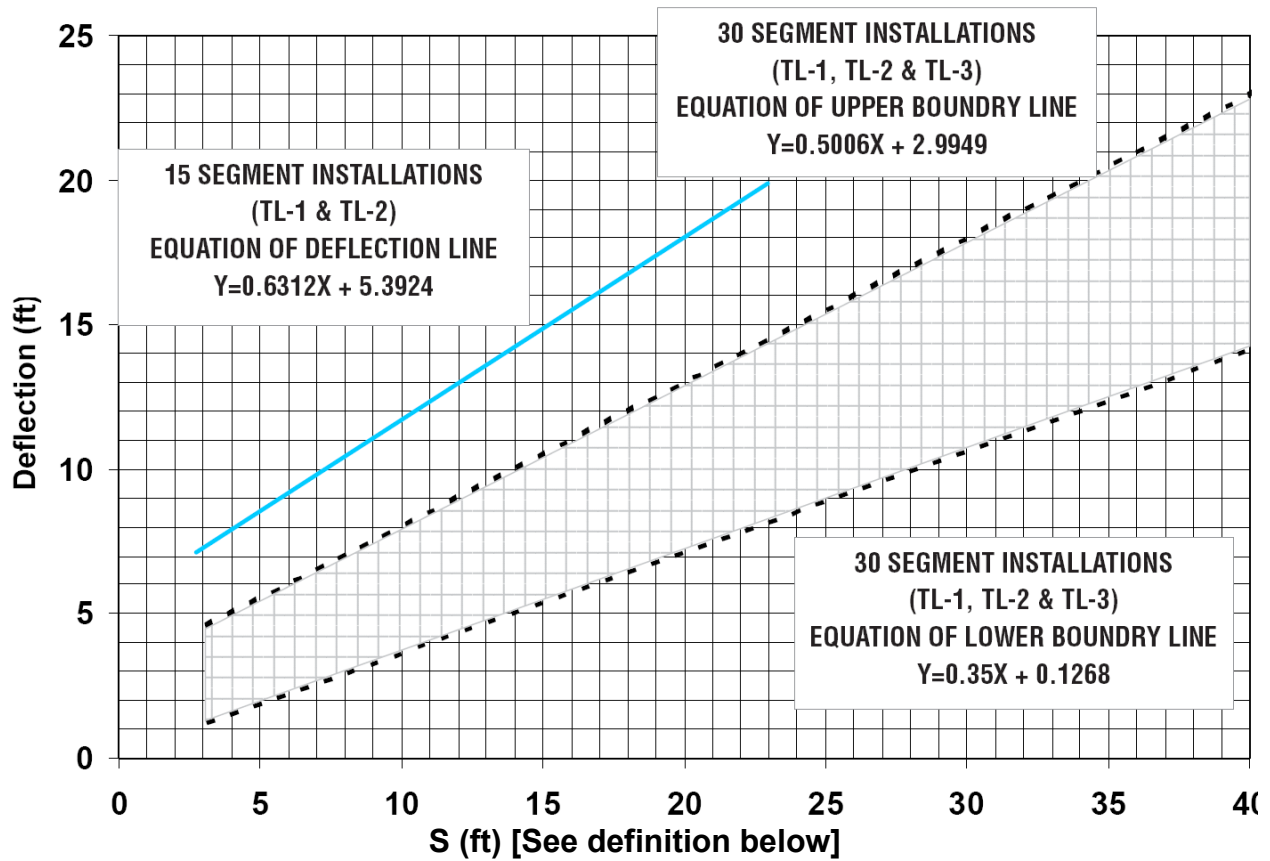

Figure 7

Definition:

S is the perpendicular distance from the face of the barrier out to the nearest side of a reference vehicle (a 3/4 ton pickup truck) that is driving exactly in the center of the lane farthest from the barrier (See Figure 6).



For more complete information on Valtir products and services, visit us on the web at www.valtir.com. Materials and specifications are subject to change without notice. Please contact Valtir to confirm that you are referring to the most current instructions.

WWW.VALTIR.COM
1.888.323.6374