



QuadGuard[®] Elite

CRASH CUSHION

ASSEMBLY MANUAL



PN 115269
REVISION | NOVEMBER 2022

QuadGuard® Elite

The QuadGuard® Elite has been tested pursuant to National Cooperative Highway Research Program (“NCHRP”) Report 350 specifications. The QuadGuard® Elite has been deemed eligible for federal-aid reimbursement on the National Highway System by the Federal Highway Administration (“FHWA”).

Assembly Manual



15601 Dallas Parkway
Suite 525
Addison, Texas 75001



Warning: The local highway authority, distributors, owners, contractors, lessors, and lessees are responsible for the assembly, maintenance, and repair of the QuadGuard® Elite. Failure to fulfill these **RESPONSIBILITIES** with respect to the assembly, maintenance, and repair of the QuadGuard® Elite could result in serious injury or death.



Important: These instructions are for standard assembly specified by the appropriate highway authority. In the event the specified system assembly, maintenance, or repair would result in a deviation from these assembly instructions, contact the appropriate highway authority engineer.

This manual must be available to the worker overseeing and/or assembling the product at all times. For additional copies, contact Valtir at (888) 323-6374 or visit Valtir.com/Products/.

The information contained in this manual supersedes all previous versions. The instructions, illustrations, and specifications are based on the latest QuadGuard® Elite information available to Valtir at publication. We reserve the right to make changes at any time. Please visit Valtir.com/Product/QuadGuard Elite/ to confirm the latest revision.

Table of Contents

Customer Service Contacts	3
Important Introductory Notes	3
Safety Symbols	4
Safety Rules for Assembly	4
Limitations and Warnings	5
System Overview	6
QuadGuard® Elite Foundation/Anchoring	7
Valtir Approved Adhesive Anchoring System	8
Anchor Assemblies	8
Assembly Cautions	9
Recommended Tools	10
QuadGuard® Elite for Narrow Roadside Obstacles.....	14
Assembly.....	14
QuadGuard® Elite for Wide Roadside Obstacles	33
Assembly.....	34
Maintenance	52
Visual Drive-By Inspection	52
Walk-Up Inspection	52
Post-Impact.....	54
Restore Collapsed System.....	57
Parts Ordering Procedure	58
Maintenance Flow Chart.....	61
Final Inspection Checklist	62
Inspection Logbook.....	63

Customer Service Contacts

Valtir is committed to the highest level of customer service. Feedback regarding the QuadGuard® Elite, its assembly procedures, supporting documentation, and performance is always welcome. Please contact Valtir for additional information:

Valtir

Telephone	(888) 323-6374 (USA) +1 312 467-6750 (International)
Contact Link	Valtir.com/Contact

Important Introductory Notes

Proper assembly of the QuadGuard® Elite is critical to achieve performance that has been evaluated and deemed eligible for reimbursement by the FHWA per NCHRP Report 350. These instructions should be read in their entirety and understood before assembling the QuadGuard® Elite. These instructions are to be used in conjunction with the assembly of QuadGuard® Elite systems and are for standard assemblies only as specified by the applicable highway authority. If you need additional information, or have questions about the QuadGuard® Elite, please contact the highway authority that has planned and specified this assembly and, if needed, contact Valtir Customer Service. This product must be assembled in the location specified by the appropriate highway authority. If there are deviations, alterations, or departures from the assembly protocol specified in this manual, the device may not perform as tested.



Important: DO NOT use any component part that has not been specifically approved for this system during the assembly or repair of this system.

This product has been specified for use by the appropriate highway authority and has been provided to that user who has unique knowledge of how this system is to be assembled. No person should be permitted to assemble, maintain, or repair this system that does not possess the unique knowledge described herein. These instructions are intended for an individual qualified to both read and accurately interpret them as written. These instructions are intended only for an individual experienced and skilled in the assembly of highway products that are specified and selected by the highway authority.

Each system will be supplied with a specific drawing package unique to that system. Such drawings take precedence over information in this manual and shall be studied thoroughly by a qualified individual who is skilled in interpreting them before the start of any product assembly.

Safety Symbols

This section describes the safety symbols that appear in this QuadGuard® Elite manual. Read the manual for complete safety and assembly information.

Symbol

Meaning



Safety Alert Symbol: Indicates Danger, Warning, Caution, or Important. Failure to read and follow the Danger, Warning, Caution, or Important indicators could result in serious injury or death to the workers and/or bystanders.



Important: Read safety instructions thoroughly and follow the assembly directions and suggested safe practices before assembling, maintaining, or repairing the QuadGuard® Elite. Failure to comply with these warnings could result in increased risk of serious injury or death in the event of a vehicle impact with a system that has not been deemed eligible by the FHWA



Important: Please keep up-to-date instructions for later use and reference by anyone involved in the assembly of the product.

Safety Rules for Assembly

*** Important Safety Instructions ***

This manual must be kept in a location where it is readily available to persons who are skilled and experienced in the assembly, maintenance, or repair of the QuadGuard® Elite. Additional copies of this manual are available from Valtir by calling (888) 323-6374 or visiting Valtir.com/Product/QuadGuard_Elite/. Please contact Valtir if you have any questions concerning the information in this manual or about the QuadGuard® Elite.

Always use appropriate safety precautions when operating power equipment, mixing chemicals, and when moving heavy equipment or the QuadGuard® Elite components. Work gloves, eye protection, safety-toe shoes, and back protection should be used.

Safety measures incorporating traffic control devices specified by the highway authority must be used to provide safety for personnel while at the assembly, maintenance, or repair site.



Warning: It is the responsibility of the installer to use all safety measures incorporating appropriate traffic control devices specified by the highway authority must be used to protect all personnel while at the assembly, maintenance, or repair site.



Warning: It is the responsibility of the installer to ensure that your assembly procedure meets all appropriate Occupational Safety and Health Administration (OSHA) and local standards.

Limitations and Warnings

Valtir contracts with FHWA approved testing facilities to perform, evaluate, and submit crash test results to the FHWA for review.

The QuadGuard® Elite has been deemed eligible by FHWA as meeting the requirements and guidelines of NCHRP Report 350. These tests typically evaluate product performance defined by NCHRP Report 350 involving a range of vehicles on roadways, from lightweight cars (approx. 1800 lb. [820 kg]) to full size pickup trucks (approx. 4400 lb. [2000 kg]). A product can be certified for multiple Test Levels. The QuadGuard® Elite is certified to the Test Level(s) as shown below:

Test Level 2: 43 mph [70 kph]

Test Level 3: 62 mph [100 kph]

FHWA directed tests are not intended to represent the performance of systems when impacted by every vehicle type or roadway impact condition. This system is tested only to the test matrix criteria of NCHRP Report 350 as approved by FHWA.

Valtir expressly disclaims any warranty or liability for injury or damage to persons or property resulting from any impact, collision or harmful contact with products, other vehicles, or nearby hazards or objects by any vehicle, object or person, whether or not the products were assembled in consultation with Valtir or by third parties.

The QuadGuard® Elite is intended to be assembled, delineated, and maintained within specific state and federal guidelines. It is important for the highway authority specifying the use of a highway product to select the most appropriate product configuration for its site specifications. The customer should be careful to properly select, assemble, and maintain the product. Site lay out, vehicle population type; speed, traffic direction, and visibility are important elements that require evaluation in the selection of a highway product. For example, curbs could cause an untested effect on an impacting vehicle.

After an impact occurs, the debris from the impact should be removed from the area immediately and the specified highway product should be evaluated and restored to its original specified condition or replaced as the highway authority determines as soon as possible.



Warning: Do not assemble, maintain, or repair the QuadGuard® Elite until you have read this manual thoroughly and completely understand it. Ensure that all Danger, Warning, Caution, and Important statements within the manual are completely followed. Please contact Valtir if you do not understand these instructions (p. 3).

System Overview

The QuadGuard® Elite is a potentially reusable, re-directive, non-gating crash cushion for roadside features ranging in width from 24” to 90” [610 mm to 2285 mm]. It consists of energy-absorbing Cylinders surrounded by a framework of quad-beam panels. The decision as to whether this product is reusable after impact rests within the sound discretion of the trained engineer, experienced in highway products, who is working at the direction of the local DOT, or appropriate highway authority, which specified and now owns the product.

The QuadGuard® Elite utilizes two (2) types of cylinders in a “staged” configuration to address both lighter cars and heavier, high center-of-gravity vehicles. Its modular design allows the system length to be tailored to the design speed of a site.

Impact Performance

The 5 Bay and 7 Bay EC QuadGuard® Elite systems have successfully passed the requirements stipulated in NCHRP Report 350, Test Level Two (43 mph [70 kph]).

The 8 Bay and 11 Bay EC QuadGuard® Elite systems have successfully passed the requirements stipulated in NCHRP Report 350, Test Level Three (62 mph [100 kph]).

The “EC” designation stands for “Extra Capacity”. This system has additional energy absorbing capacity.

The 14 Bay 24”, 30” and 36” wide QuadGuard® Elite have successfully been tested with a pickup truck at speeds up to 70 mph [115 kph].

During head-on impact testing, within NCHRP Report 350 criteria, the QuadGuard® Elite has been shown to telescope rearward to absorb the energy of impact. When impacted from the side, within the applicable NCHRP Report 350 criteria, it has been shown to redirect the vehicle back toward its original travel path and away from the highway feature.



Important: Systems mounted on asphalt must be replaced and mounted on fresh, undisturbed asphalt if more than 10% of anchors are found to be loose, broken, or show signs of pull out. If 10% or fewer anchors are damaged, replace the damaged anchors in the existing asphalt. Anchor bolts used on systems mounted on asphalt must be inspected every six months. Please review Maintenance and Post-Impact instructions for more information (pp. 54-59).

QuadGuard® Elite Foundation/Anchoring



Warning: Ensure the proposed assembly site conforms with the guidance provided by the AASHTO Roadside Design Guide, including, but not limited to, guidance regarding placement on or adjacent to curbs.

Asphalt Installations

QuadGuard® Elite Narrow systems with a Tension-Strut Backup may be installed in construction zones on asphalt. Assemblies on **Asphalt Concrete (“A.C.”)** must provide a minimum of 3” [76 mm] layer of asphalt over a minimum of 3” [76 mm] layer of **Portland Cement Concrete (“P.C.C.”)**, 6” [152 mm] layer of asphalt over 6” [152 mm] layer of subbase, or 8” [203 mm] layer of asphalt with no subbase



Important: Only 18” [460 mm] threaded rods, utilizing Valtir approved adhesive, can be used with asphalt foundations. Contact Customer Service for a complete list of approved adhesives (p. 3).



Important: QuadGuard® Elite **Wide** systems should not be anchored to asphalt.

Concrete Installations

The QuadGuard® Elite can only be installed on an existing or freshly placed and cured concrete base (4000 psi [28 MPa] minimum concrete strength). Orientation of the concrete base and the attenuator must comply with the project plans or as otherwise determined by the project engineer or appropriate highway authority.

Recommended dimension and reinforcement specifications for new concrete pads can be found on the standard drawings.

The QuadGuard® Elite may be installed on any of the following foundations using the specified anchorage:

Foundation A: Concrete Pad or Roadway

Foundation: 6” [150 mm] minimum depth P.C.C.

Anchorage: Approved adhesive with 7” [180 mm] studs 5 1/2” [140 mm] embedment

Foundation B: Asphalt over P.C.C.

Foundation: 3” [76 mm] minimum A.C. over 3” [76 mm] minimum P.C.C.

Anchorage: Length of anchor required is 18” [460 mm] 16 1/2” [420 mm] embedment

Foundation C: Asphalt over Compacted Subbase (“C.S.”)

Foundation: 6” [150 mm] minimum A.C. over 6” [150 mm] minimum C.S.

Anchorage: Approved adhesive with 18” [460 mm] studs 16 1/2” [420 mm] embedment

Foundation D: Asphalt

Foundation: 8” [200 mm] minimum A.C.

Anchorage: Approved adhesive with 18” [460 mm] studs - 16 1/2” [420 mm] embedment

Valtir Approved Adhesive Anchoring System

A Valtir approved adhesive anchoring system is required to securely anchor crash cushions. Each approved adhesive kit contains adhesive, studs, nuts, washers and instructions. Both vertical and horizontal assemblies are possible using an approved adhesive anchoring system.



Important: Follow adhesive manufacturer’s temperature storage requirements.

Anchor Assemblies

Note: Read all Valtir approved adhesive instructions before starting.

1) Prepare the Concrete Foundation



Warning: Do not allow anchoring adhesive to contact skin or eyes. See material safety data sheet supplied with adhesive kit for first-aid procedures. Use only in well-ventilated area. Do not use near open flame.

The anchor bolts (studs) that anchor the QuadGuard® Elite Backup and/or Monorail sections to the concrete foundation must be those shipped in the kit or of high strength steel (120,000 psi [830 MPa] minimum tensile strength or equal). These studs must be set in minimum 4000 psi [28 MPa] concrete. Allow the concrete to cure a minimum of seven days before applying anchoring adhesive.

2) Drill Boreholes



Caution: It is the responsibility of the installer to consult OSHA silica respiratory standard 29 CFR 1910.134 for debris removal from borehole(s) and use Valtir approved adhesive to achieve optimum tensile strength. Do not use diamond drill bits for drilling boreholes.

Use the part that is to be anchored as a drilling template. Use a rotary hammer drill to drill the boreholes 1/8” [3 mm] larger than the stud diameter to the recommended depth. See the approved adhesive instructions provided with your kit. Check to be sure all the boreholes are drilled to the proper depth and aligned with the part to be anchored per chart below.

Anchor Drilling Information					
Anchor Size:	Orientation	Bit Size	Minimum Depth	Torque	Medium
3/4”x 6 1/2”	Horizontal	7/8” [22 mm]	5 1/4” [125 mm]	Manufacturer Spec	Concrete
3/4”x 7”	Vertical	7/8” [22 mm]	5 3/4” [140 mm]	Manufacturer Spec	Concrete
3/4”x 18”	Vertical	7/8” [22 mm]	16 1/2” [420 mm]	10 ft-lbf [15 N-m] ⚠	Asphalt



Important: When mounting on asphalt, initial torque shall be as shown above. Due to the properties of asphalt, anchors may loosen over time. For this reason Valtir recommends anchoring to asphalt only at temporary locations. It is recommended to re-torque anchors in asphalt every six months to the proper initial torque specified.

3) Clean the Boreholes

Blow the concrete dust from the borehole using 90 psi oil-free compressed air. Thoroughly brush the borehole with a 7/8" diameter steel bristle tube brush and then blow it out again to ensure it is completely dry and debris free.

4) Apply Approved Adhesive

Fill the borehole with enough adhesive so when the anchor is inserted a small portion of anchoring adhesive is squeezed out.



Caution: Fill the borehole from bottom up to prevent air pockets. Do not overfill or under-fill the borehole. If the borehole is overfilled, there will not be enough adhesive to anchor all of the studs provided in the kit. If borehole is under-filled, the adhesive may not develop the required pull out strength.

5) Add Nuts to Anchor Studs

Thread the nut on until flush with the end of the stud (Figure 1).

6) Insert Studs in Boreholes and Wait for Adhesive to Cure

Push the stud, nut, and washer assembly down through the part and into the borehole until the washer is seated against the part (Figure 1).



Warning: Do not disturb or load the stud until the approved adhesive material has fully cured per manufacturer instructions.

7) Torque the Nuts

Once the adhesive has fully cured, torque the nut to the manufacturer's recommended values.

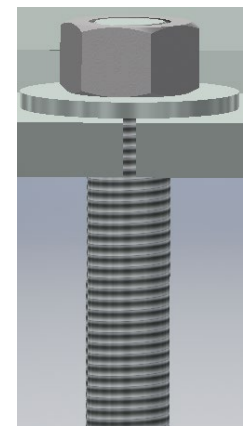

Figure 1
Anchor Application
(Before Applied Torque)

Assembly Cautions

1) Steel rebar

If steel rebar is encountered while drilling an anchor bolt borehole, apply one of the following solutions:

- A) Using a diamond core drill bit or rebar drilling tool, drill through the rebar only, then switch back to the concrete bit and drill into the underlying concrete until the proper borehole depth is reached.



Caution: Do not drill through rebar without first obtaining permission to do so from the project engineer.

- B) Drill a new borehole down at an angle past the rebar to the proper depth. Anchor the stud by completely filling both boreholes with an approved adhesive.

Recommended Tools

Documentation

- Manufacturer's Assembly Manual
- Manufacturer's Drawing Package

Personal Protective equipment

- Eye Protection
- Gloves
- Safety-toe shoes

Cutting equipment

- Rotary Hammer Drill
- Rebar cutting bit
- Concrete drill bits – 7/8" [22 mm] (**Double-Fluted**)
- Grinder, Hacksaw or Torch (optional)
- Drill bits 1/16" through 7/8"



Important: Valtir recommends using double-fluted drill bits to achieve optimum tensile strength when applying an approved adhesive to the anchoring system (p. 10).

Hammers

- Sledgehammer
- Standard hammer

Wrenches

- Heavy duty impact wrench: 1/2"
- Crescent Wrench: 12" [300 mm]
- 1/2" drive Sockets: 9/16", 11/16", 3/4", 15/16", 1 1/8", 1 1/4"
- 1/2" drive Deep Sockets: 15/16", 1 1/4"
- 1/2" drive Ratchet and attachments
- 1/2" drive Breaker Bar - 24" long
- 1/2" drive Torque Wrench: 200 ft.-lbf.
- Allen Wrench: 3/8"



Important: Because every impact is different, Valtir makes no recommendation whether use or reuse of any part of the system is appropriate or acceptable following an impact. It is the sole responsibility of the project engineer and/or the local highway authority and its engineers to make that determination. It is critical that you inspect this product after assembly is complete to make certain that the instructions provided in this manual have been strictly followed.

Miscellaneous

- Traffic control equipment
- Lifting and moving equipment (A lifting device is preferred although a forklift can be used.) Minimum 5,000 lb. capacity required.
- Air Compressor (oil-free & 90 psi minimum) and Generator (5 kW)
- Long pry bar
- Drift pin 12" [300 mm]
- Center punch
- Tape measure 25' [7.5 m]
- Chalk line
- Concrete marking pencil
- Steel bristle tube brush 7/8" for cleaning 7/8" drilled boreholes
- Rags, water, and solvent for touch-up
- Chain, 3/8" grade 40, 20' [6 m] with 1/2" [13 mm] hooks.

Note: The above list of tools is a general recommendation and should not be considered an extensive list. Depending on specific site conditions and the complexity of the assembly specified by the appropriate highway authority the required tools may vary. Decisions as to what tools are needed to perform the job are entirely within the discretion of the specifying highway authority and the authority's selected contractor performing the assembly of the system at the authority's specified assembly site.

QuadGuard® Elite Parallel Widths

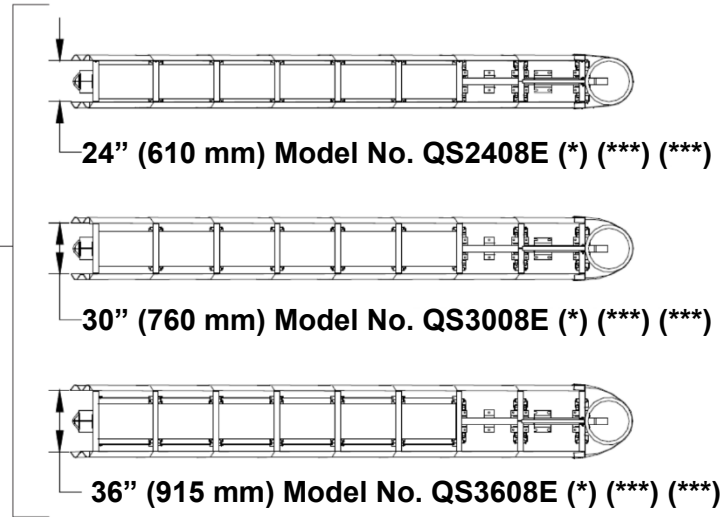

QuadGuard® Elite Flared Widths

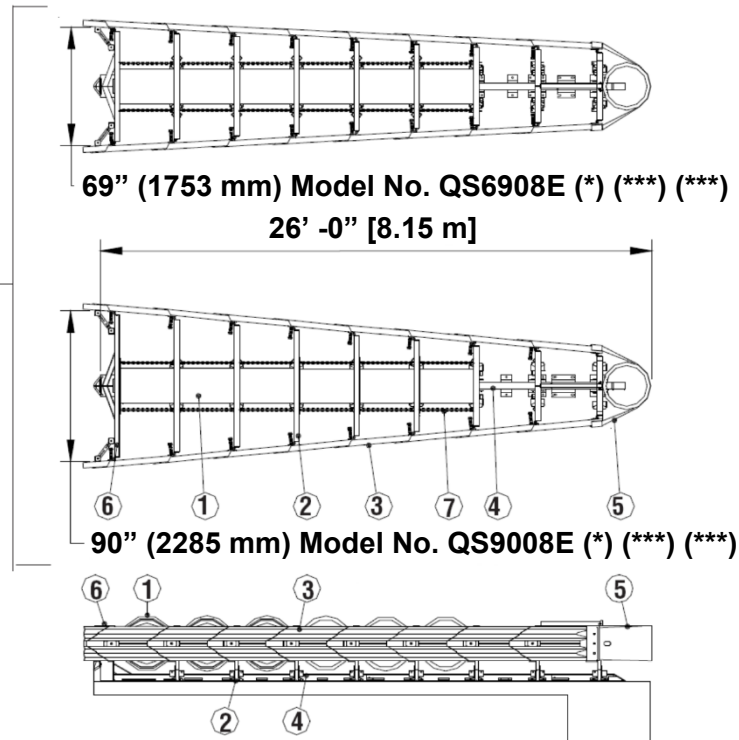

Key

- 1) Energy-Absorbing Cylinder
- 2) Diaphragm
- 3) Quad-Beam Fender Panel
- 4) Monorail
- 5) Nose Cover
- 6) Backup
- 7) Chain Assembly

Elevation

- * Also Available in 5 Bay Lengths
- ** Also Available in 7 Bay Lengths (EC Model)
- *** Also Available in 11 Bay Lengths (EC Model)
- **** Also Available in 14 Bay Lengths

Figure 2
Plan & Elevation

How to Determine Left/Right

To determine left from right when ordering parts, stand in front of the system facing the roadside feature. Your left is the system's left and your right is the system's right.

Counting the Number of Bays

One Bay consists of (1) Diaphragm, (2) Fender Panels, etc. The Nose Assembly is not considered a Bay (Figure 4).

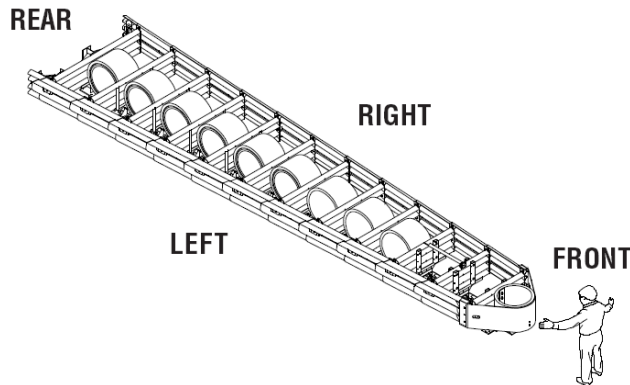

Figure 3
Left/Right

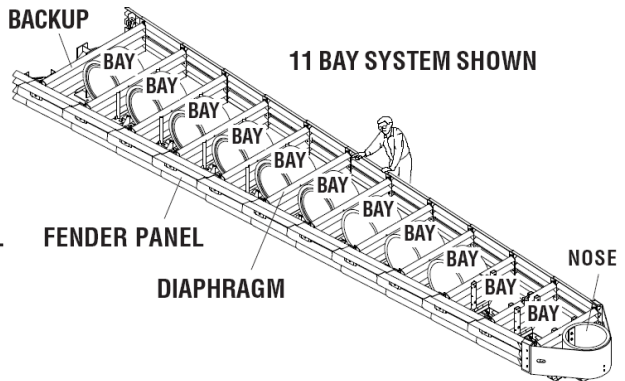

Figure 4
Number of Bays

System Width	5 Bay 43 mph [70 kph]	7 Bay EC 53 mph [85 kph]	8 Bay 62 mph [100 kph]	11 Bay EC 65 mph [105 kph]	14 Bay 72 mph [115 kph]
610mm [24"]	QS2405E	QS2407E	QS2408E	QS2411E	QS2414E
760mm [30"]	QS3005E	QS3007E	QS3008E	QS3011E	QS3014E
915mm [36"]	QS3605E	QS3607E	QS3608E	QS3611E	QS3614E
1755mm [69"]	QS6905E	QS6907E	QS6908E	QS6911E	Not Available
2285mm [90"]	QS9005E	QS9007E	QS9008E	QS9011E	Not Available

The nominal width of the Tension Strut Backup is the width between Side Panels behind the Backup (Figure 5). The outside width of the system is approximately 6" [150 mm] to 9" [230 mm] wider than this measurement.

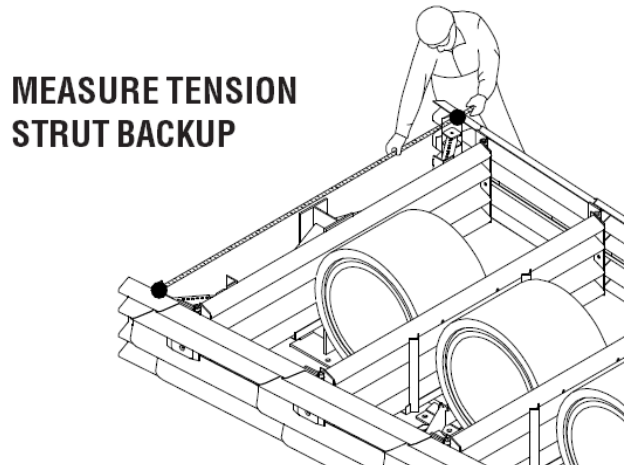
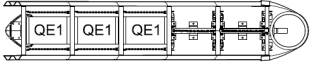
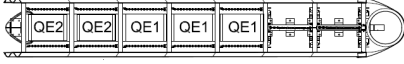
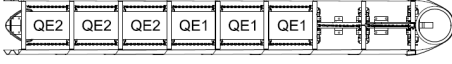



Figure 5
Tension Strut Backup Width

QuadGuard® Elite for Narrow Roadside Obstacles

<p>5 BAYS</p> 	<p>QS2405E QS3005E QS3605E</p>
<p>7 BAYS</p> 	<p>QS2407E QS3007E QS3607E</p>
<p>8 BAYS</p> 	<p>QS2408E QS3008E QS3608E</p>
<p>11 BAYS</p> 	<p>QS2411E QS3011E QS3611E</p>
<p>14 BAYS</p> 	<p>QS2414E QS3014E QS3614E</p>

Assembly

Inspect Shipping

Before deploying the QuadGuard® Elite, check the received parts against the shipping list supplied with the system. Make sure all parts have been received.

Recommended dimension and reinforcement specifications for new concrete foundations are provided in the Valtir Concrete Foundation drawing that is supplied with the system. The system may be assembled on a non-reinforced concrete roadway (minimum 8" [200 mm] thick). Foundation cross-slope shall not exceed 8% and no more than 2% over the length of the system; the foundation surface shall have a light broom finish.



Caution: Accurate placement of all steel rebar is critical to avoid interference with the concrete anchor bolts.



Warning: Location of the Backup in relation to nearby objects will affect the operation of the attenuator. Upon impact, the Fender Panels telescope rearward and extend beyond the rigid Backup as much as 25" [635 mm] from their pre-impact location. Position the Backup so that the rear ends of the last Fender Panels are a minimum of 25" [635 mm] forward of objects that would otherwise interfere with movement of the panels. Failure to comply with this requirement is likely to result in system performance which had not been crash tested pursuant to NCHRP Report 350 criteria and may also cause component damage which will necessitate maintenance or replacement of the system.

Assembly Steps

Note: The Drawing Package supplied with the QuadGuard® Elite must be used with these instructions for proper assembly and should take precedence over these general instructions.

1) Determine Backup & Transition Type

The QuadGuard® Elite uses a **Tension Strut Backup (A)** or **Concrete Backup (B)**.

A Transition Panel or Side Panel must be used for the system to perform as crash tested on each side of the Backup. A Side Panel is not needed when a Transition Panel is used. Several types of transitions are available for use with the QuadGuard® Elite. See Figures 7 through 11 and the Drawing Package to determine which type of panel to attach.

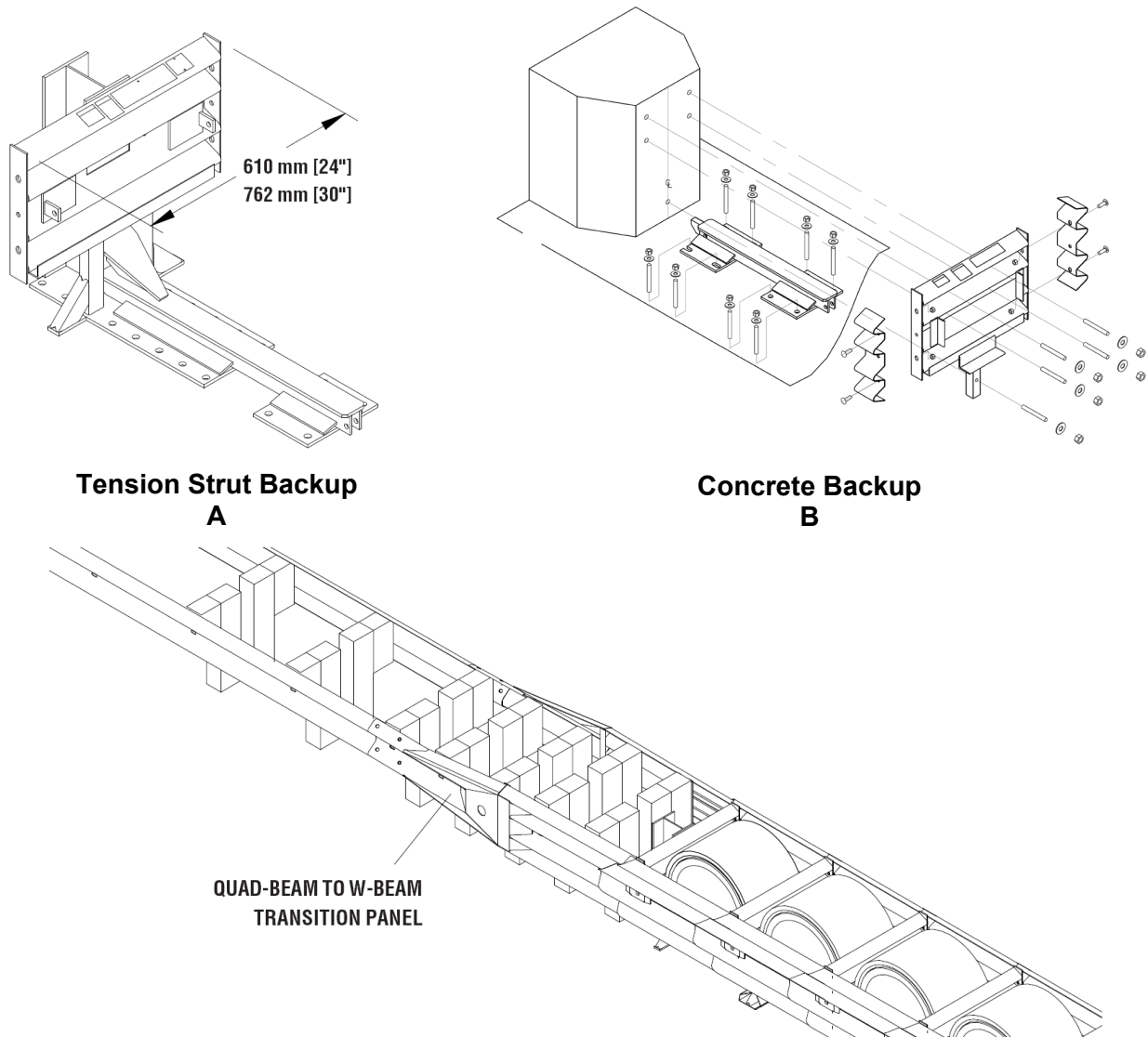

Figure 6
Transitioning the QuadGuard Elite



Figure 7
Side Panel

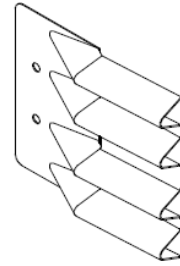

Figure 8
Quad-Beam End Shoe

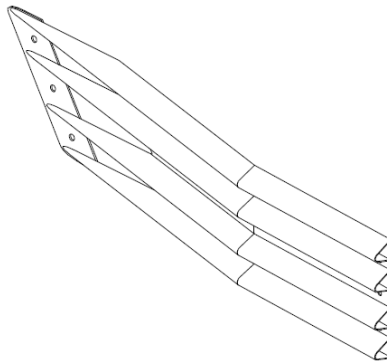

Figure 9
Quad-Beam to Safety Shape

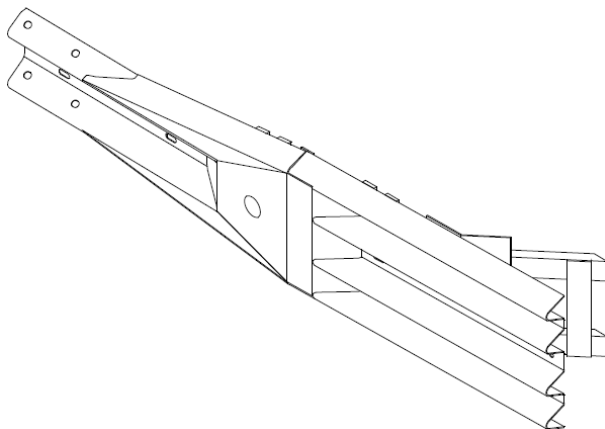

Figure 10
Quad-Beam to W-Beam Transition Panel

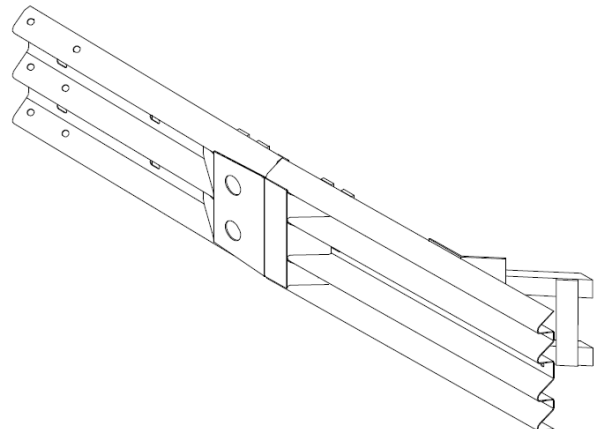

Figure 11
Quad-Beam to Thrie-Beam Transition Panel



Important: The appropriate Transition Panel or Side Panel must be used to achieve system performance pursuant to NCHRP Report 350 tested criteria. The correct panel to use will depend on the direction of traffic and what type of road feature the QuadGuard® Elite is shielding. Contact the Customer Service Department prior to assembly if you have any questions (p. 3).

2) Mark System Location



Warning: Ensure proper site grading for QuadGuard® Elite placement as dictated by the state or specifying agency, pursuant to AASHTO guidelines.

Locate the centerline of the system by measuring the proper offset from the roadside obstacle. See the drawing package supplied with the system. Place chalk line to mark the centerline of the system. Mark a construction line parallel to the center line and offset 6.5" [165 mm] to one side as shown in Figure 12. The edge of the Monorail will be placed on this line.

Note: The concrete pad shall comply with the project plans supplied with the system.



Warning: Location of system to the fixed object is critical and dependent on the Transition Panel. See the project plans supplied with the system for details.



Figure 12
(Top view of concrete pad)
Locating Construction Line

3) Anchor the Backup and Monorail

See Figure 13 (showing Backup Assembly) and Figure 15 (showing Monorail deployment). Also refer to the drawing package and the Approved Adhesive section (p. 10).

An approved adhesive anchoring system is required to securely anchor crash cushions and other common highway devices. Valtir approved adhesive features high pullout strength, superior vibration resistance, and exceptional durability. Each approved adhesive kit contains adhesive, studs, nuts and washers. Both vertical and horizontal assemblies are possible using an approved adhesive anchoring system.

A) Tension Strut Backup Assembly (Figure 13)

Locate the Backup and Monorail on the pad with the side of the Monorail on the construction line (Figure 15). Verify that applicable Transition Panels fit properly before anchoring the Backup. Drill anchor holes in foundation using the Backup as template. Anchor the Backup to the concrete foundation using an approved adhesive supplied with the QuadGuard® Elite (p. 10).

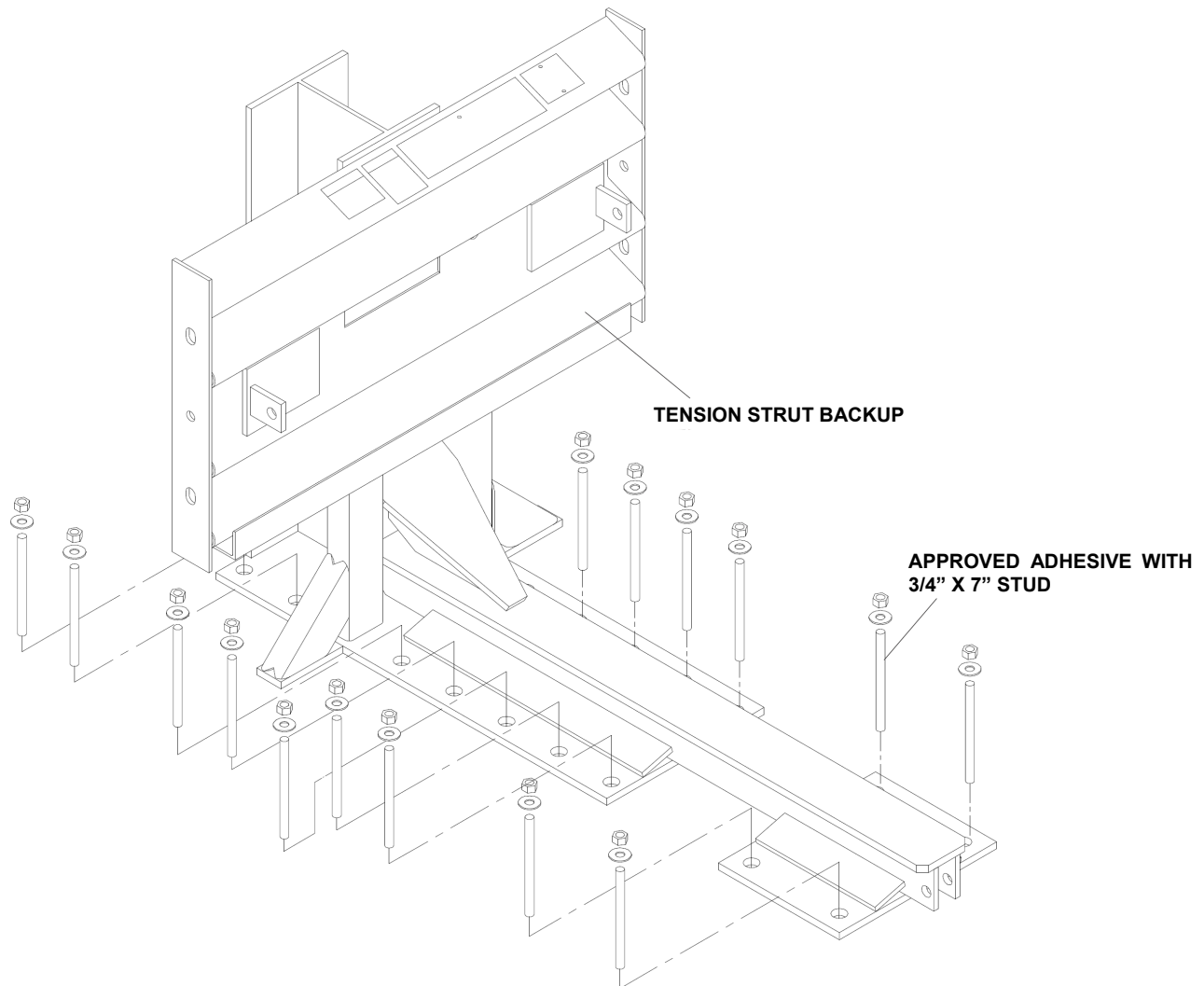

Figure 13
Anchoring Tension Strut Backup to Foundation

B) Monorail Assembly

Locate the Monorail on the construction line as shown in the Monorail Assembly drawings. Drill 5 1/2" [140 mm] deep anchor holes using the Monorail as a template (Figure 15). Do not drill through pad. Anchor each Monorail section using an approved adhesive. See below and approved anchoring instructions (p. 8). It is important to attach and align each segment of Monorail starting from the back and working toward the front of the system ($\pm 1/4"$ [6 mm]).



Warning: Improper alignment at the Monorail Splice Joints will prevent proper collapse during system impact.



Warning: Every hole and slot in Backup and Monorail must be anchored by a stud using an approved adhesive.

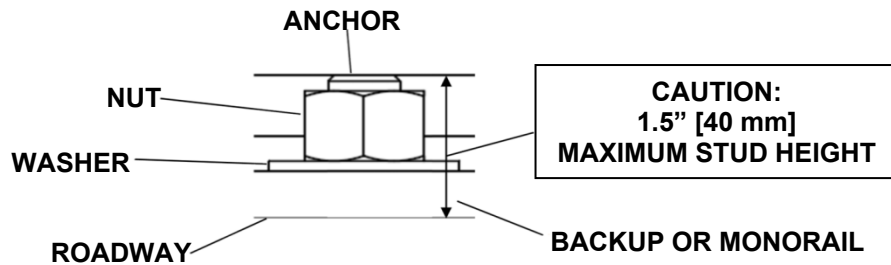

Figure 14
Proper Stud Height
(After Applied Torque)

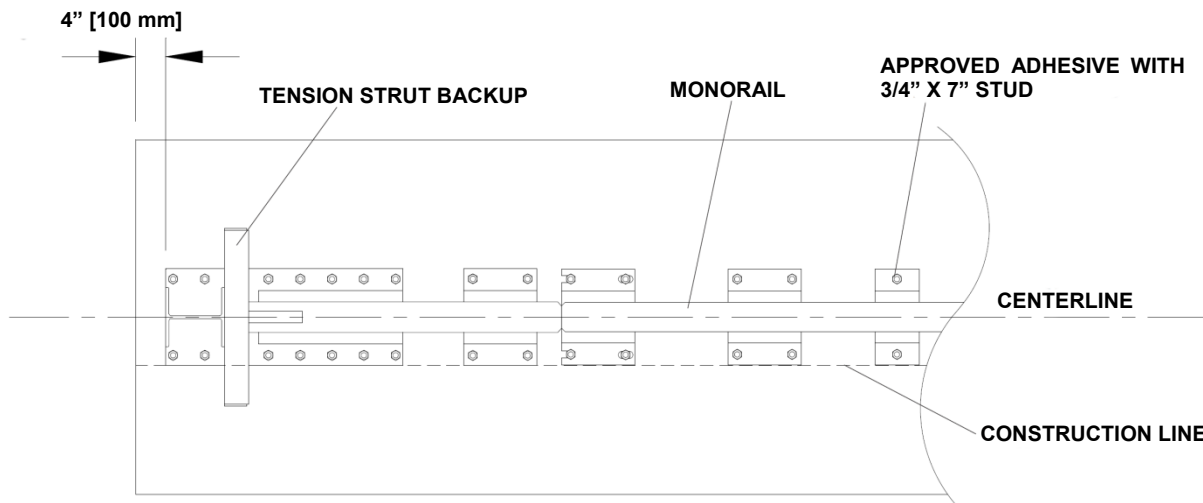

Figure 15
Backup and Monorail Location for Tension Strut Backup

4) Attach Side Panels / Transition Panels to Backup Assembly

Attach the Transition Panel or Side Panel as appropriate to each side of the Backup. Refer to Figure 16 and the drawing package for more information.

Note: A Side Panel is not needed when a Transition Panel is used.

5) Attach Monorail Guides

Attach Monorail Guides to Diaphragms as shown in Figure 17, and the Diaphragm Assembly drawing.

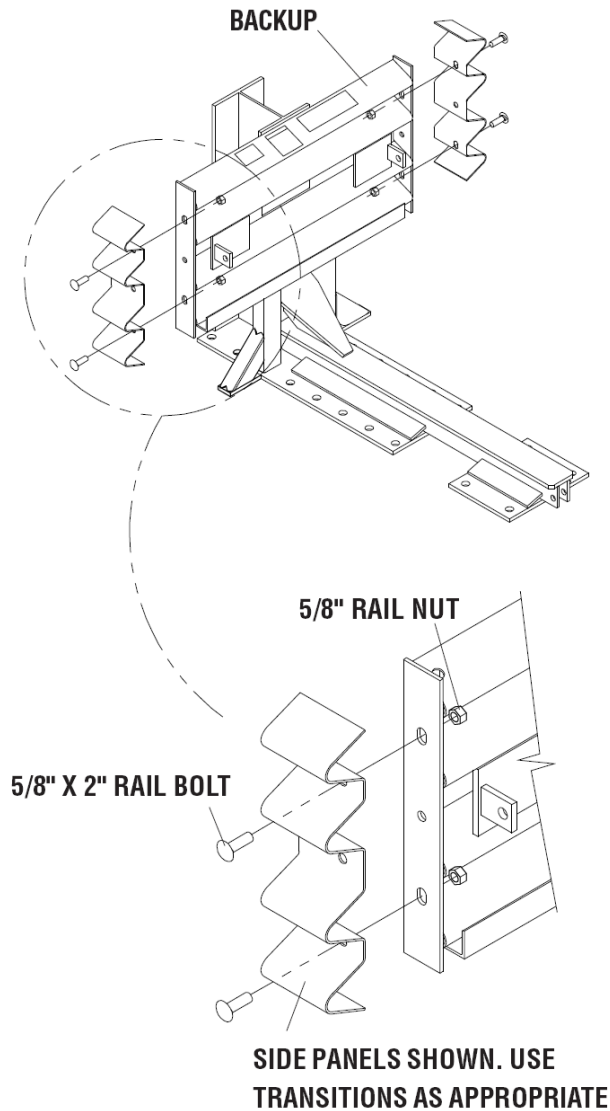

Figure 16
Side Panel/Transition Panel Attachment

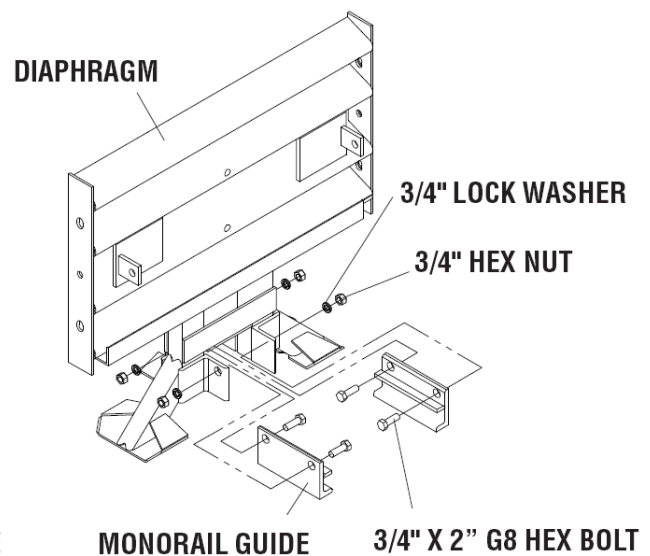

Figure 17
Monorail Guide Attachment

6) Attach Diaphragms

Orient a Diaphragm so that the front face of the quad-beam shape faces toward the Nose of the system as shown in Figure 18. Slide one Diaphragm all the way to the Backup to ensure the system is able to collapse properly during impact. Once this has been verified, slide the Diaphragm forward to approximately 35" [890 mm] in front of the Backup.

Orient and slide all other Diaphragms (except the first three) onto Monorail and position each approximately as shown in Figure 19.

Diaphragms 1, 2 & 3 each have Bumpers attached to them. Orient Diaphragms 3, 2 & 1 with the Bumpers as shown in Figure 19 and the front face of the quad-beam shape facing toward the Nose of the system as shown in Figures 18 and 19.

Slide Diaphragms 3, 2 & 1 onto the Monorail and space as shown in Figure 19.

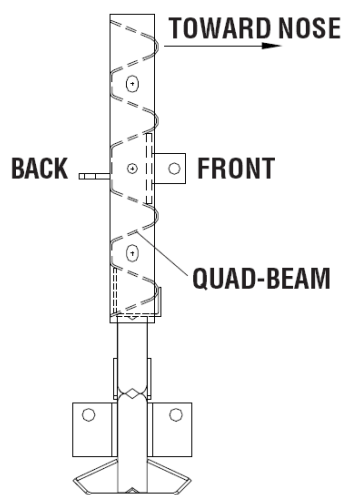

Figure 18
Diaphragm Orientation

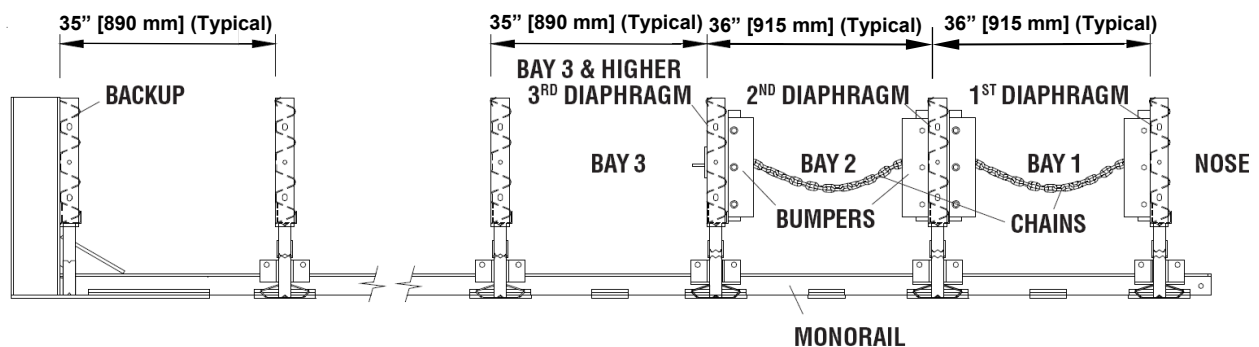

Figure 19
Diaphragm spacing

7) Cylinder Assembly

All QuadGuard® Elite systems utilize a specific Cylinder configuration. Each system may be equipped with up to two (2) different types of Cylinders (Figure 20). See illustrations on pages 26 and 27 with corresponding Cylinder configurations depending on the number of Bays.

Bays 1 and 2 are always empty.

Bays 3 to 5 contain a single walled 32" [813 mm] outside diameter Cylinder with QE1 stenciled on the outer surface.

When systems have more than five Bays, the remaining Bays contain double walled 32" [813 mm] outside diameter Cylinders with QE2 stenciled on the outer surface.

Note: The Nose Assembly contains a single walled 28" [711 mm] outside diameter Cylinder with QEN (QuadGuard® Elite Nose) stenciled on the outer surface.



Warning: Placing the wrong Cylinder in the Nose or any Bay has not been crash tested pursuant to NCHRP Report 350 criteria. Accordingly, this is likely to result in unacceptable crash performance as described in NCHRP Report 350.



Figure 20
QE1 & QE2 Cylinders w/Labels

8) Place Rear-most Cylinder

Beginning at the Backup, locate and position a Cylinder such that it is centered resting on the Monorail.

Slide the rear-most Diaphragm towards the Cylinder such that no gaps exist between the backup, the Cylinder, and the Diaphragm.

Thread the 1/2" [13 mm] diameter wire rope around the Backup structure, the Cable Jacketing Tube, and the center of the Cylinder as shown in Figure 21.

Attach ends of cable using (2) 1/2" [13 mm] Cable Clamps as shown in Figure 21. The Cable Clamps should be separated by approximately 102 mm [4"] as shown.

Remove excess slack from the cable prior to tightening the Cable Clamps evenly to 65 ft-lbf [88 N m].

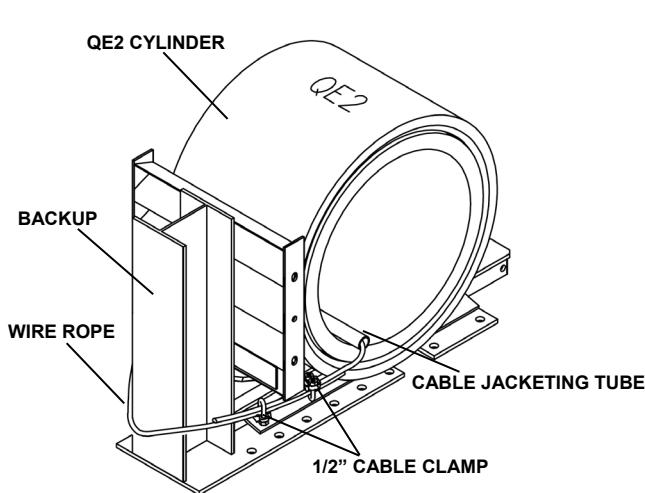

Figure 21
Cylinder Assembly
(Fender Panels, Rear Diaphragm, and Second Cable not shown for clarity)

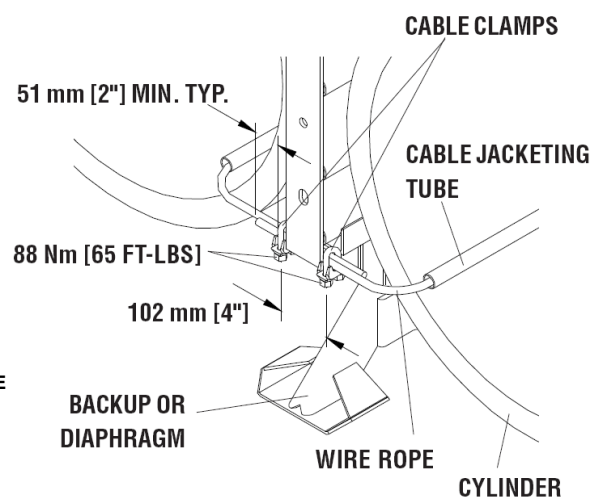

Figure 22
Typical Cable Clamp Assembly
(Fender panels not shown for clarity)

9) Attach the Remaining Cylinders

Continue attaching the Cylinders to their common diaphragms using the 1/2" cable, Cable Clamps, and Cable Jacketing Tube as shown in Figure 21 above.

Work forward from the Backup.

Be sure to remove any clearance between the Cylinders and their adjacent Diaphragms prior to removing all the possible cable slack and tightening the Cable Clamps.

Except where otherwise noted, the Cable Jacketing Tube should be centered within the length of the Cylinders as shown to prevent the cable from damaging the Cylinders.

10) Attach the QE1 Cylinders

There is no Cylinder in Bays 1 & 2; therefore the 1/2" diameter cable just wraps around the legs on the front of the third Diaphragm (Figure 23c on p. 27).

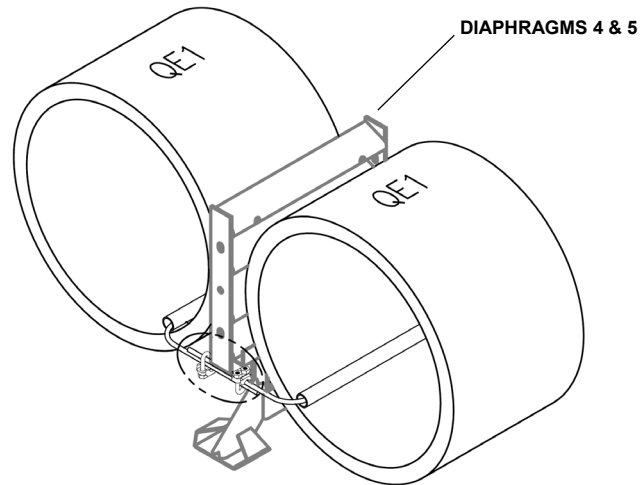

Figure 23a
Typical Cylinder Mounting

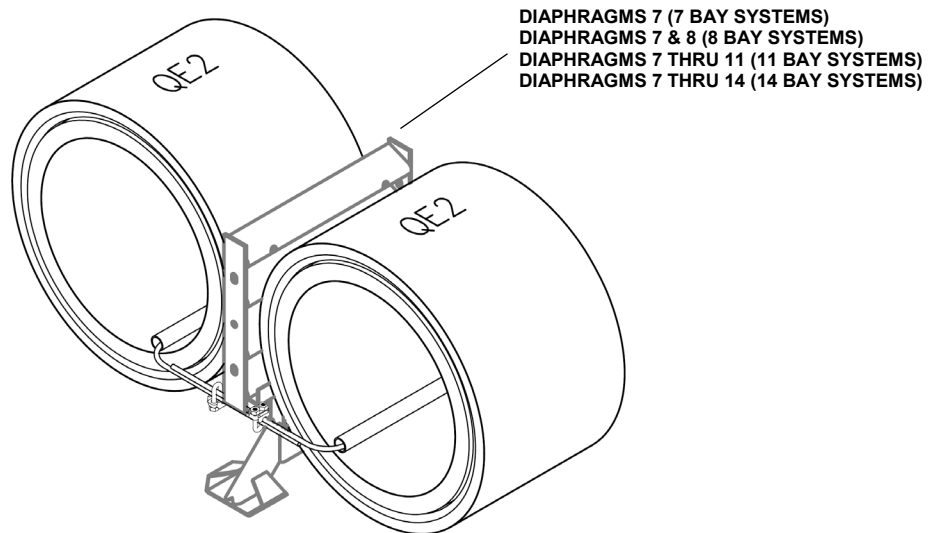

Figure 23b
Typical Cylinder Mounting

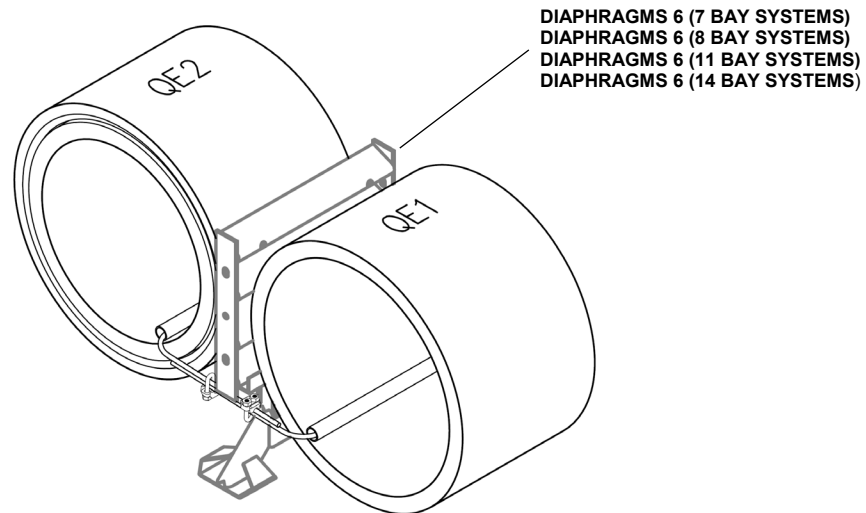
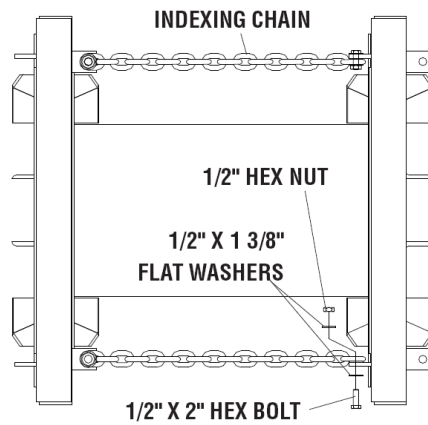

Figure 23c
QE1 Cylinder Mounting to 3rd Diaphragm

11) Attach Indexing Chains

For the 36" system, Bays three and higher toward the backup use (2) Indexing Chains in each Bay.



TOP VIEW

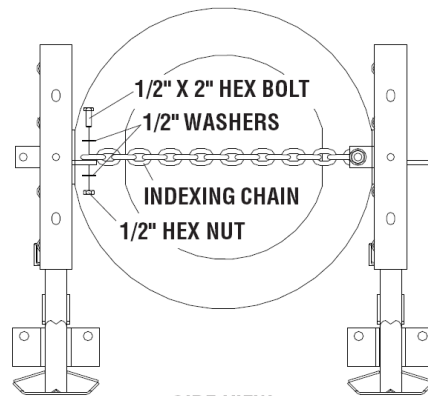

SIDE VIEW

Figure 24
Attach Indexing Chains
(Fender Panels not shown for clarity)

12) Attach End Cap

Attach End Cap to the Monorail as shown in Figure 25 and the Monorail Assembly drawing.

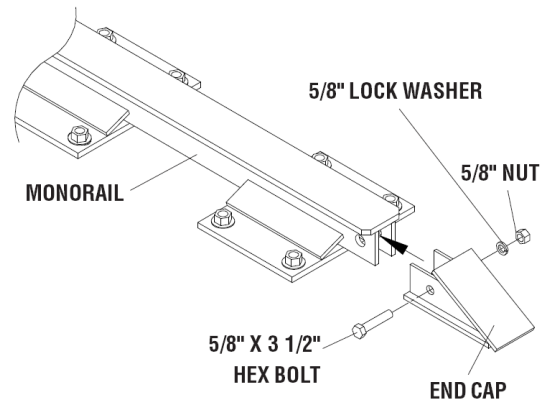

Figure 25
End Cap Attachment

13) Attach Fender Panel(s)



Important: Do not mix the 5/8" rail nuts (large) with the 5/8" hex nuts (small) (Figure 26).

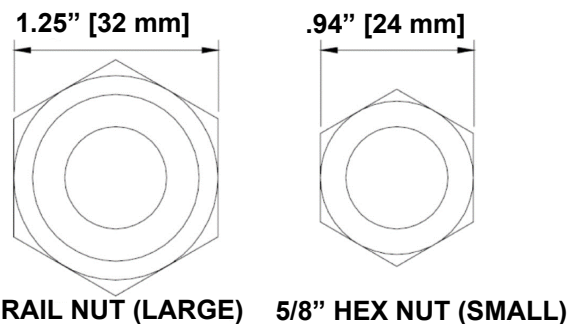

Figure 26
Rail Nuts are Oversized

Starting at the Backup and working forward, assemble left and right Fender Panels as shown in Detail 26a and Fender Panel drawing.

- A. Place the Fender Panel so that the center hole of the rearward Diaphragm is lined up with the approximate center of the slot in the Fender Panel.
Attach Mushroom Washer Assembly as shown in Figure 28 (p. 27), but do not torque at this time as this step helps to balance the Fender Panel later.
- B. Slide the Fender Panel forward until the holes in the Fender Panel line up with the holes in the forward Diaphragm.
- C. Use a drift pin to align the center hole of the Fender Panel with the center hole of the Diaphragm.
- D. Attach the front of the Fender Panels to the next Diaphragm using two (2) rail bolts and large hex nuts per side. Use only the top and bottom holes; leave the center hole open until the next Fender Panel is attached.

Continue attaching Fender Panels until you reach Diaphragm No. 2. Figure 27 shows the location of Diaphragm No. 2.

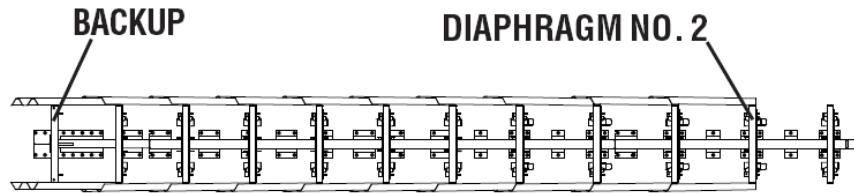
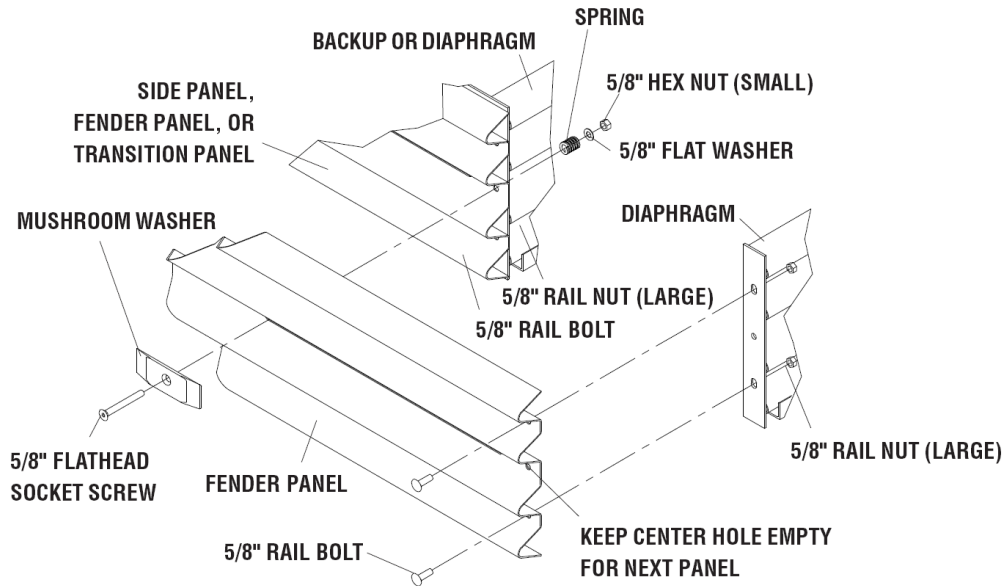
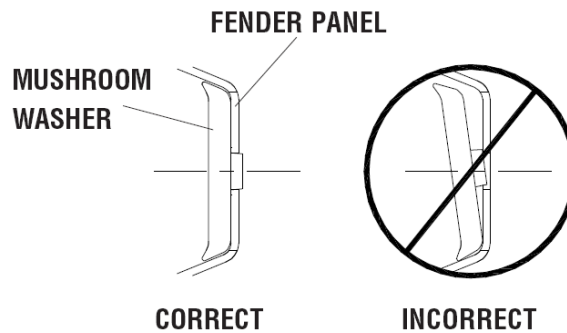

Figure 27
Locate Diaphragm No. 2



Detail 28
Fender Panel Assembly

Ensure Mushroom Washers lay flat against the Fender Panel as shown below. Standoff on Washer must be seated completely through slot (Detail A).



Detail A

14) Attach Nose Cylinder

Attach the Nose Cylinder using two (2) 5/8" x 10" long threaded rods through the Nose Cylinder Plate, Nose Cylinder, Diaphragm, and Chain Mount Bracket (Figure 29). Tighten each 5/8" threaded rod with flat washers and nuts to 20 ft-lbf [27 N·m] minimum, 25 ft-lbf [34 N·m] maximum.

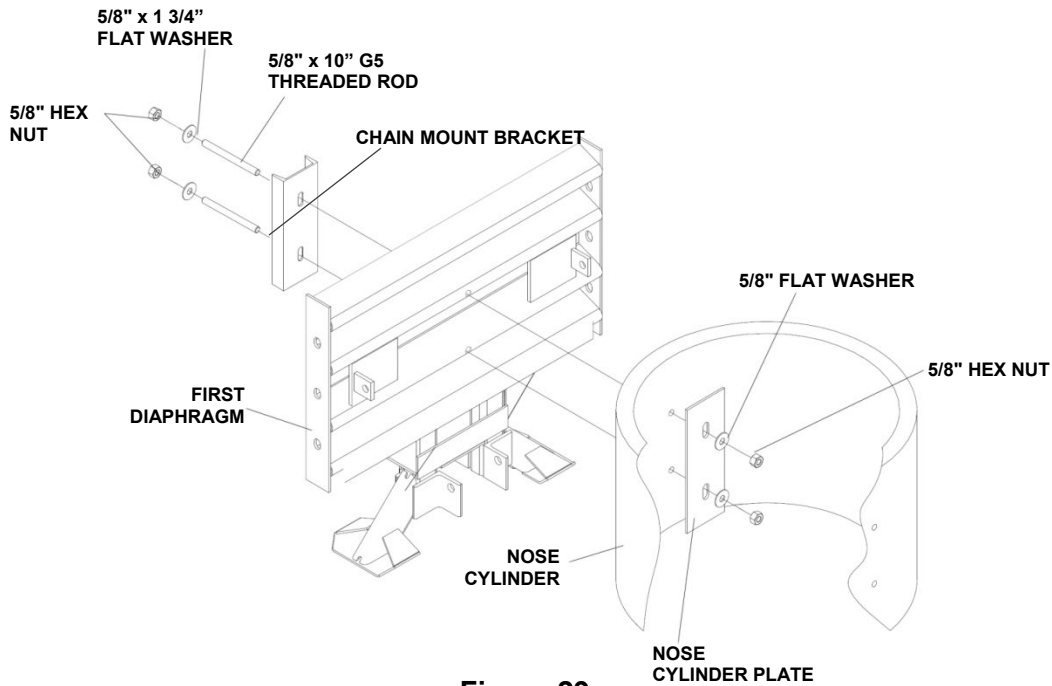

Figure 29
Attach Nose Cylinder to First Diaphragm

For the 24", 30" & 36" systems Bays 1 & 2, use one Indexing Chain in each Bay. Attach Indexing Chains using 1/2" diameter x 2" long hex head bolts, nuts & washers (Figure 30).

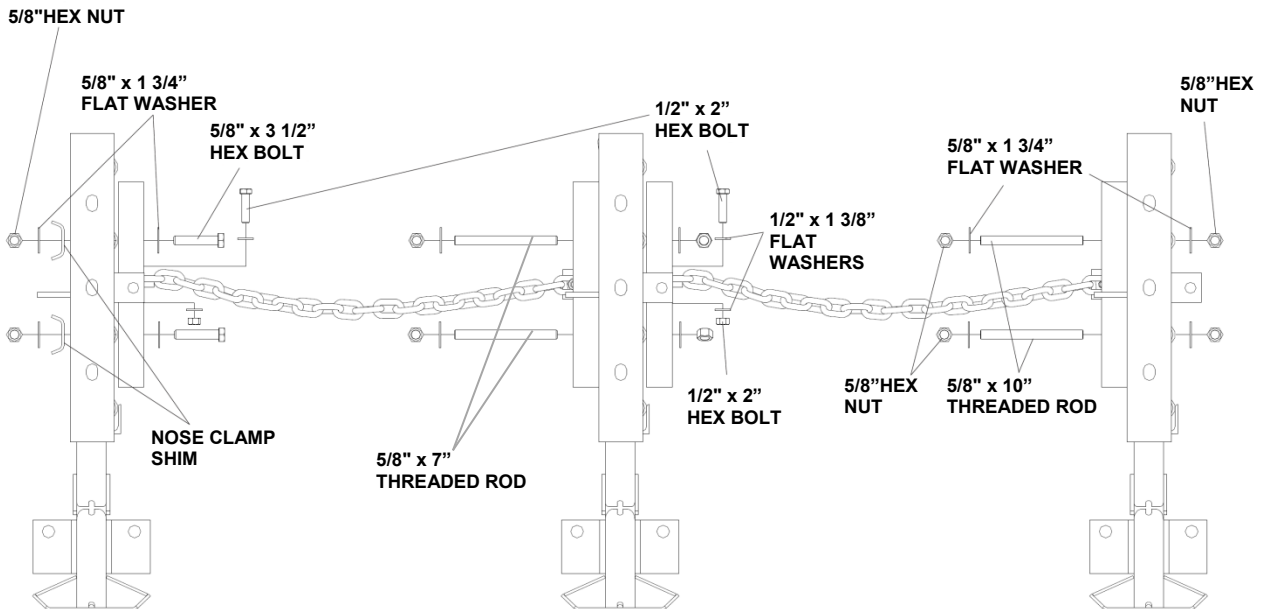

Figure 30

15) Assemble Bumper Belt Assemblies

Bays 1 and 2 of the 24", 30", and 36" wide systems are outfitted with Bumper Belt Assemblies as shown in Figure 31 & Detail 31a, 31b, and 31c. Attach two (2) Bumper Belt assemblies to the back of the first Diaphragm and the front of the third Diaphragm. First, orient Tube Spacers so the larger holes face out as shown in Detail 31c and attach the Tube Spacers to the Diaphragms using the two (2) 1/2" x 2" hex bolts, nuts, and 1/2" x 1 3/8" flat washers. Next, attach one side of the flexible Bumper Belt to a Tube Spacer using three (3) 3/8" x 4 1/2" long mounting bolts. Wrap the Bumper Belt around the Tube Spacer affixing its opposite side with the nut/washer combination shown in Detail 31a & 31c. Torque the mounting bolts to 20 ft-lbf [27 N·m]. The second Diaphragm uses 1/2" x 5" Hex Bolts, nuts, and washers to attach Tube Spacers to each side of the Diaphragm. Repeat flexible Bumper Belt Assembly for each Tube Spacer. Attach Fender Panels including the stop tabs on the second and third Diaphragm.

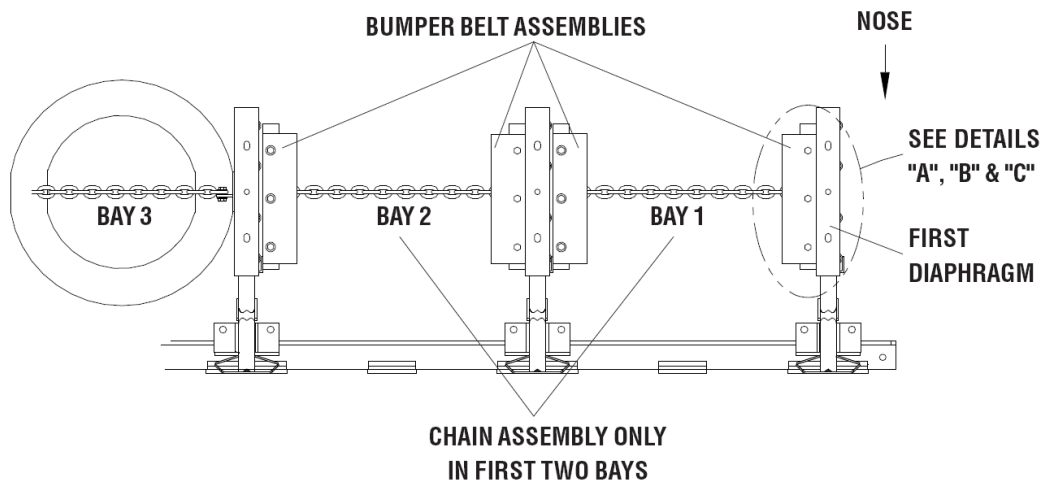
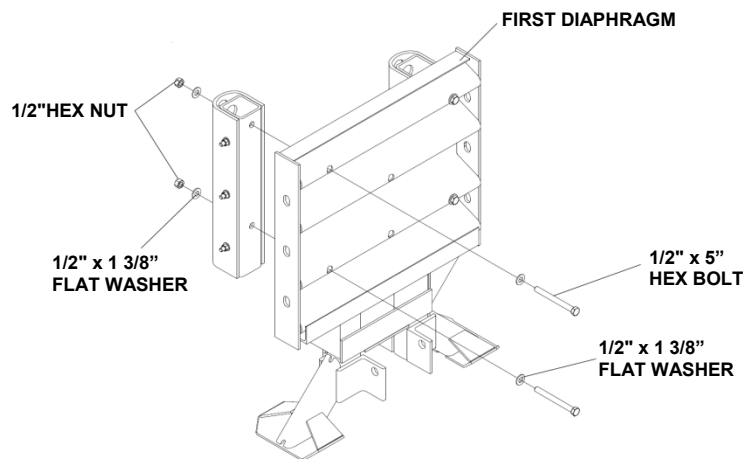
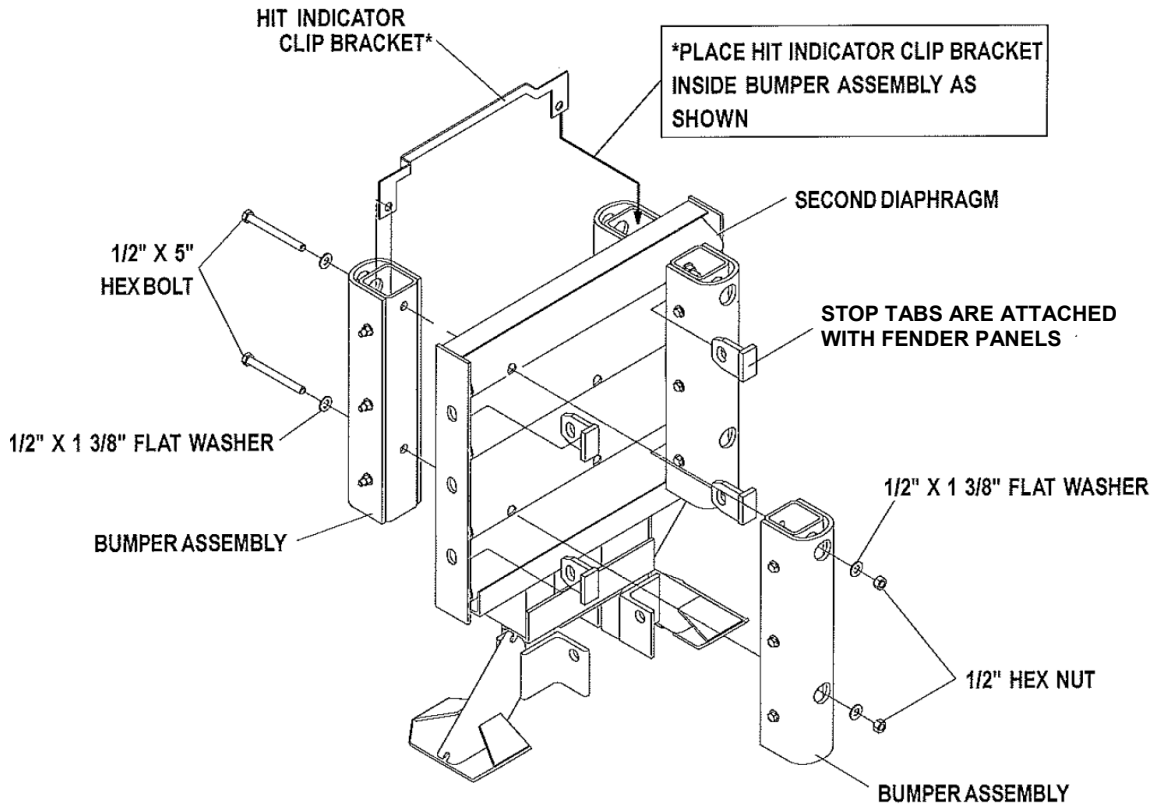

Figure 31
Bumper Belt Assembly



Detail 31a



Detail 31b

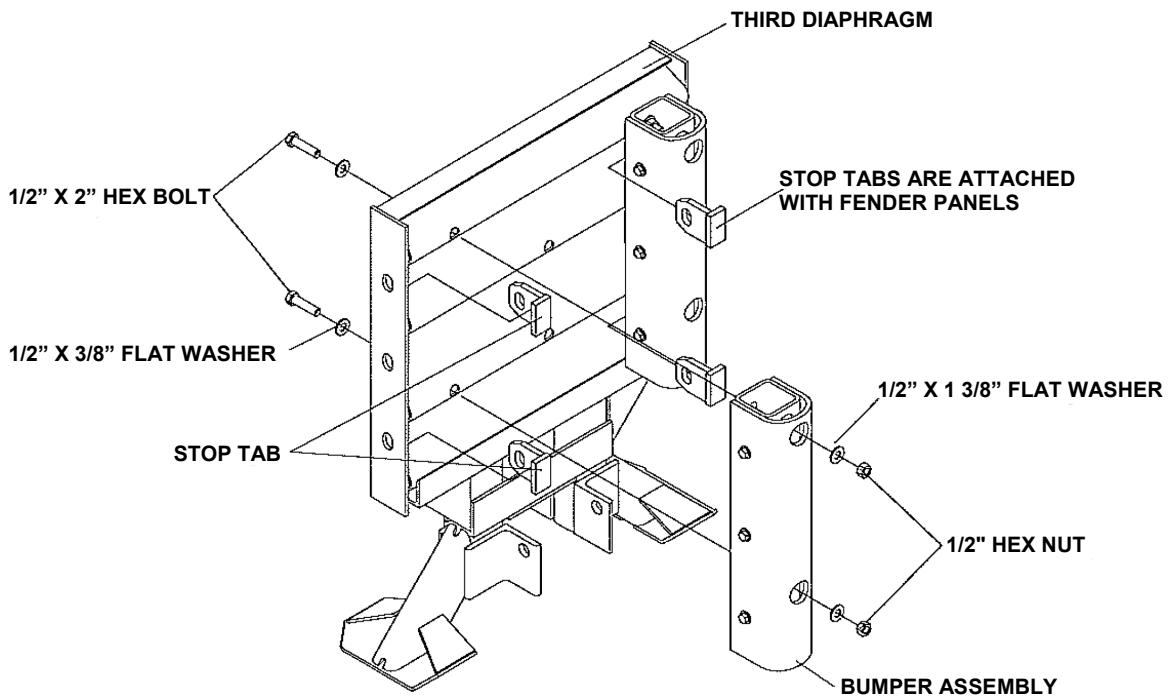

Detail 31c

16) Attach Belt Nose

Finally attach the Nose Belt to the Fender Panels using six (6) 5/8" x 2" long hex head bolts, (24) 5/8" flat washers, and (18) 5/8" hex nuts through the Belt Clamps (Figure 32).

The Nose of the system may be delineated to comply with local codes (chevron, reflectorized sign, etc.).



Warning: Placing the wrong type Cylinder in the Nose or any Bay **will** result in unacceptable crash performance as described in NCHRP Report 350.

Adjust the hex nuts so that the faces of the flat washers are flush with the outside humps of the Fender Panels (Figure 32).

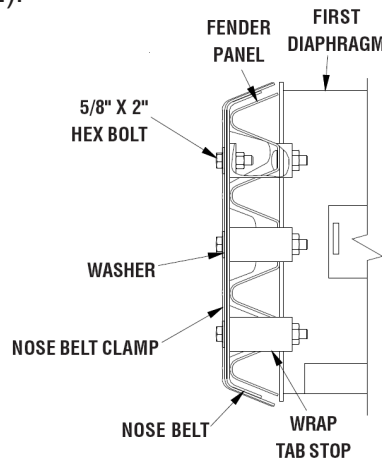

Figure 32

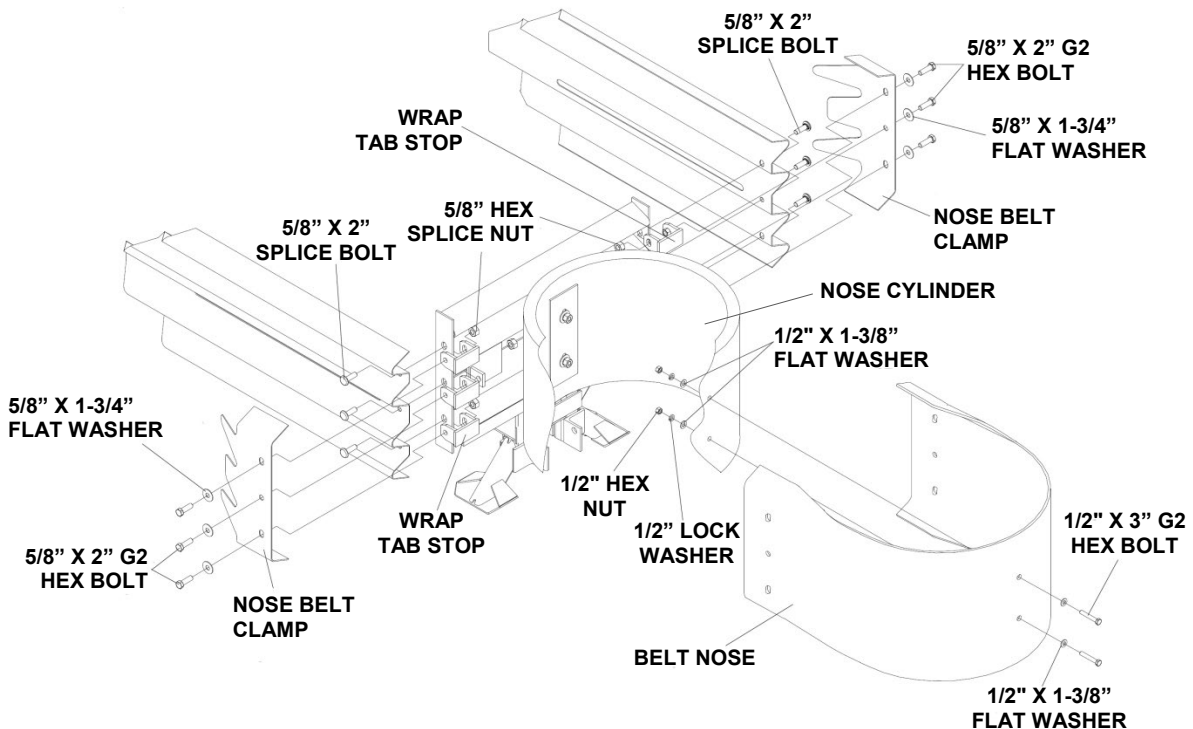

Figure 33
Attach Nose Belt to Fender Parts

17) Attach Hit Indicator to Diaphragm No. 1

The Hit Indicator should be the last component attached to the system. Center and bolt the Hit Indicator to the first Diaphragm with the hardware provided as shown in Figure 34.

Rotate the Hit Indicator to its horizontal position and lock it into position by bending the Trigger Clip around the top of the second Diaphragm (Figure 35).

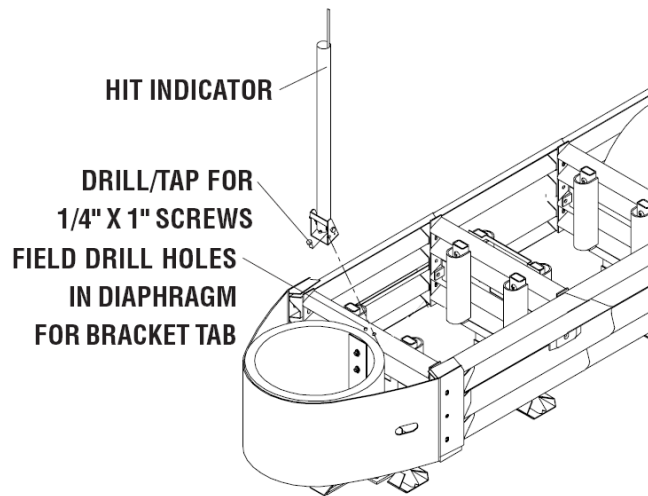

Figure 34
Attach Hit Indicator

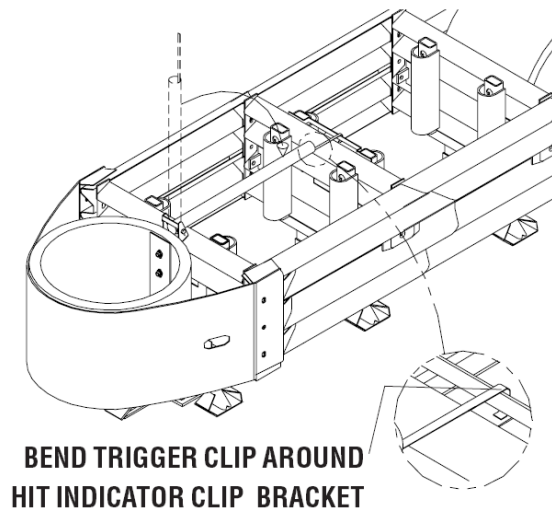

Figure 35
Rotate Hit Indicator/Bend Trigger Clip

18) Checking The System Assembly

At this point tighten all Mushroom Bolts and recheck to ensure that all fasteners are properly tightened throughout the system per table below. Check all Fender Panels. If they do not fit tightly against the underlying panel, system realignment may be necessary (p. 35).



Caution: Ensure QuadGuard® Elite installation and delineation meet all appropriate Manual on Uniform Traffic Control Devices (“MUTCD”), federal, state, specifying agency, and local specifications.



Warning	
Mushroom Bolt Assemblies	Torqued to 60 ft-lbf [80 N·m]
Anchor Studs	Torque to manufacture specification. Shall Not protrude above nuts (Figure 14 on p. 21)
All Other Bolts	Tightened
Fender Panel	Maximum gap allowed: Narrow Systems – 0.78” [20 mm] Wide Systems – 1.00” [25 mm]
Cable Clamps	Torque to 65 ft-lbf [84 N·m]

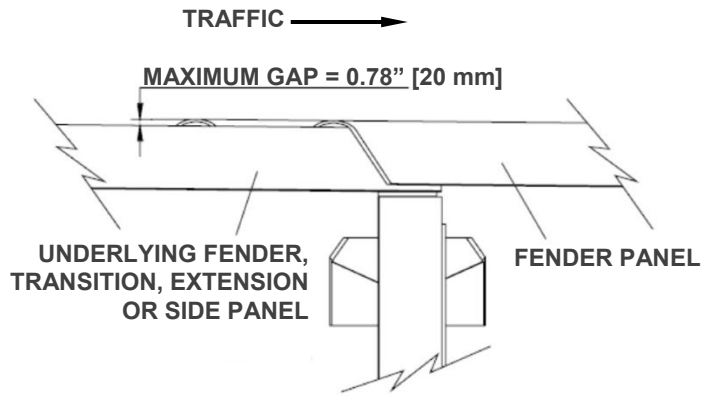
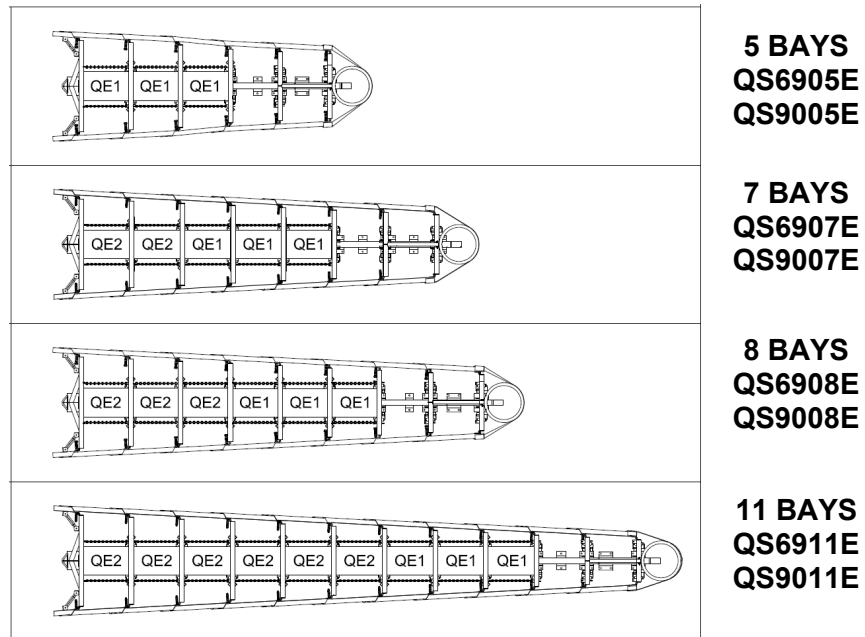

Figure 36
Fender Panel Gap for Narrow Systems

19) Inspect System

Inspect the system in accordance with the QuadGuard® Elite Maintenance Flow Chart on page 61.

QuadGuard® Elite for Wide Roadside Obstacles



Assembly

Site Preparation/Foundation



Warning: Ensure that this assembly conforms with the guidance provided by the AASHTO Roadside Design Guide, including, but not limited to, those regarding placement on or adjacent to curbs.

A QuadGuard® Elite should be deployed only on an existing or freshly placed and cured concrete base (4000 psi [28 MPa] minimum). Location and orientation of the concrete base and attenuator must comply with project plans or as otherwise determined by the resident project engineer.

Recommended dimension and reinforcement specifications for new concrete pads are provided in the Valtir concrete pad drawing supplied with system. The system may be deployed on a non-reinforced concrete roadway (minimum 8" [200 mm] thick). Concrete base cross-slope shall not exceed 8% and no more than 2% over the length of the system; the foundation surface shall have a light broom finish.



Caution: Accurate placement of all steel rebar is critical to avoid interference with the Concrete Anchor Bolts.



Warning: Location of the Backup in relation to nearby objects will affect the operation of the attenuator. Upon impact, the Fender Panels telescope rearward and extend beyond the rigid Backup as much as 25" [635 mm] from their pre-impact location. Position the Backup so that the rear ends of the last Fender Panels are a minimum of 25" [635 mm] forward of objects that would otherwise interfere with movement of the panels. Failure to comply with this requirement is likely to result in system performance which has not been crash tested pursuant to NCHRP Report 350 criteria and may also cause component damage which will necessitate maintenance or replacement of the system.



Inspect Shipping

Before deploying the QuadGuard® Elite, check the received parts against the shipping list supplied with the system. Make sure all parts have been received.

Assembly Steps

Note: The Drawing Package supplied with the QuadGuard® Elite must be used with these instructions for proper assembly and should take precedence over these general instructions.

1) Determine Backup & Transition Type

The QuadGuard® Elite **Wide** uses a Tension Strut Backup.

A Transition Panel or Side Panel must be used for the system to perform as crash tested on each side of the Backup. A Side Panel is not needed when a Transition Panel is used. Several types of transitions are available for use with the QuadGuard® Elite Wide. Refer to Figures 39 through 43 and the Drawing Package to determine which types of panels are being attached.

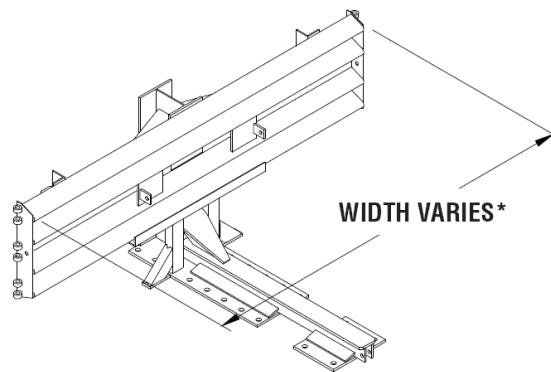

64" [1620 mm] for 69" [1755 mm] Wide System
83" [2100 mm] for 90" [2285 mm] Wide System

Figure 37
Tension Strut Backup

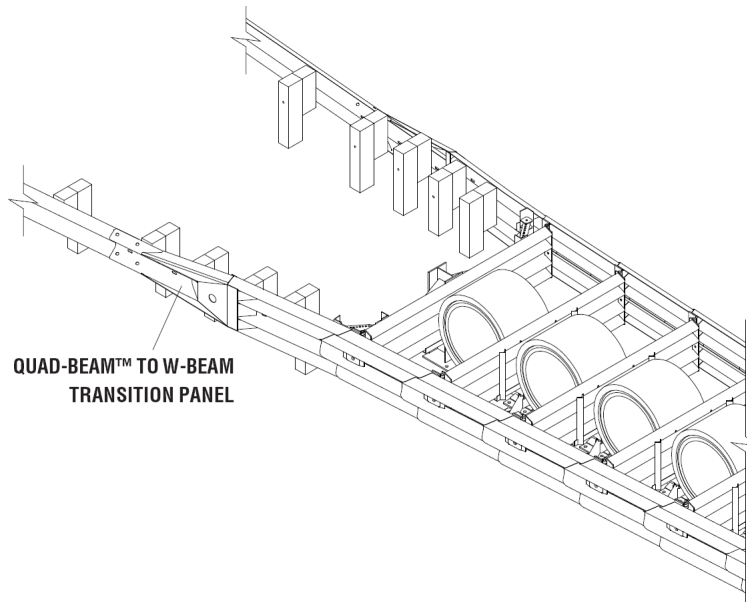

Figure 38
Transitioning the QuadGuard® Elite



Figure 39
Wide Side Panel

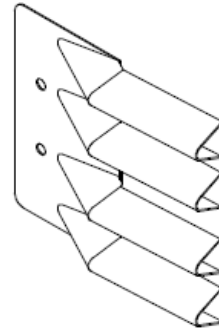

Figure 40
Quad-Beam End Shoe

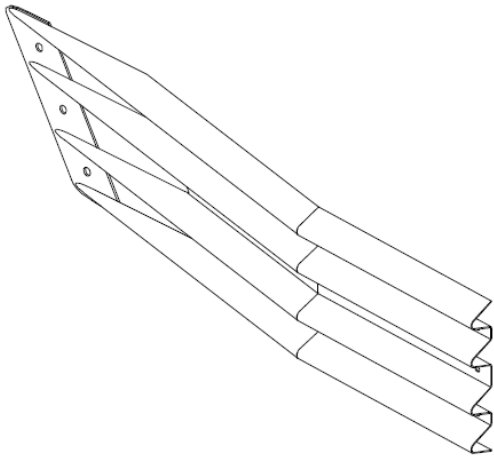

Figure 41
Quad-Beam to Safety Shape Barrier
Transition Panel

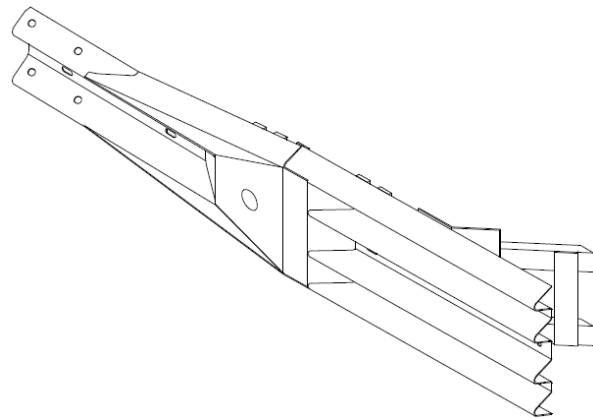

Figure 42
Quad-Beam to W-Beam
Transition Panel

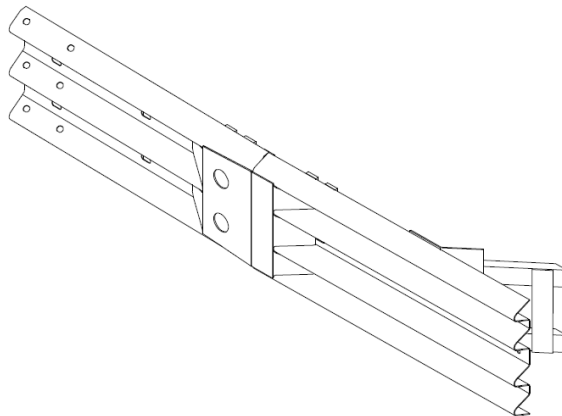

Figure 43
Quad-Beam to Thrie-Beam Transition Panel



Important: The appropriate Transition Panel or Side Panel must be used to achieve system performance pursuant to NCHRP Report 350 tested criteria. The correct panel to use will depend on the direction of traffic and what type of road feature the QuadGuard® Elite is shielding. Contact the Customer Service Department prior to assembly if you have any questions (p. 3).

2) Mark System Location



Warning: Ensure that there is proper site grading for the QuadGuard® Elite placement as dictated by the state or specifying agency, pursuant to AASHTO guidelines.

Locate the centerline of the system by measuring the proper offset from the roadside obstacle. Refer to the drawing package supplied with the system. Place chalk line to mark the centerline of the system. Mark a construction line parallel to the center line and offset 6.5" [165 mm] to one side as shown in Figure 44. The edge of the Monorail will be placed on this line.

Note: The concrete pad should be configured per the project plans supplied with the system.



Warning: Location of system to the fixed object is critical and dependent on the Transition Panel. See the project plans supplied with the system for details.



Figure 44
(Top view of Concrete Pad)
Locating Construction Line

3) Anchor the Backup and Monorail

See Figure 45 (Backup Assembly) and Figure 47 (Monorail diagram). Also refer to the drawing package and the Approved Adhesive Anchoring section (p. 10).

An approved adhesive anchoring system is required to securely anchor this crash cushion and other common highway devices. Valtir approved adhesive features high pullout strength, superior vibration resistance, and exceptional durability. Each approved adhesive kit contains adhesive, studs, nuts and washers. Both vertical and horizontal assemblies are possible using an approved adhesive anchoring system.

A) Tension Strut Backup Assembly (Figure 45)

Locate the Backup and Monorail on the centerline of the pad with the side of the Monorail on the construction line as shown in Figure 45. Verify that the applicable Transition Panels fit properly before anchoring the Backup. Drill 5 1/2" [140 mm] deep anchor holes in the pad using the Backup as a template. Do not drill through pad. Anchor the Backup to the concrete pad using an approved adhesive (p. 10).

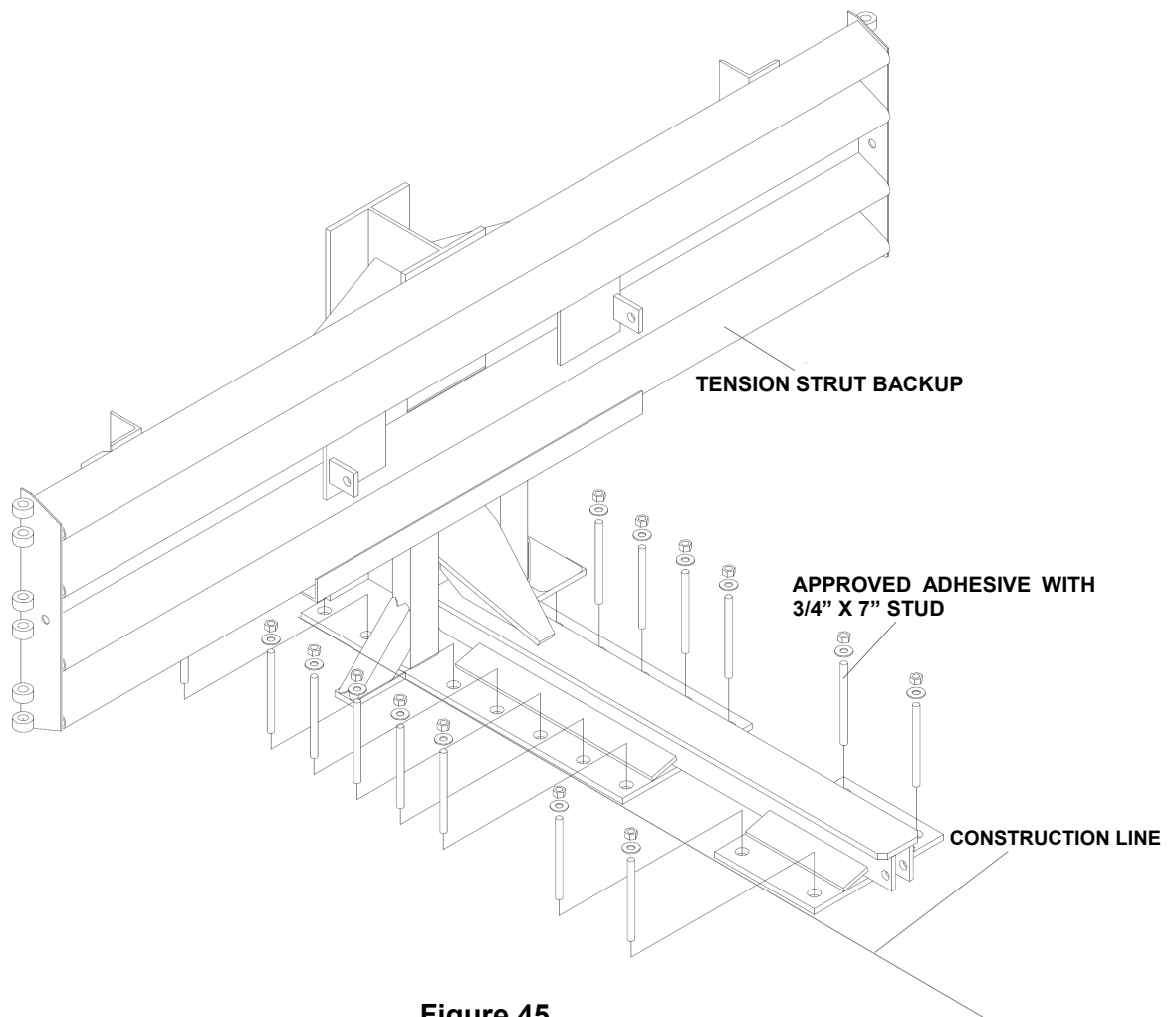

Figure 45
Anchoring Tension Strut Backup to Foundation

B) Monorail Assembly

Locate the Monorail on the construction line as shown in the Monorail Assembly drawings. Drill 5 1/2" [140 mm] deep anchor holes using the Monorail as a template (Figure 47). Do not drill through pad. Anchor each Monorail section using an approved adhesive. See Figure 47 and the Approved Adhesive Anchoring System section of this manual for instructions (p. 10). It is important to assemble each segment of Monorail in alignment from the back to the front of the system ($\pm 1/4"$ [6 mm]).



Warning: Improper alignment at the Monorail Splice Joints will prevent proper system collapse during a NCHRP Report 350 in-criteria impact.



Warning: Every hole and slot in Backup and Monorail must be anchored by a stud using an approved adhesive.

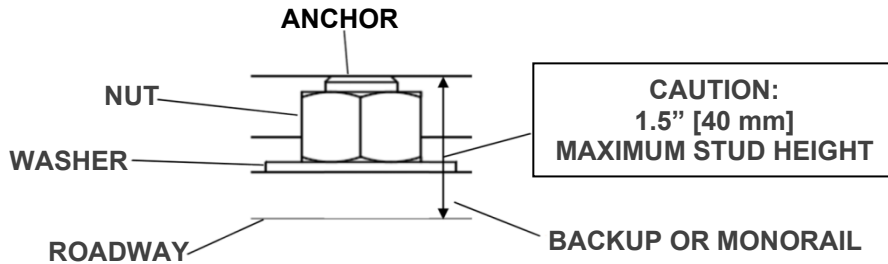

Figure 46
Proper Stud Height
(After Applied Torque)

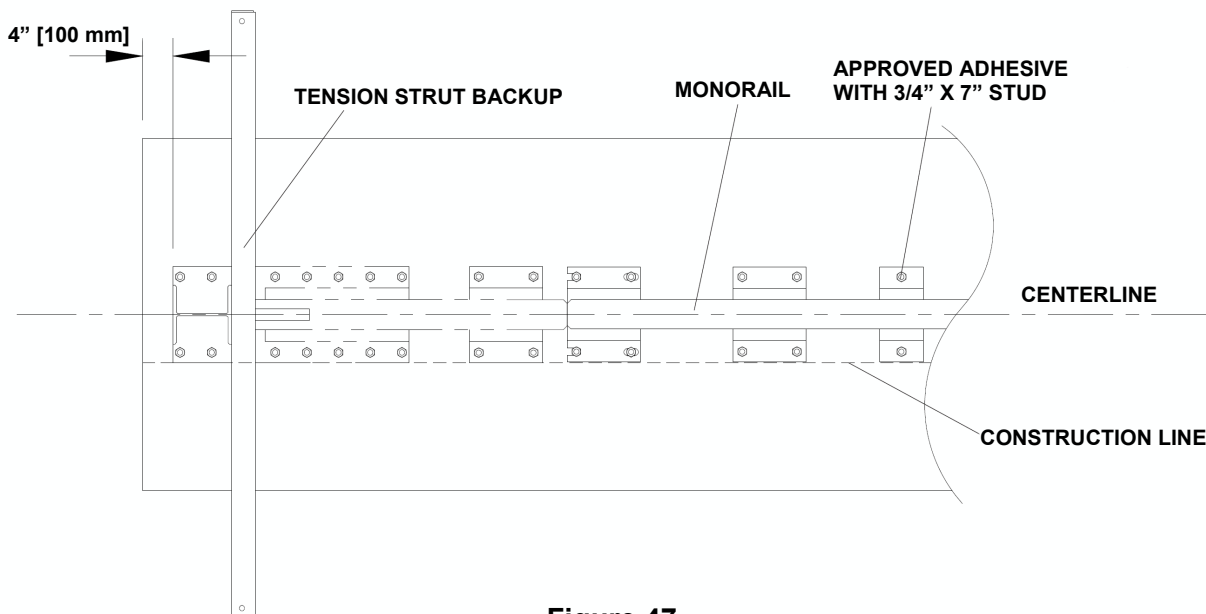

Figure 47
Backup and Monorail Location for Tension Strut Backup

4) Attach Side Panels / Transition Panels to Backup Assembly

Attach the Transition Panel or Side Panel as appropriate to each side of the Backup. See Figure 49 and drawing package for more information.

Note: A Side Panel is not needed when a Transition Panel is used.

5) Attach Monorail Guides

Attach Monorail Guides to Diaphragms as shown in Figure 48, and the Diaphragm Assembly drawing.

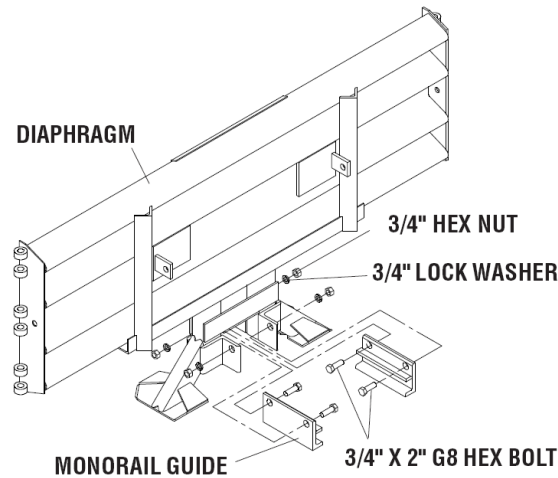

Figure 48
Monorail Guide Attachment

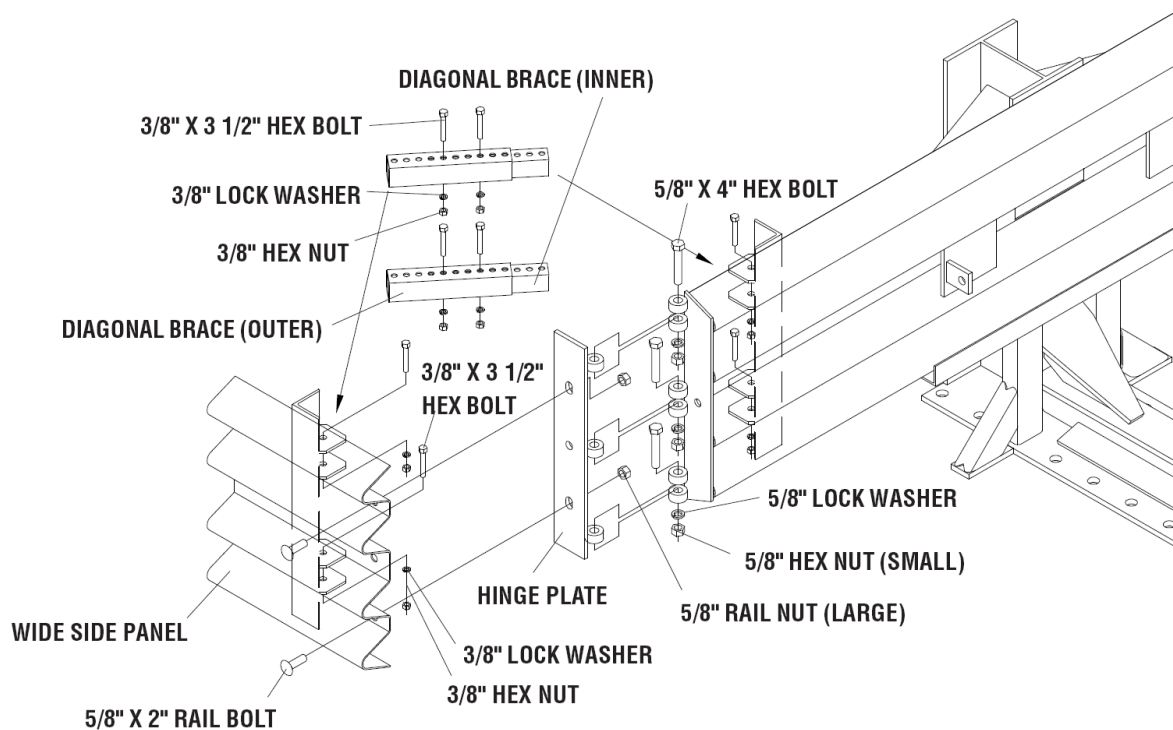

Figure 49
Side Panel/Transition Panel Attachment for Wide Applications

6) Attach Diaphragms

Orient Diaphragms so that the front face of the quad-beam shape faces toward the Nose of the system as shown in Figure 50. The widest Diaphragm is placed closest to the Backup while each subsequent Diaphragm is progressively narrower.

Slide the widest Diaphragm onto the Monorail and all the way to the Backup to ensure system is able to collapse properly during impact. Once this has been verified, slide the Diaphragm forward to approximately 35" [889 mm] in front of the Backup. See Figure 51 for the proper location.

Orient and slide all other Diaphragms (except the first three) onto the Monorail and position each as shown in Figure 51. The Diaphragm spacing shown below prepares the system for assembly.

Diaphragms 1, 2 & 3 each have bumpers attached to them. Slide the three Diaphragms onto the monorail with the bumpers as shown below in Figure 51. The front face of the quad-beam shape will be facing toward the Nose of the system as shown in Figures 50 and 51.

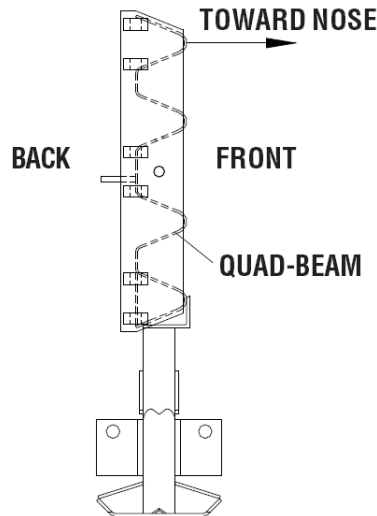

Figure 50
Diaphragm Orientation

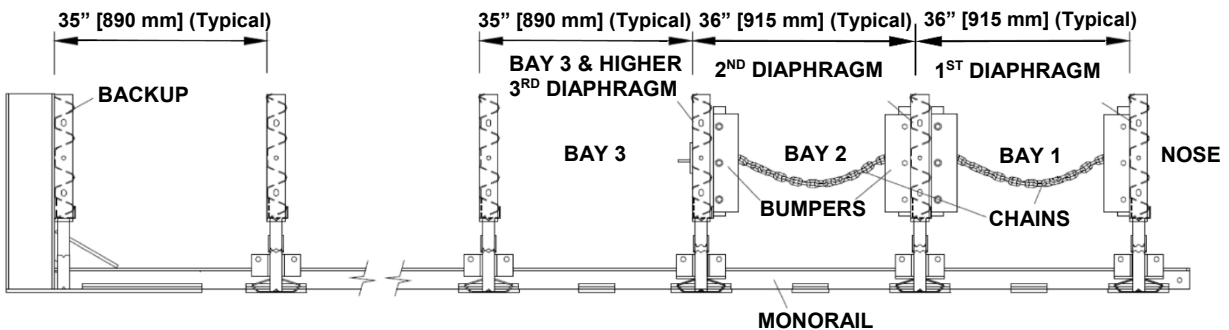

Figure 51
Diaphragm spacing

7) Cylinder Assembly

All QuadGuard® Elite systems utilize a specific Cylinder configuration. Each system may be equipped with up to three different types of Cylinders. See Figure 52 with corresponding Cylinder configuration depending on the number of Bays.

Bays 1 and 2 are always left empty.

Bays 3 through 5 contain a single walled 32" [813 mm] outside diameter Cylinder with QE1 traced on the outer surface (p. 26).

When systems have more than five Bays, the remaining Bays contain double walled 32" [813 mm] outside diameter Cylinders with QE2 traced on the outer surface (p. 26).

The Nose Assembly contains a single walled 28" [711 mm] outside diameter Cylinder with QEN traced on the outer surface.



Warning: Placing the wrong Cylinder in the Nose or any Bay has not been crash tested pursuant to NCHRP Report 350 criteria. Accordingly, this is likely to result in unacceptable crash performance as described in NCHRP Report 350.

8) Place Rear-most Cylinder

Beginning at the Backup, locate and position a Cylinder so it is centered and resting on the Monorail.

Slide the rear-most Diaphragm towards the Cylinder so no gaps exist between the Backup, Cylinder, and Diaphragm.

Thread the 1/2" diameter wire rope around the back face of the Backup structure, the Cable Jacketing Tube, and the center of the Cylinder as shown in Figure 52.

Attach ends of the cable using two (2) 1/2" Cable Clamps as shown in Figure 52. The Cable Clamps should be separated by approximately 4" [102 mm] as shown.

Remove excess slack out of the cable prior to tightening the Cable Clamps. Draw down the Cable Clamp evenly and tighten nuts to 65 ft-lbf [88 N m].

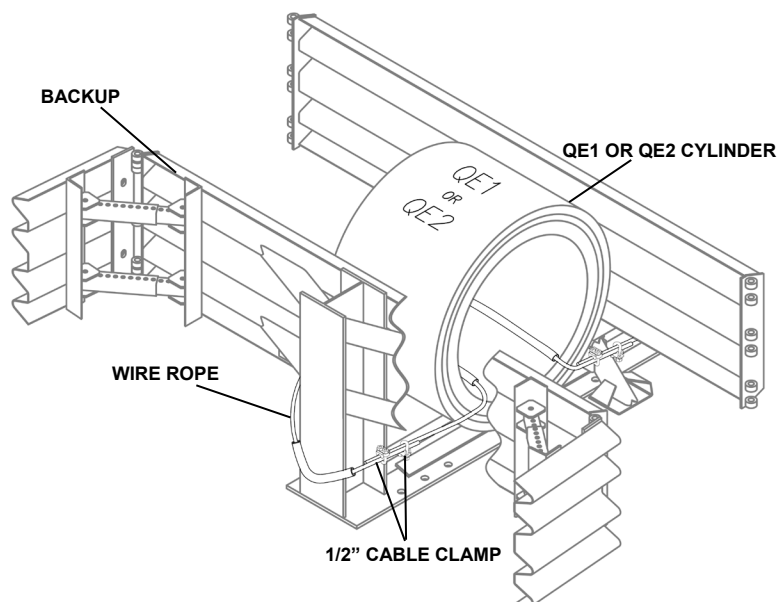

Figure 52
Cylinder Assembly

9) Attach the Remaining Cylinders

Continue attaching the Cylinders to their common diaphragms using the 1/2" cable, Cable Clamps, and Cable Jacketing Tube (Figures 53 – 57).

Work forward from the Backup assembling Cylinders as you proceed forward.

Be sure to remove any clearance between the Cylinders and their adjacent Diaphragms prior to removing all possible cable slack before tightening the Cable Clamps.

Except where otherwise noted, the Cable Jacketing Tube should be centered within the length of the Cylinders as shown to prevent the cable from damaging the Cylinders. Figures 53 – 57 illustrate Cylinder configuration at each Diaphragm location.

10) Attach the QE1 Cylinders

Assemble the QE1 Cylinders in the appropriate Bays towards the front of the system in the same manner used to assemble the QE2 Cylinders.

Again, it is important that all clearance be removed between the QE1 Cylinders and their adjacent Diaphragms before tightening cable.

There is no Cylinder in Bays 1 and 2, therefore, the 1/2" diameter cable just wraps around the legs on the front of the 3rd Diaphragm as shown in Figure 57.

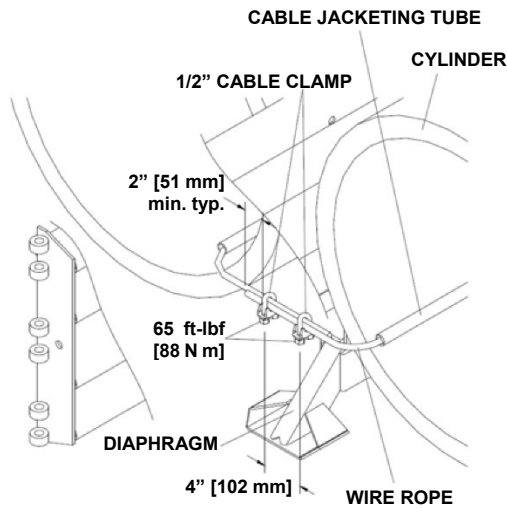

Figure 53

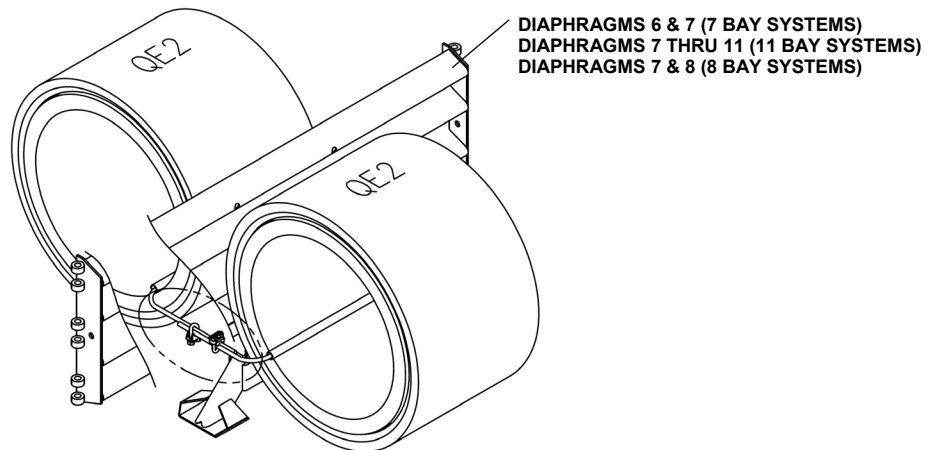

Figure 54

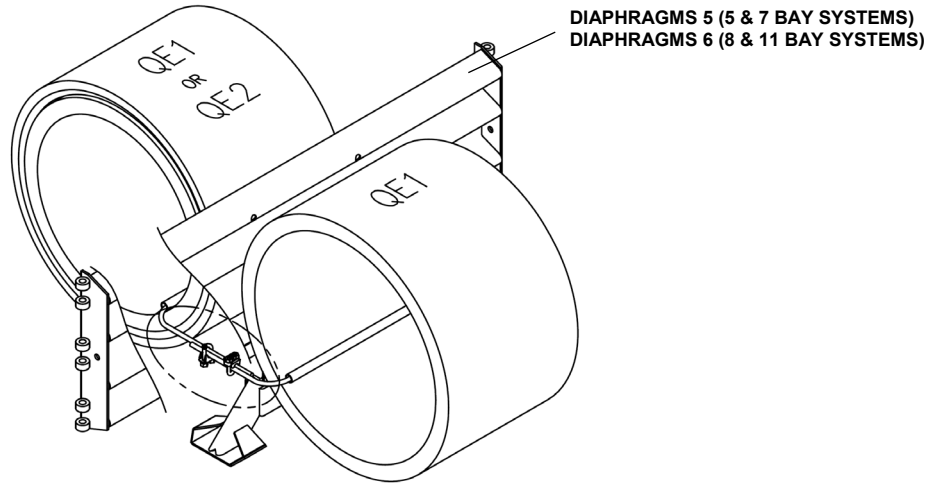

Figure 55

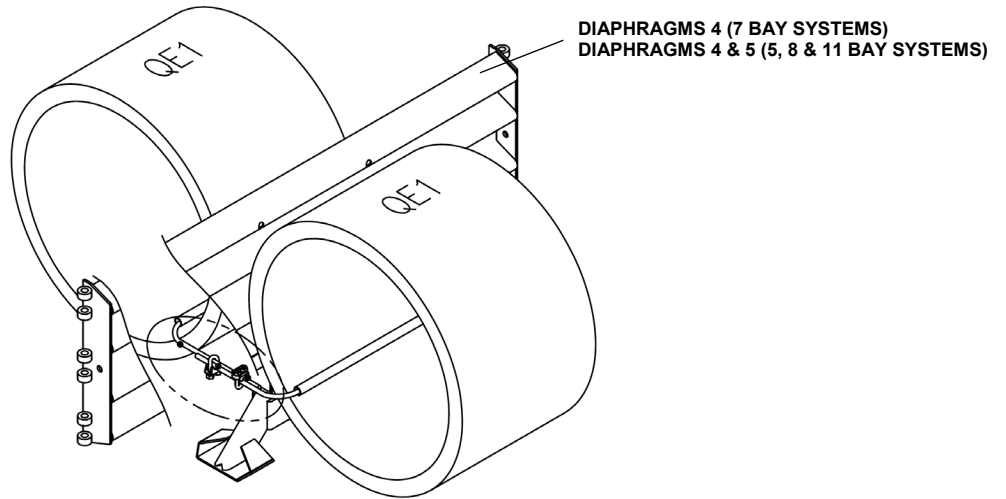

Figure 56

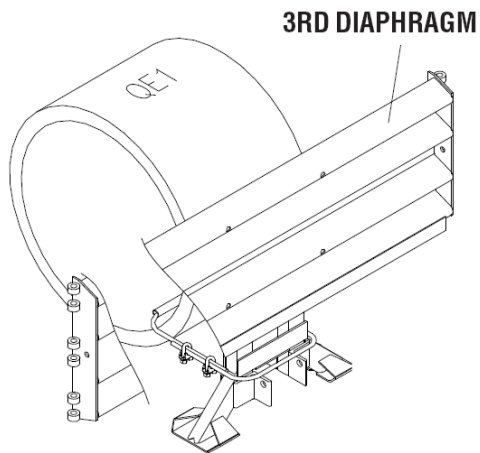

Figure 57
QE1 Cylinder Mounting to 3rd Diaphragm

11) Attach Indexing Chains

Use two (2) Indexing Chains between each Bay from Bay 3 to Backup. Attach Indexing Chains using 1/2" diameter x 2" long hex head bolts, nuts, and washers as shown in Figure 58.

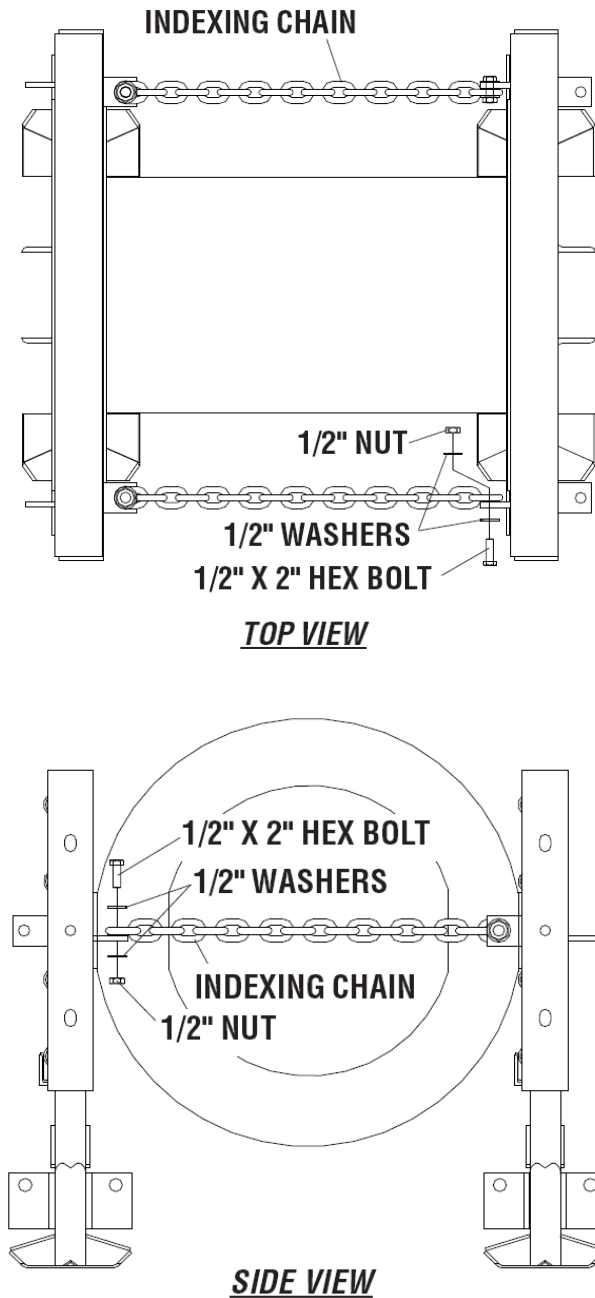

Figure 58
Attach Indexing Chains
(Fender Panels not shown for clarity)

12) Attach End Cap

Using 5/8" x 3 1/2" G5 hex bolt, 5/8" hex nut, and 5/8" lock washer, attach the end cap to the front of the first Monorail segment (Figure 59).

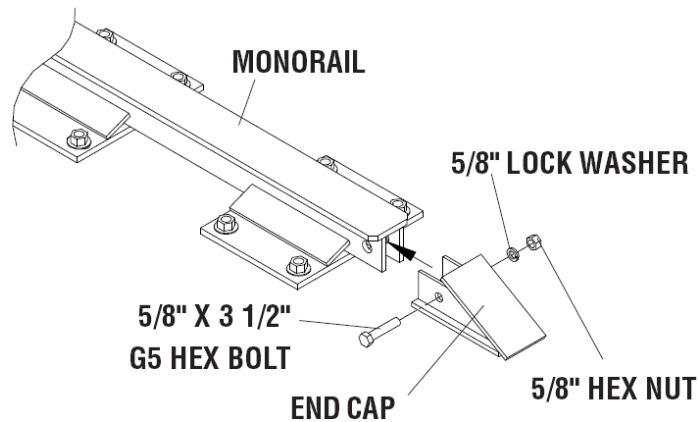

Figure 59
End Cap Attachment

13) Attach Fender Panel(s)

Note: Hinge plates may be factory assembled to Diaphragms. If not, use 5/8" x 4" hex bolts, lock washers, and nuts as hinge pins to attach Hinge Plates to Diaphragm.

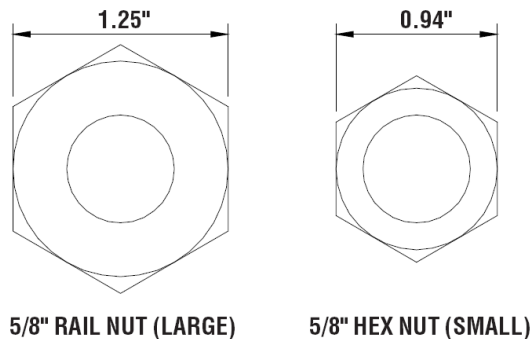

Figure 60
Rail Nuts are Oversized



Important: Do not mix the 5/8" rail nuts (large) with the 5/8" hex nuts (small). The rail nuts are oversized.

- Starting at the last Bay, attach left and right Fender Panels as shown in Figure 61. Attach the hinge plate at the front of the Fender Panels to the Diaphragm in front using three (3) 5/8" x 4" hex bolts, 5/8" hex nuts, and 5/8" lock washers.
- Attach Mushroom Washer Assembly as shown in Figures 61 & 62 but do not tighten at this time.
- Be sure Mushroom Washer lays flat against the Fender Panel as shown in Figure 62. Standoff on washer must be seated completely through slot.

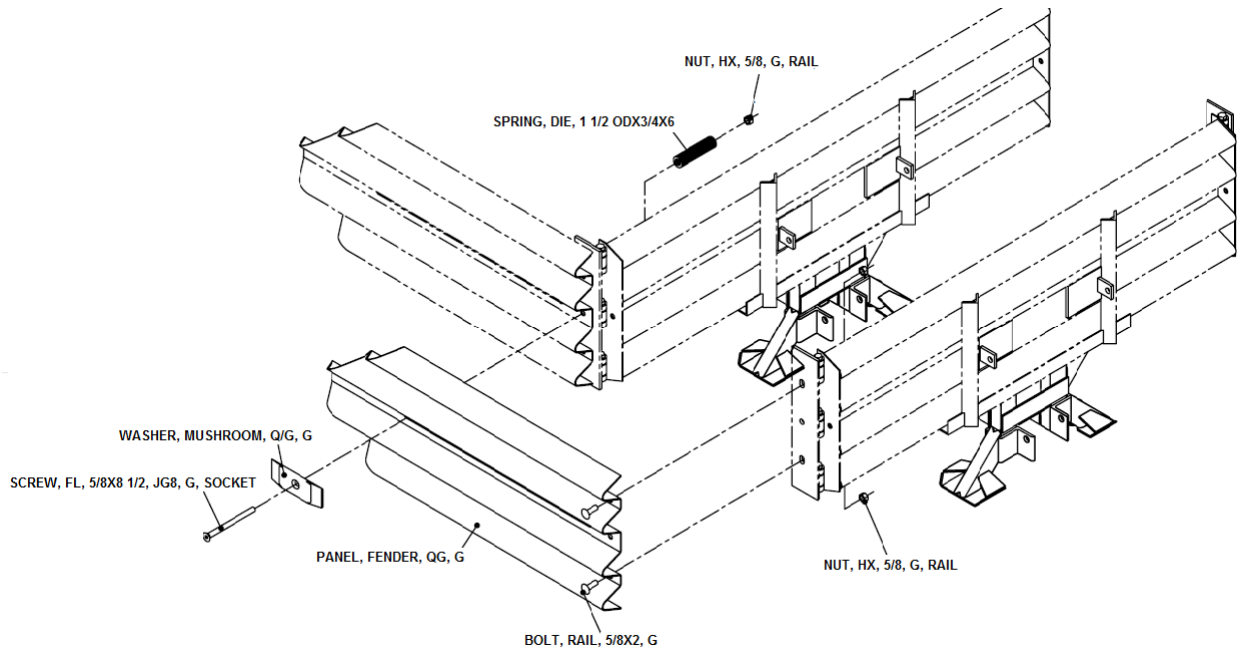

Figure 61
Fender Panel Assembly

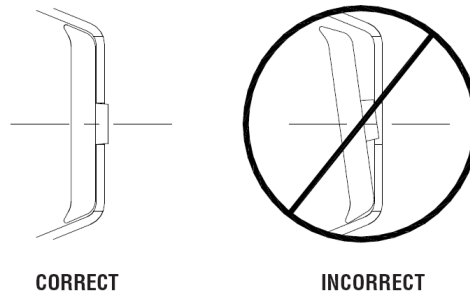

Figure 62
Mushroom Washer Orientation

14) Attach Pullout Brackets

Using 5/8" X 2 1/4" G8 hex bolts, 5/8" x 1 3/4" flat washers, and 5/8" hex nuts, attach Pullout Brackets to 1st Diaphragm as shown in Figure 63.

Be sure Mushroom Washer lays flat against the Fender Panel as shown in Figure 62. Standoff on washer must be seated completely through slot.

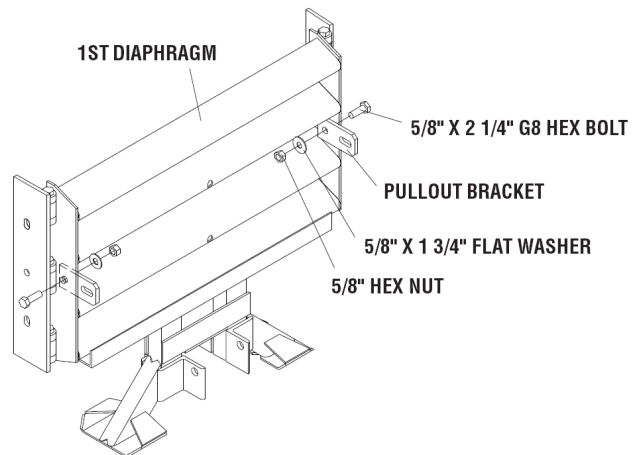

Figure 63
Pullout Bracket Attachment

15) Attach Nose Cylinder

Attach the Nose Cylinder using two (2) 1/2" x 5 3/4" long threaded rods through the Nose Cylinder Plate, Nose Cylinder, and Diaphragm (Figure 64). Secure each 1/2" threaded rod with flat washers, nuts, and a Nose Clamp Shim. Torque threaded rods to a 20 ft-lbf [27 N m] minimum and 60 ft-lbf [80 N m] maximum.



Warning: Placing the wrong type Cylinder in the Nose or any Bay **will** result in unacceptable crash performance as described in NCHRP Report 350.

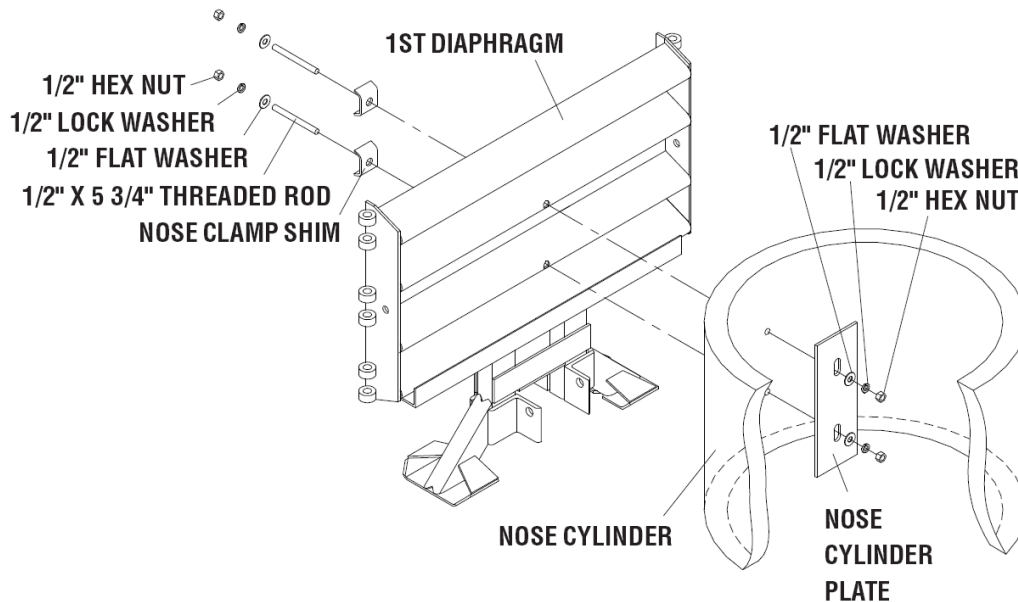

Figure 64
Attach Nose Cylinder to First Diaphragm

16) Attach Belt Nose

- Using 5/8" x 5" hex bolts, 5/8" x 1 3/4" flat washers, and 5/8" hex nuts, attach hinge plate to Fender Panel as shown in Figure 66 (three places per side).
- Thread second 5/8" nuts onto the assembled bolts. Be sure the faces of the nuts are flush with humps on Fender Panels (Figure 66). Slide second 5/8" x 1 3/4" flat washers onto bolts (three places per side).
- Align holes in each end of the Nose Belt with the assembled bolts (three per side) and slide Nose Belt onto bolts.
- Align holes in Belt Clamps with bolts and slide Belt Clamps onto bolts.

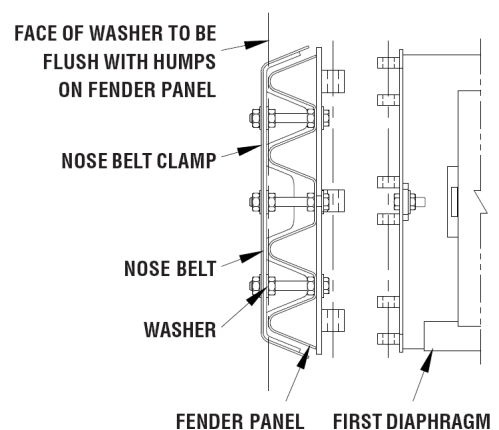

Figure 65

- e. Using third 5/8" x 1 3/4" flat washers and third 5/8" hex nuts, secure the Belt Clamps and Nose Belt (three places per side).
- f. Be sure Fender Panel assembly is bolted to Diaphragm at the hinge plate with 5/8" x 5" hex bolts, 5/8" nuts, and 5/8" flat washers in 3 places on each side.

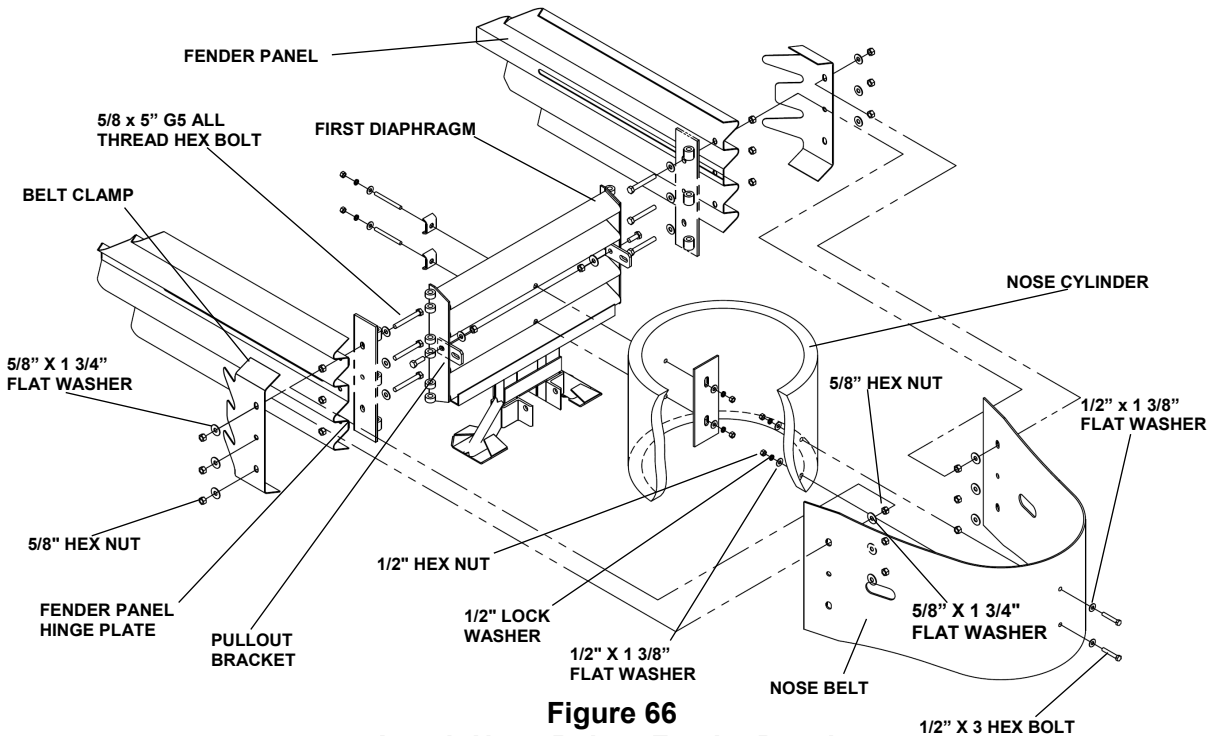

Figure 66
Attach Nose Belt to Fender Panels

Note: The Nose of the system may be delineated to comply with local codes (inverted chevron, reflectorized sign, etc.).

17) Diaphragm Spacing

Attach 3/8" [10 mm] grade 40 x 20' [6 m] chain to Pullout Brackets on Diaphragm No. 1 (Figure 66). Attach both ends of chain to a heavy vehicle (such as a 1 ton pickup truck).

Pull the QuadGuard® Elite forward slowly until the system is fully extended, chains are taut, and Mushroom Bolts are bottomed out in slots in Diaphragms without chains.

Torque all Mushroom Washer Assembly nuts until they bottom out on threads of screws. Remove chains from Pullout Brackets.



Warning: Stand clear in case chain breaks or becomes disconnected.

Note: Do not wrap a chain around the bottom legs of the front Diaphragm and pull. This may cause binding of the system. The pull force should be aligned with the long slots in the Fender Panels to prevent system binding.

18) Assemble Hit Indicator to Diaphragm No. 1

The Hit Indicator should be the last component attached to the system. Bolt the Hit Indicator to the first Diaphragm with the hardware provided as shown in Figure 67.

Rotate the Hit Indicator to its horizontal position and lock it into position by bending the Trigger Clip around the second Diaphragm as shown in Figure 68.

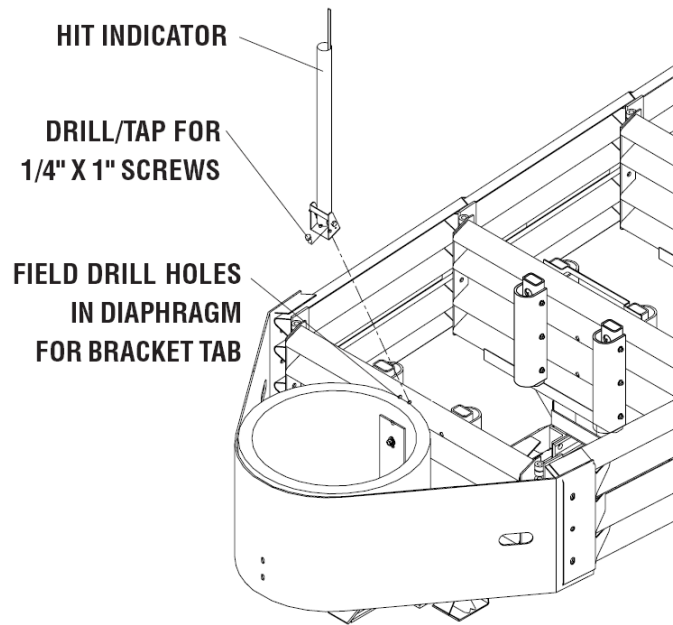

Figure 67
Attach Hit Indicator

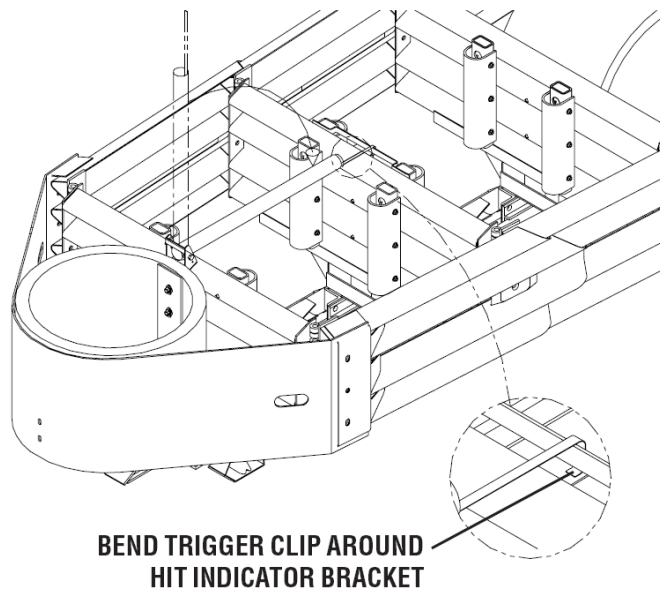

Figure 68
Rotate Hit Indicator/Bend Trigger Clip

19) Checking the System Assembly

Check to ensure that all fasteners are properly tightened throughout the system at this point (anchor bolts, etc.). Check all Fender Panels per table below. If they do not fit tightly against the underlying panel, system realignment may be necessary (Figure 69).



Caution: Ensure QuadGuard® Elite installation and delineation meet all appropriate Manual on Uniform Traffic Control Devices (“MUTCD”), federal, state, specifying agency, and local specifications.



Warning	
Mushroom Bolt Assemblies	Torqued to 60 ft-lbf [80 N·m]
Anchor Studs	Torque to manufacture specification Studs shall NOT Protrude Above Nuts (Figure 46 on p. 41).
All Other Bolts	Tightened
Parallel Systems Flared Systems See below	Maximum Gap Allowed .78” [20 mm] 1.00” [25 mm] Figure 69
Cable Clamps	Torque to 65 ft-lbf [84 N·m]

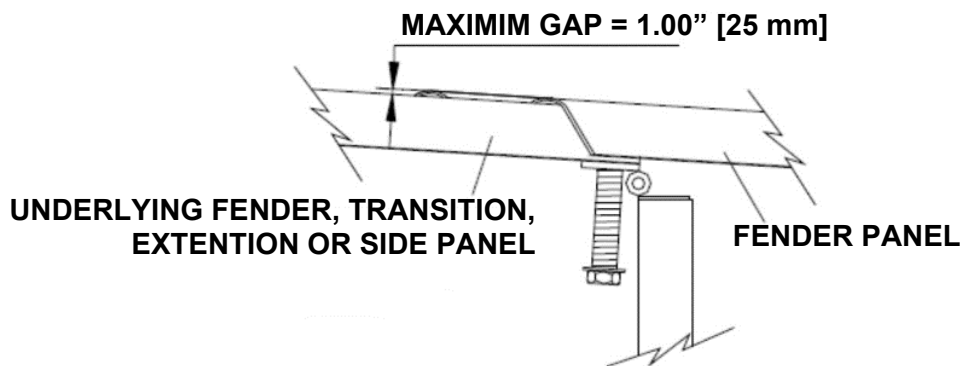

Figure 69
Maximum Fender Panel Gap on Bidirectional Traffic Side of System

20) Inspect System

Inspect the system in accordance with the QuadGuard® Elite Maintenance Flow Chart (p. 61).

Maintenance



Important: Visual Drive-By Inspections are recommended at least once a month. Walk-Up Inspections are recommended, as needed, based upon volume of traffic and impact history.

Visual Drive-By Inspection

- 1) Encountering a system with the Hit Indicator in the vertical position mandates a walk-up inspection of the system.
- 2) Inspect the system in accordance with the QuadGuard® Elite Maintenance Flow Chart on page 61.



Caution: It is important to inspect a system after an impact even if it appears to be self-restored and fully maintained. In particular, check the Fender Panels/Diaphragm attachment bolts to ensure none have failed. Again, only the local highway authority can determine if the system is reusable after impact.

Note: Refer to Cylinder placement on pages 59 and 60.

- 3) Be sure the Nose Cover is in place.
- 4) Maintain a log of the location and condition of the QuadGuard® Elite to record the date of each visual drive-by inspection (p. 63).

Walk-Up Inspection



Caution: A system that has been impacted can store energy in collapsed Cylinders and may spring back unexpectedly causing serious injury (p. 57). Use caution when inspecting, disassembling or restoring systems that are collapsed in any way.

Maintenance Checklist

- 1) Clear and dispose of any debris on site.
- 2) Inspect all bolts for signs of rust and a snug fit.
- 3) Ensure all Concrete Anchor Bolts are securely anchored.
- 4) Diaphragm Legs are straight and chains are taut.
- 5) Mushroom Washer Assemblies are properly aligned and positioned (Figure 71).
- 6) Fender Panels and Transition Panels should nest tightly against the system. For wrong way traffic, the maximum gap allowed is .78" [20 mm] for narrow systems and 1.00" [25 mm] for wide systems (p. 57).
- 7) Check all Cylinders to ensure good condition and proper position on Support Brackets.



Important: The energy-absorbing plastic Cylinders lose their ability to absorb energy from cumulative impacts. After multiple full capacity design impacts, the system will no longer be able to meet the requirements as specified in NCHRP Report 350. To ensure Cylinder replacement is accomplished before this occurs; it is essential that an inspection of the Cylinders be conducted every time the Hit Indicator signals an impact. It is the sole discretion of the local highway authority that has specified the use of this system as to whether the system or any part thereof continues in use.

The rear-most Cylinder must measure at least 26" [660 mm] for proper impact performance (Figure 70). If distance is less than 26" [660 mm], replace all QE1, QE2 and QEN Cylinders. If distance is greater than 26" [660 mm], inspect all Cylinders for major cracks, tears or cuts. Replace any damaged Cylinders. Please contact the Valtir Customer Service Department if you have any questions (p. 3).

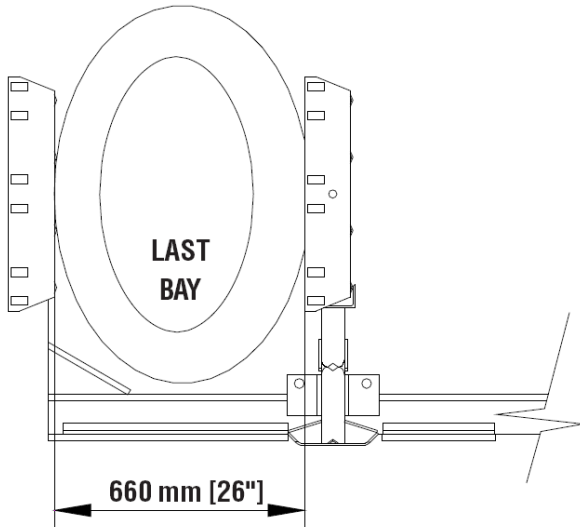

Figure 70
Distance Across Minor Axis of QE2 Cylinder

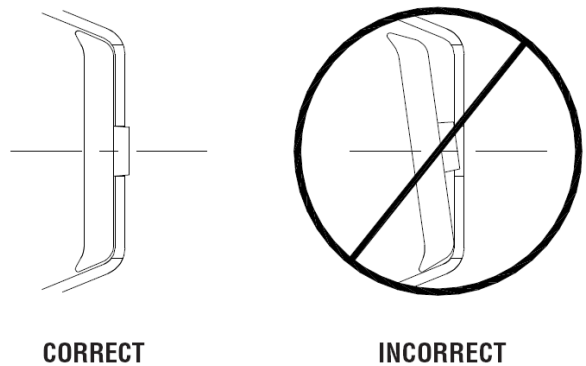

Figure 71
Mushroom Washer Orientation

Note: Refer to Cylinder placement on pages 59 and 60.

- 8) Be sure system is at its full length.



Warning: Systems that are not restored to their full length **will not** perform to impact performance standards of NCHRP Report 350.

- 9) Make all necessary repairs as described above and see Post-Impact Instructions for more information (p. 54).
- 10) Note the location and condition of the QuadGuard® Elite, and any work done, in the **Attenuator Inspection Logbook** under each inspection date (p. 63). If further repair is required, make a repair request date entry.

Post-Impact

- 1) Deploy the appropriate traffic-control devices to protect your crew. Follow the local codes and traffic control plan as set forth by the local highway authority.
- 2) **Follow all instructions on page 57 to restore the collapsed system before step 3.**



Warning: A system that has been impacted can store energy in collapsed Cylinders and **may spring back unexpectedly** causing serious injury. Use caution when disassembling and refurbishing damaged units.

- 3) Check to see that all Anchor Bolts have remained firmly anchored to the roadway surface. Replace any that are loose, broken, or pulled out. System performance depends on proper deployment of the Monorail Anchors (p. 57).
- 4) Clear and dispose of any debris on the site.
- 5) Check each Fender Panel and Mushroom Washer Assembly to ensure both have not been deformed in any way to prevent pulling the system back to its ready position.
- 6) Be sure that the Diaphragm Support Legs are all properly attached to the Monorail.
- 7) Attach 3/8" [10 mm] x 20' [6 m] Grade 40 chain to Pullout Brackets on first Diaphragm (Figure 72). Attach both ends of chain to a heavy vehicle (such as a 1 ton pickup).



Warning: Stand clear when pulling system out in case chain breaks or becomes disconnected.

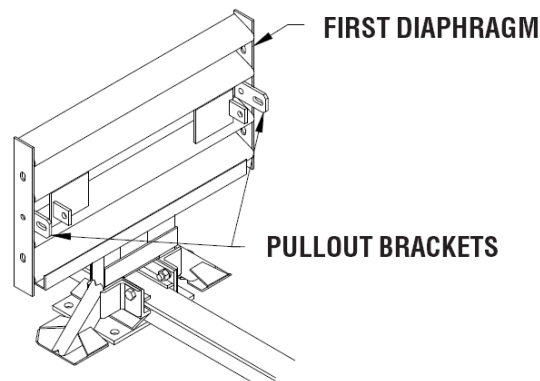

Figure 72
Attach Chain to Pullout Brackets



Important: Do not wrap a chain around the bottom legs of the front Diaphragm and pull as this may cause the system to bind. The pull force should be aligned with the long slots in the Fender Panels to ensure a smoother system extension.



Important: Slowly pull the QuadGuard® Elite forward until the system reaches its original length. Have someone watch the system during repositioning to be certain previously undetected damage does not cause the Diaphragms to bind or pull out improperly.



Important: Valtir makes no recommendation whether use or reuse of any part of the system is appropriate or acceptable following an impact. It is the sole responsibility of the local highway authority and its engineers to make that determination. It is critical that you inspect this product after assembly is complete to make certain that the instructions provided in this manual have been strictly followed.

- 8) Remove all damaged Cylinders from within the system. Inspect the system in accordance with the QuadGuard® Elite Maintenance Flow chart on page 61. The Cylinders are potentially reusable after typical design speed impacts (p. 6).
- 9) Check to see that the Diaphragms are in usable condition. Diaphragms that are bowed or have bent legs must be replaced.
- 10) Check that the Fender Panels are properly attached with the Mushroom Washer Assemblies. Check all bolt connections of Fender Panels to Diaphragms. Damaged bolts, Fender Panels, and Transition Panels must be replaced.
- 11) Check the gap of the Fender Panels. The maximum gap allowed for these overlapping parts on the side of the system with traffic approaching from the rear (including Fender Panels overlapping components behind the system) is .78" [20 mm] for narrow systems and 1.00" [25 mm] for wide systems (Figure 73). Ensure Mushroom Washer Assemblies are torqued to 60 ft-lbf [80 N m]. If the gaps between the Fender Panels are still too large, it may be necessary to replace bent parts.
- 12) Replace all damaged Cylinders. Inspect the system in accordance with the QuadGuard® Elite Maintenance Flow Chart (p. 61). If a Cylinder's condition is questionable, a photo of the Cylinder may be forwarded to Valtir for evaluation.
- 13) Check the torque of all fasteners on the system (p. 56).
- 14) Check that the site is free from any debris. The QuadGuard® Elite is now ready for use.

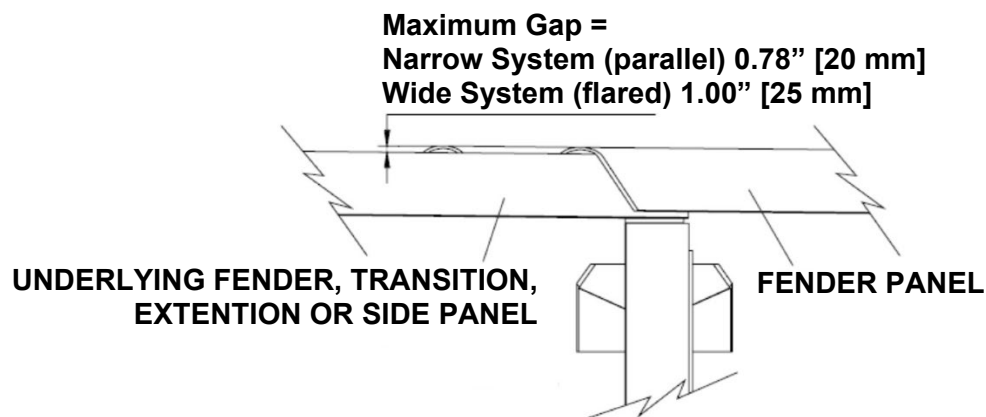

**Figure 73
Fender Panel Gap**



Warning	
Mushroom Bolt Assemblies	Torqued to 60 ft-lbf [80 N·m]
Anchor Studs	Torque to manufacture specification. Studs should NOT protrude above nuts (Figure 74).
All Other Bolts	Tightened

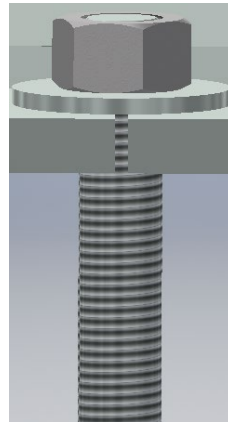

Figure 74
Anchor Application
(Before Applied Torque)

Note: Push the stud, nut, and washer assembly down through the part and into the borehole until the washer is seated against the part (Figure 74).



Warning: Do not disturb or load the stud until the approved adhesive material has fully cured per manufacturer specifications.



Warning: Self-restoring systems, such as the QuadGuard® Elite, have the ability to store energy that could cause sudden system movement and injury to maintenance workers. After impacts that exceed the NCHRP Report 350 criteria, a system may bind and store energy. This condition would be visually evident by Bays of the system staying collapsed after an impact (with Bay-spacing of 24" or less for the QuadGuard® Elite). Extreme compression of QuadGuard® Elite cylinders after an impact, especially the thick-walled cylinder (QE2), is an indication that the system is storing large amounts of energy. Every compressed QuadGuard® Elite repair must be done with caution.



Warning: DO NOT stand in front, on top, or put any portion of your body on or inside any part of a collapsed system. Instead, use a chain and truck to pull from the front of the system as explained on the next page.

Restore Collapsed System

Before starting this procedure, please read and understand the previous “**Warning**” statements (p. 56). The following instructions outline a set of steps for positioning a large vehicle up against a compressed system to prevent unexpected system movement while maintenance workers are attempting to repair the system.

- A) Position a truck of not less than 13,250 lbs. [6000 kg] centered on the system just in front of the Nose Assembly. The truck should be presenting its strongest bumper to the system. The selected bumper’s height should be such that the center of the bumper rests on the middle of the system’s Nose Assembly (approximately, 24” [610 mm] in height).
- B) Drive the truck so that the bumper displaces the systems Nose Cylinder approximately 6” [150 mm]. In the absence of the Nose Assembly, place a protective material between the bumper and the leading Diaphragm leaving approximately 1.00” [25 mm] gap between the protective material and the vehicle’s bumper. The driver should remain in the vehicle depressing the brake pedal after the vehicle has been placed in position.



Warning: Once the leading bumper is over the system’s Monorail, the vehicle may be subject to impact by the system due to an unexpected restoration. The driver should be wearing a seat belt and have the vehicle in the lowest possible gear when approaching the system. In the event that the system unexpectedly deploys before Step B is completed, the driver should apply the brakes immediately, bringing the vehicle to a controlled stop. The driver should then put the vehicle in neutral while still applying the brakes. Gradually release the brakes, allowing the system to push the vehicle back in a safe and controlled manner.

- C) It should now be safe for a maintenance worker to inspect the system to determine where mechanical binding is present. Remove all debris from the system prior to checking for binding. The binding will probably be located at the monorail guides on the forward-most Diaphragm(s) or Fender Panels. Cautiously using a pry bar or jostling the system with a vehicle may aid in releasing the binding mechanism. Once released, the driver should allow the system to extend in a safe and controlled manner.



Warning: Use caution when releasing any binding mechanism. Keep hands and other body parts clear of possible system interaction. Be aware of tools (pry bar, etc.) that could move unexpectedly if a bind is suddenly released.

- D) Replace all damaged system components and reassemble per the QuadGuard® Elite Manual Assembly instructions.

Parts Ordering Procedure

Make a list of all damaged parts using part descriptions shown on pages 59 and 60. Answer the following questions in the spaces provided. This information is necessary to receive the proper parts.

Description:	Choices	Fill in this section
What type of Transition Panel? Be sure to note right side, left side, or no Transition (p. 15).	Quad to W Beam Quad to Thrie Beam Quad to End Shoe Quad to Safety Shape Barrier	
Width of Backup	4" [100 mm] Offset Panel 24" [610 mm] 30" [760 mm] 36" [915 mm] 64" [1620 mm] 83" [2100 mm] Other	



Warning: Use only Valtir parts that are specified herein for assembling, maintaining, or repairing the QuadGuard® Elite. **Do not utilize or otherwise comingle parts from other systems even if those systems are other Valtir systems.** Such configurations have not been tested, nor are they eligible for use. Assembly, maintenance, or repairs using unspecified parts or accessories is strictly prohibited.



Warning: DO NOT modify the QuadGuard® Elite in any way.

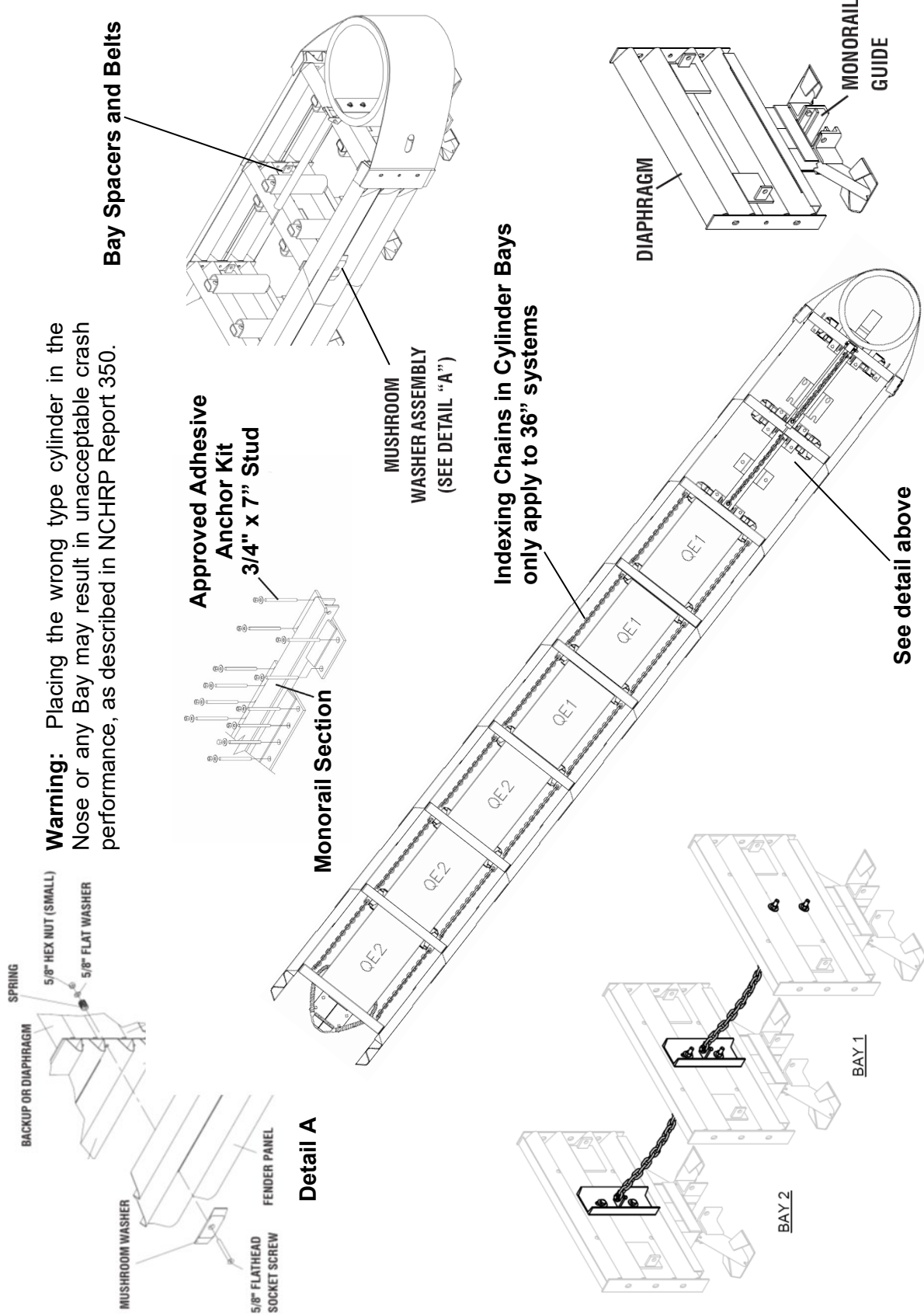

Warning: Placing the wrong type cylinder in the Nose or any Bay may result in unacceptable crash performance, as described in NCHRP Report 350.

Bay Spacers and Belts

Approved Adhesive Anchor Kit
3/4" x 7" Stud

Detail A

Indexing Chains in Cylinder Bays
only apply to 36" systems

See detail above

Detail of indexing chains for 24", 30" and 36" system

Figure 75

Warning: Placing the wrong type cylinder in the Nose or any Bay may result in unacceptable crash performance, as described in NCHRP Report 350.

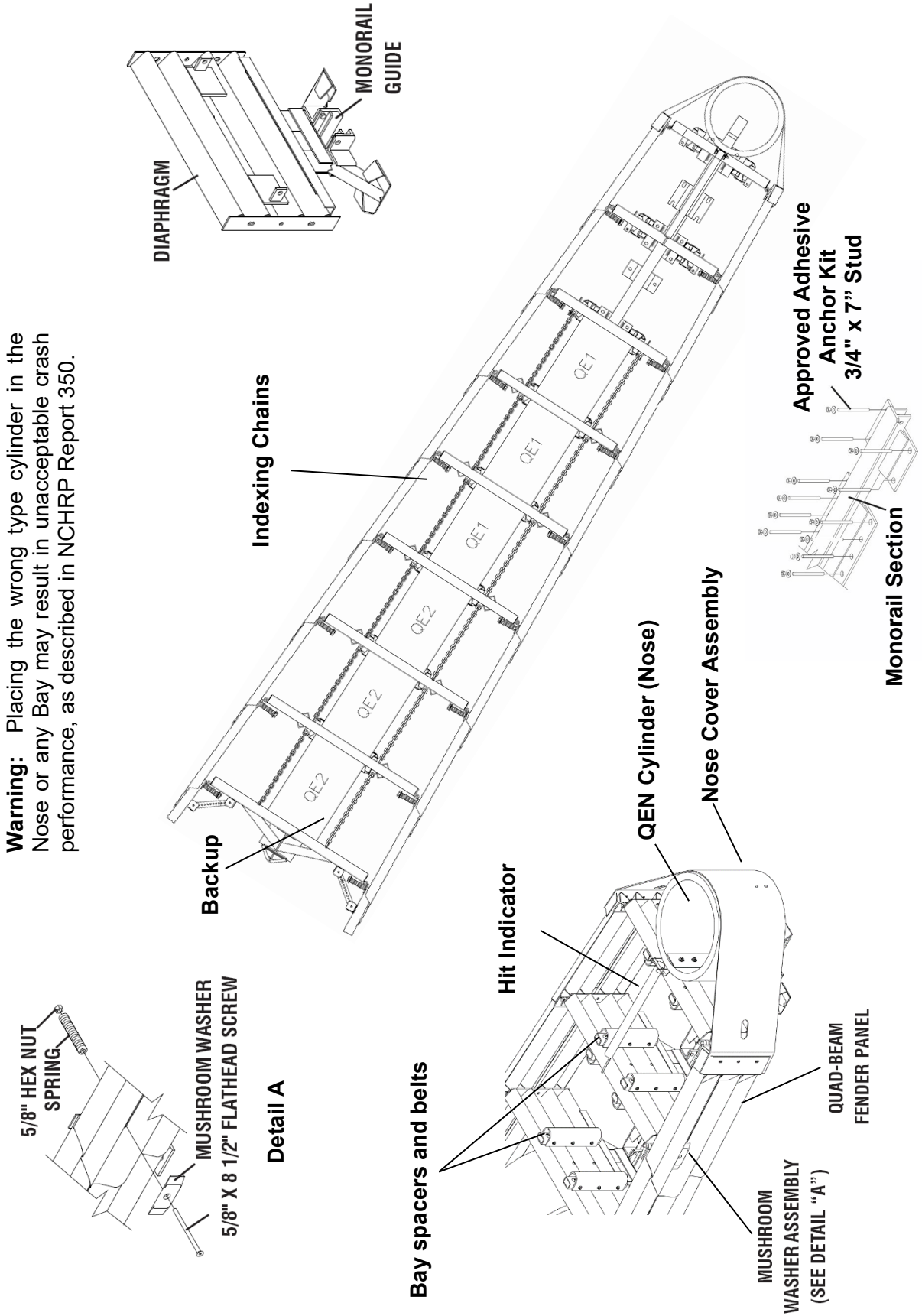
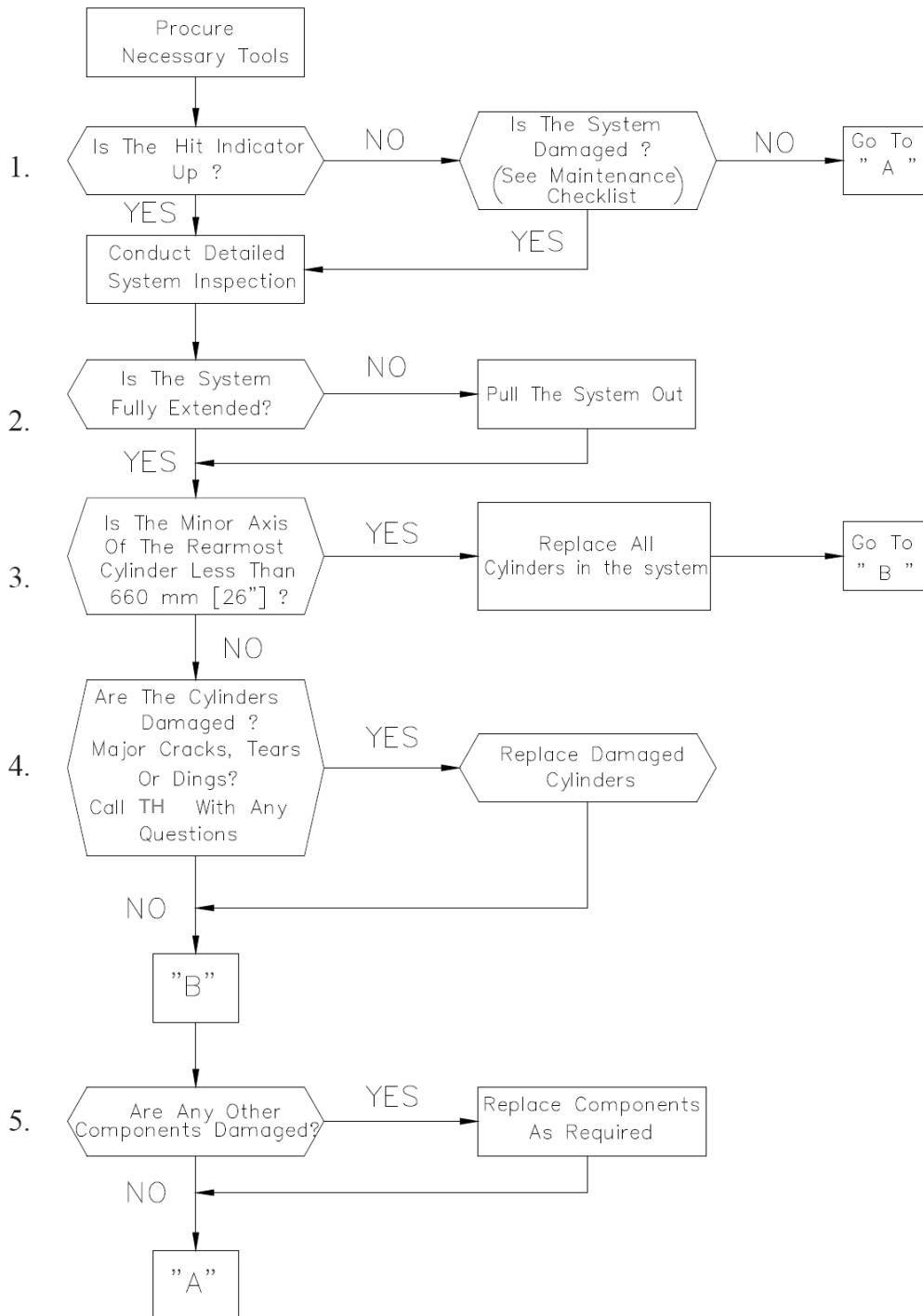

Figure 76

Maintenance Flow Chart

This flow chart is provided only to clarify the sequence of steps. Refer to the appropriate sections of this manual for any procedures that need to be performed.



QuadGuard® Elite Maintenance Flow Chart

Final Inspection Checklist

Site Location: _____

Date: _____

Inspector: _____

Refer to the QuadGuard® Elite Assembly manual and/or drawing package.

- Anchor nuts are torqued to adhesive manufacturer specification (p. 8)
- Minimum clearance of 25" behind rear Fender Panels for movement (p. 14)
- Proper Transition Panel is used for the type of barrier (pp. 15 – 16 & 35 - 36)
- If no transition is used, narrow side panels are used with backup (pp. 15 & 35)
- Every borehole and slot in Backup and Monorail is utilized (pp. 19 & 38)
- Monorail guides are attached to the Diaphragms with shims (pp. 20 & 40)
- Monorail End Cap Assembly in place (pp. 26 & 46)
- Mushroom Washers tabs lay flat within Fender Panel slots (p. 27 & 47)
- Fender Panel gap is 0.78" or less for parallel systems (pp. 32, 33, 51, 55)
- Fender Panel gap is 1" or less for flared systems (pp. 32, 51, 55)
- Bolts and nuts are properly tightened throughout the system (pp. 32, 51)
- Anchor stud(s) height is 1.5" or less above the pad (p. 39)
- Fender Panel nuts are bottomed out on Mushroom Washer bolt (p. 47)
- Cylinder types are in properly placed and have cables attached (pp. 59, 60)
- Chains are in all Bays except Bay 1 & 2 (48" unit has chains in Bay 1 & 2) (pp. 59, 60)
- System is clear of debris



Important: It is critical that you inspect this product after assembly is complete to make certain that the instructions provided in this manual have been strictly followed.

Valtir QuadGuard® Elite

Inspection Logbook

Supervisor: _____

Location: _____

Position: _____

Condition: _____

Repair(s): _____

Date: _____

Additional Repair Request: _____

Repair Request Date: _____

Notes:

Notes:

Notes:



For more complete information on Valtir products and services, visit us on the web at www.valtir.com. Materials and specifications are subject to change without notice. Please contact Valtir to confirm that you are referring to the most current instructions.

WWW.VALTIR.COM
1.888.323.6374

