



QUEST[®]

TL-2 & TL-3 CRASH CUSHION

ASSEMBLY MANUAL



PN 115249
REVISION D DECEMBER 2022

QUEST®

TL-2 & TL-3

The QUEST® has been tested pursuant to National Cooperative Highway Research Program (“NCHRP”) Report 350 specifications. The QUEST® has been deemed eligible for federal-aid reimbursement by the Federal Highway Administration (“FHWA”).

Assembly Manual



15601 Dallas Parkway
Suite 525
Addison, Texas 75001



Warning: The local highway authority, distributors, owners, contractors, lessors, and lessees are **RESPONSIBLE** for the assembly, maintenance, and repair of the QUEST®. Failure to fulfill these **RESPONSIBILITIES** with respect to the assembly, maintenance, and repair of the QUEST® could result in serious injury or death.



Important: These instructions are for standard assembly specified by the appropriate highway authority. In the event the specified system assembly, maintenance, or repair would require a deviation from standard assembly parameters, contact a Valtir representative. This system has been deemed eligible by the FHWA for use on the national highway system under strict criteria utilized by that agency.

This manual must be available to the worker overseeing and/or assembling the product at all times. For additional copies, contact Valtir at (888) 356-2363 or download from Valtir.com.

The instructions contained in this manual supersede all previous information and manuals. All information, illustrations, and specifications in this manual are based on the latest QUEST® information available to Valtir at the time of printing. We reserve the right to make changes at any time. Please contact Valtir to confirm that you are referring to the most current instructions.

QUEST® is a registered trademark of Valtir, LLC.

Part No. 115249

© Valtir, LLC

Valtir.com

1

Revision D December 2022

Table of Contents

Customer Service Contacts	3
Important Introductory Notes.....	3
Safety Symbols	4
Safety Rules for Assembly.....	4
Limitations and Warnings.....	5
QUEST® Model Numbers.....	5
System Overview	6
Selection Criteria	7
Special Site Conditions	7
Site Preparation Foundation	8
Valtir Approved Adhesive Anchoring System	9
Vertical Assemblies.....	9
Anchor Assembly Cautions.....	10
Horizontal Assemblies.....	11
Parts Identification.....	15
Pictorial Assembly.....	24
Recommended Tools.....	46
Assembly Procedures	48
Bidirectional Traffic.....	52
Transition and Side Panel Types	53
Maintenance Checklist.....	54
Visual Drive-By Inspection	54
Walk-Up Inspection	54
Post Impact Instructions.....	55
Repair Procedure	55
Parts Ordering Procedure	55

Customer Service Contacts

Valtir is committed to the highest level of customer service. Feedback regarding the QUEST®, its assembly procedures, supporting documentation, and performance are always welcome. Additional information can be obtained by calling the telephone numbers below:

Valtir:

Telephone:	(888) 356-2363 (USA) +1 214 589-8140 (International)
Website:	Valtir.com

Important Introductory Notes

Proper assembly of the QUEST® is critical to achieve performance that has been evaluated and accepted by the FHWA per NCHRP Report 350. These instructions should be read in their entirety and understood before assembling the QUEST®. These instructions are to be used only in conjunction with the assembly of the QUEST® and are for standard assemblies only as specified by the applicable highway authority. If you need additional information, or have questions about the QUEST®, please contact the highway authority that has planned and specified this assembly and, if needed, contact Valtir's Customer Service Department. This product must be assembled in the location specified by the appropriate highway authority. If there are deviations, alterations, or departures from the assembly protocol specified in this manual, the device may not perform as it was tested and accepted.



Important: DO NOT use any component part that has not been specifically specified herein for the QUEST® during assembly or repair of this system.

This product has been specified for use by the appropriate highway authority and has been provided to that user who has unique knowledge of how this system is to be assembled. No person should be permitted to assist in the assembly, maintenance, or repair of this system that does not possess the unique knowledge described herein. These instructions are intended for an individual who is qualified to both read and accurately interpret them as written. These instructions are intended only for an individual experienced and skilled in the assembly of highway products that are specified and selected by the highway authority.

A manufacturer's drawing package will be supplied by Valtir upon request. Each system will be supplied with a specific drawing package unique to that system. Such drawings take precedence over information in this manual and shall be studied thoroughly by a qualified individual who is skilled in interpreting them before the start of any product assembly.

Safety Symbols

This section describes the safety symbols that appear in this QUEST® manual. Read the manual for complete safety and assembly information.

Symbol

Meaning



Safety Alert Symbol: Indicates Danger, Warning, Caution, or Important. Failure to read and follow the Danger, Warning, Caution, or Important indicators could result in serious injury or death to the workers and/or bystanders.



Important: Read safety instructions thoroughly and follow the assembly directions and suggested safe practices before assembling, maintaining, or repairing the QUEST®.



Important: Please keep up-to-date instructions for later use and reference by anyone involved in the assembly of the product.

Safety Rules for Assembly

*** Important Safety Instructions ***

This manual must be kept in a location where it is readily available to persons who assemble, maintain, or repair the QUEST®. Additional copies of this manual are available from Valtir by calling (888) 356-2363 or by visiting Valtir.com. Please contact Valtir if you have any questions concerning the information in this manual or about the QUEST®.

Always use appropriate safety precautions when operating power equipment, moving heavy equipment and QUEST® components. Safety articles including but not necessarily limited to work gloves, eye protection, safety-toe shoes and back support should be used.



Warning: It is the responsibility of the installer to use all safety measures incorporating appropriate traffic control devices specified by the highway authority. These measures must be used to protect all personnel while at the assembly, maintenance, or repair site.



Warning: Failure to comply with these warnings could result in increased risk of serious injury or death in the event of a vehicle impact with a system that has not been accepted by the FHWA.



Warning: Use only Valtir parts on the QUEST® for assembly, maintenance, or repair. **The assembly or comingling of unauthorized parts is strictly PROHIBITED.** The QUEST® and its component parts have been accepted for state use by the FHWA. However, a comingled system has not been accepted within the applicable criteria.

Limitations and Warnings

The QUEST® has been shown to decelerate and stop light and heavy-weight vehicles (1804 to 4400 lb. [820 to 2000 kg]) when impacted head-on at angles up to 15° on the nose at 44 mph [70 kph], 62 mph [100 kph] and 71 mph [115 kph] respectively; and to redirect heavy-weight vehicles (2000 kg [4400 lb.]) when impacting at 44 mph [70 kph] and 62 mph [100 kph] respectively along the system's side at 20° or less. Tests were conducted on asphalt and concrete with slopes less than 8° and without curbs.

During head-on impacts, if impacted within NCHRP Report 350 criteria, the QUEST® has been shown to telescope rearward and energy is absorbed through momentum transfer, friction and deformation. When impacted from the side, within the same criteria, the QUEST® has been shown to restrain lateral movement by dynamic tension developed between end restraints to safely redirect the impacting vehicle.



Warning: Do NOT modify the QUEST® in any way. Failure to follow this warning could result in serious injury or death in the event of a collision.



Warning: Ensure that the QUEST® and delineation used meet all federal, state, specifying agency, and local specifications.



Warning: Ensure that your assembly meets all appropriate Manual on Uniform Traffic Control Devices (MUTCD) and local standards. Failure to follow this warning could result in serious injury or death in the event of a collision.

QUEST® Model Numbers

QUEST® Product	Unassembled	Preassembled	Width	Design speed
70/TL-2	TD7024	TD7024A	24" [610 mm]	44 mph [70 kph]
	TD7030	TD7030A	30" [760 mm]	44 mph [70 kph]
	TD7036	TD7036A	36" [915 mm]	44 mph [70 kph]
100/TL-3	TD10024	TD10024A	24" [610 mm]	62 mph [100 kph]
	TD10030	TD10030A	30" [760 mm]	62 mph [100 kph]
	TD10036	TD10036A	36" [915 mm]	62 mph [100 kph]
115/TL-3 MOD	TD11524	TD11524A	24" [610 mm]	72 mph [115 kph]

System Overview

The QUEST® is available in a variety of widths and lengths.

Three QUEST® width options may be used to shield road features up to 24" [610 mm], 30" [760 mm], and 36" [915 mm] in width (p. 5).

The Steel Backup should be placed against and nest around the road feature, resulting in a shorter overall assembly length.

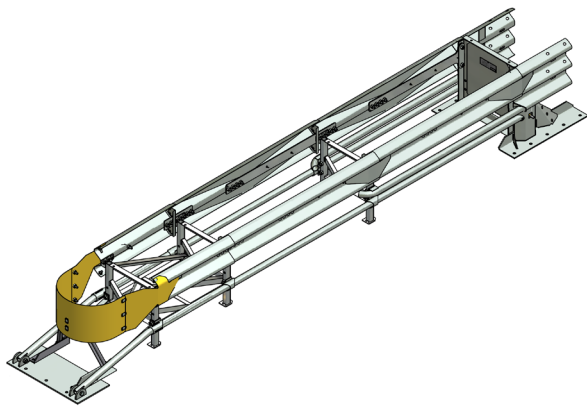

QUEST® 70/TL-2



QUEST® 100/TL-3



QUEST® 115/TL-3 MOD

**Figure 1
24" [610 mm] Systems Shown**

Selection Criteria

Selection and placement of crash cushions and end terminals must conform to and utilize devices described in:

- 1) American Association of State Highway and Transportation Officials (AASHTO) “Roadside Design Guide.”
- 2) U. S. Department of Transportation/Federal Highway Administration (FHWA) Report No. 5040.16 “Crash Cushions, Selection Criteria, and Designs.”

Special Site Conditions

Contact Valtir Customer Service Department if you would like input as to your specific application. You will need to answer the following questions:

1. **Are curbs, islands or elevated objects (delineators or signs) present at the site? What height and width are they?** All curbs and elevated objects over 4” [100 mm] high should be removed. If possible, curbs less than 4” [100 mm] high should be removed approximately 50’ [15 m] in front of the QUEST®, and as far back as the system’s backup. Any curbs that must remain should be no more than 4” [100 mm] high and mountable.
2. **If there is a cross-slope of more than 8% (5 degrees), a leveling pad must be used.**
3. If the assembly site is a gore area, (place where two roads diverge), **what is the angle of divergence.**
4. **What is the general geometry of the site**, including the roadway for 500’ [150 m] in front, so traffic patterns can be visualized?
5. **When there is an existing guardrail or median barrier at the site**, the backup of the QUEST® should tie into, or nest around it when possible.
6. **Will there be traffic approaching from the rear of the system? Is the system in a two-way traffic situation, with traffic going in opposite directions on either side of the system? Or, is the system on the side of the road in a location where crossover traffic is a concern?** If so, a transition from the back of the system to the road feature is necessary to prevent vehicle snagging (p. 52, Bidirectional Traffic).
7. **Do the foundation requirements meet or exceed the system footing specification foundation drawings in this manual?**
8. **Are there any other unique features at the site that may affect positioning or performance of the QUEST®?** (p. 52, Bidirectional Traffic)



Warning: It is the responsibility of the state or specifying agency to ensure proper site grading for QUEST® placement.

Site Preparation Foundation

Concrete Installations

The QUEST®, for permanent applications, should be installed on an existing or freshly placed and cured concrete base (4000 psi [28 MPa] minimum). Orientation of the concrete base and the attenuator must comply with the project plans or as otherwise determined by the resident project engineer or appropriate highway authority.

Recommended dimension and reinforcement specifications for new concrete pads can be found on the standard drawings.

Asphalt Installations

For asphalt installations in construction zones, QUEST® must be placed on asphalt that provides a minimum of 3" [76 mm] layer of asphalt over a minimum of 3" [76 mm] layer of **Portland Cement Concrete ("P.C.C.")**, 6" [152 mm] layer of asphalt over 6" [152 mm] layer of subbase, or 8" [200 mm] layer of asphalt with no subbase. Only 460 mm [18"] threaded rods, installed with an approved adhesive, can be used for asphalt foundations.



Important: Systems mounted on asphalt must be replaced and mounted on fresh, undisturbed asphalt if more than 10% of anchors are found to be loose, broken, or show signs of pull out. If 10% or fewer anchors are damaged, replace the damaged anchors in the existing asphalt (p. 57). Anchor bolts used on systems mounted on asphalt must be inspected every 6 months (p. 56).

The QUEST® may be installed on any of the following foundations using the specified anchorage:

Foundation A: Reinforced Concrete Pad or Roadway

Foundation: 6" [150 mm] minimum depth P.C.C. (allow seven day cure before drilling boreholes)

Anchorage: Approved adhesive with 7" [180 mm] studs 5 1/2" [140 mm] embedment

Foundation B: Asphalt over P.C.C.

Foundation: 3" [76 mm] minimum asphalt concrete (A.C.) over 3" [76 mm] minimum P.C.C.

Anchorage: Length of anchor required is 18" [460 mm] with 16 1/2" [420 mm] embedment

Foundation C: Asphalt over Subbase

Foundation: 6" [150 mm] minimum A.C. over 6" [150 mm] minimum Compacted Subbase (C.S.)

Anchorage: Approved adhesive with 18" [460 mm] studs and 16 1/2" [420 mm] embedment

Foundation D: Asphalt Only

Foundation: 8" [200 mm] minimum A.C.

Anchorage: Approved adhesive with 18" [460 mm] studs and 16 1/2" [420 mm] embedment

Valtir Approved Adhesive Anchoring System

A Valtir approved adhesive anchoring system is required to securely anchor crash cushions. Each approved adhesive kit contains adhesive, studs, nuts and washers. Both vertical and horizontal assemblies are possible using an approved adhesive anchoring system.

Vertical Assemblies

Note: Read all Valtir approved adhesive instructions before starting.

1) Prepare the Concrete Foundation



Warning: Do not allow anchoring adhesive to contact skin or eyes. See safety data sheet supplied with adhesive kit for first-aid procedures. Use only in well-ventilated area. Do not use near open flame.



Warning: It is the responsibility of the installer to maintain a safe work area including the use of standard work zone safety equipment & PPE: gloves, safety-toe shoes, and eye / ear protection.

The anchor bolts (studs) that anchor the QUEST® to any concrete foundation must be those shipped in the kit or of high strength steel (120,000 psi [830 MPa] minimum tensile strength or equal). These studs must be set in minimum 4000 psi [28 MPa] concrete. Concrete foundations must be allowed to cure a minimum of seven days before drilling anchor boreholes.

2) Drill Boreholes



Caution: It is the responsibility of the installer to consult OSHA silica respiratory standard 29 CFR 1910.134 for debris removal from borehole(s) and use Valtir approved adhesive to achieve optimum tensile strength. Do not use diamond drill bits for drilling boreholes.

Use the system anchor locations as drilling templates. Use a rotary hammer drill to drill the boreholes 7/8" [22 mm] diameter to the recommended depth. See the approved adhesive instructions provided with adhesive kit. Check to ensure each borehole is drilled to the proper depth and aligned with the part to be anchored.

Anchoring Information					
Stud Size:	Orientation	Bit Size	Minimum Depth	Torque	Medium
3/4"x 6 1/2"	Horizontal	7/8" [22 mm]	5 1/4" [133 mm]	Manufacturer Spec	Concrete
3/4"x 7"	Vertical	7/8" [22 mm]	5 3/4" [145 mm]	Manufacturer Spec	Concrete
3/4"x 18"	Vertical	7/8" [22 mm]	16 3/4" [425 mm]	10 ft-lb [15 N-m]	Asphalt



Important: When mounting on asphalt, initial torque shall be as shown in the Anchoring Information table. Due to the properties of asphalt, anchors may loosen over time. For this reason Valtir recommends anchoring to asphalt only at temporary locations. It is recommended to re-torque anchors in asphalt every six (6) months to the proper initial torque specified.

3) Clean the Boreholes

Blow the concrete dust from the borehole using oil-free compressed air. Thoroughly brush it with a 7/8" diameter steel bristle tube brush and then blow it out again. If the borehole is wet, completely flush it with water while brushing and then blow it clean to remove all water using oil-free compressed air.

4) Apply Approved Adhesive

Fill the borehole 100% full.



Caution: Fill borehole 100% full so it is even with the pavement surface per manufacturer's instructions.

5) Add Nuts to Anchor Studs

Place a flat washer onto the stud then thread a nut on until the end of the stud is flush with the NUT (Figure 2).

6) Insert Studs in Boreholes and Wait for Adhesive to Cure

Push the stud down through the part to be anchored and into the borehole. Give the stud several twists in the approved adhesive to wet the threads.



Caution: Do not disturb or load the stud until the approved adhesive material has hardened (see instructions supplied with the approved adhesive kit).

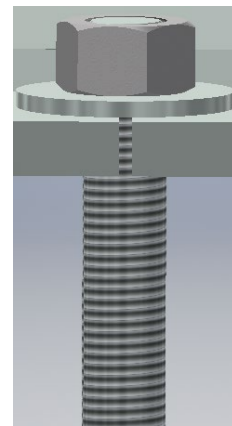

Figure 2
Vertical Application
(Before Applied Torque)

7) Torque the Nuts

Once the adhesive has fully cured, torque the nut to the adhesive manufacturer's recommended values.

Anchor Assembly Cautions

1) Steel rebar

If steel rebar is encountered while drilling an anchor bolt borehole, apply one of the following solutions:

A) Use a rebar drill bit for the **rebar only** and then switch back to the concrete bit to finish drilling into the underlying concrete until the proper borehole depth is reached.



Caution: Do not drill through rebar without first obtaining permission to do so from the project engineer.

B) Drill a new borehole down at an angle past the rebar to the proper depth. Anchor the stud by completely filling both boreholes with an approved adhesive.

Horizontal Assemblies

The horizontal approved adhesive kit is the same as the vertical kit.



Caution: Fill borehole 100% full so it is even with the surface of the hole per manufacturer's instructions.

1) Follow the instructions supplied with your approved adhesive kit

Apply approved adhesive to each anchor per instructions.

2) Add the Washers and Nuts

Put washer and nut on stud so the **nut is flush with end of stud**.

3) Insert each Stud with Washer and Nut into Borehole

Push stud with washer and nut into borehole. Twist the stud in the approved adhesive to fully wet the threads.



Important: The stud should be flush with the top of the nut in both **vertical** and **horizontal** applications prior to tightening (Figure 3).

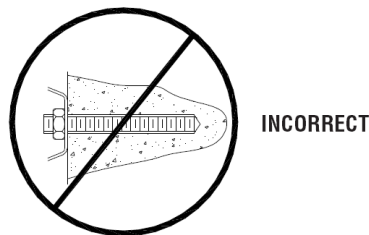
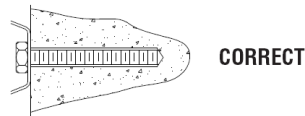

Figure 3
Horizontal Application
(Before Applied Torque)



Warning: Do not disturb or load the stud until the approved adhesive material has hardened (**see approved adhesive kit instructions for cure times and torque values**).

4) Torque the nuts

Once the adhesive has fully cured, torque nut(s) to the approved adhesive manufacturing specification.

Parts List - QUEST® 70 / TL-2			
Item	Stock No.	Description	Qty.
1	(SEE TABLE)	BACKUP, __, QUEST, G	1
2	(SEE TABLE)	SUPPORT FRAME ASSY, __, QUEST	1
3	614027G	SHAPER RAIL, L, QUEST, 80, G	1
4	614033G	SHAPER RAIL, R, QUEST, 80, G	1
5	(SEE TABLE)	ANCHOR, FRONT, QUEST, G	1
6	616230G	TRIGGER STRAP, QUEST, G	2
7	(SEE TABLE)	TRIGGER ASSY, __, QUEST	1
8	611642G	NOSE TRANSITION, R, QUEST, G, PT	1
9	611641G	NOSE TRANSITION, L, QUEST, G, PT	1
10	(SEE TABLE)	NOSE, __, QUEST, G, PT	1
11	(SEE TABLE)	DIAPHRAGM ASSY, __, QUEST	1
12	N/A		
13	613663G	REAR RAIL, QUEST, G (UNCRIMPED)	2
14	614733B	STRAP, PEEL, REAR, QUEST	2
15	614728B	STRAP, PEEL, BAY 2, QUEST	2
16	N/A		
17	608415G	FLT ST, 1/4X2 13/16X10 7/16, W/HOLES, G	2
18	608513G	FLT ST 1/4X4X14, W/SLOTS, G	2
19	611792G	PANEL, BAY 1, QUEST, G	2
20	611796G	PANEL, BAYS, QUEST, G	4
21	605343G	BRACE, PANEL, QUEST, G	4
22	116933B	SCREW, PN, #6-32X1 1/2, PHIL, S	8
23	617005G	WASHER, BAR, 1/8X1 1/4X2, ROUNDED, G	8
24	118052G	WASHER, FLAT, 5/8 X 1 3/4, G	6
25	117987B	WASHER, FLAT, #6X5/8X.030, S	16
26	617010G	WASHER, BAR, 2X2X1/4, G	2
27	118030G	WASHER, FLAT, 3/8 ID X13/16 OD, P, HRD	32
28	003340G	NUT, HX, 5/8, G, RAIL	60
29	115914B	NUT, HX, #6-32, S	16
30	003704G	NUT, HX, 3/4", GR DH	10
31	N/A		
32	N/A		
33	115971G	NUT, HX, 5/8, G, GR DH	6
34	N/A		
35	113553G	BOLT, HX, 3/4X2, G5, G	4
36	113538G	BOLT, HX, 1X5, G8, G	2
37	113530G	BOLT, HX, 1X3 1/2, G5, G	2
38	113654G	BOLT, HX, 5/8X1 1/2, G5, G	6
39	113558G	BOLT, HX, 3/4X3 1/2, G5, G	2
40	113596G	BOLT, HX, 3/8X1, G2, G	16
41	113568G	BOLT, HX, 3/4X4, G5, G, ALL THRD	2
42	003400G	BOLT, RAIL, 5/8X2, G	54
43	614533B	SPACER, RAIL TENSION, QUEST	2
44	118027G	WASHER, FLAT, 3/4X2, HVY, G	2

System Width Table Reference				
ITEM	24"/610 mm	30"/760 mm	36"/915 mm	DESCRIPTION
1	604647G	604648G	604650G	BACKUP, __, QUEST, G
2	615467B	615443B	615444B	SUPPORT FRAME ASSY, __, QUEST
5	617605G	617613G	617616G	ANCHOR, FRONT, QUEST, __, G
7	616212B	616208B	616209B	TRIGGER ASSY, __, QUEST
10	611678W	611650W	611651W	NOSE, __, QUEST, G, PT
11	607196B	606806B	606808B	DIAPHRAGM ASSY, __, QUEST

Parts List - QUEST® 100 / TL-3			
Item	Stock No.	Description	Qty.
1	(SEE TABLE)	BACKUP, __, QUEST, G	1
2	(SEE TABLE)	SUPPORT FRAME ASSY, __, QUEST	1
3	614029G	SHAPER RAIL, L, QUEST, G	1
4	614035G	SHAPER RAIL, R, QUEST, G	1
5	(SEE TABLE)	ANCHOR, FRONT, QUEST, G	1
6	616230G	TRIGGER STRAP, QUEST, G	2
7	(SEE TABLE)	TRIGGER ASSY, __, QUEST	1
8	611642G	NOSE TRANSITION, R, QUEST, G, PT	1
9	611641G	NOSE TRANSITION, L, QUEST, G, PT	1
10	(SEE TABLE)	NOSE, __, QUEST, G, PT	1
11	(SEE TABLE)	DIAPHRAGM ASSY, __, QUEST	2
12	614042G	SHAPER, BACKUP, QUEST, G	2
13	613662G	REAR RAIL, QUEST, G	2
14	614733B	STRAP, PEEL, REAR, QUEST	2
15	614728B	STRAP, PEEL, BAY 2, QUEST	2
16	614732B	STRAP, PEEL, BAY 3, QUEST	2
17	608415G	FLT ST, 1/4X2 13/16X10 7/16, W/HOLES, G	2
18	608513G	FLT ST 1/4X4X14, W/SLOTS, G	2
19	611792G	PANEL, BAY 1, QUEST, G	2
20	611796G	PANEL, BAYS, QUEST, DCM, G	6
21	605343G	BRACE, PANEL, QUEST CEN, G	6
22	116933B	SCREW, PN, #6-32X1 1/2, PHIL, S	12
23	617005G	WASHER, BAR, 1/8X1 1/4X2, ROUNDED, G	8
24	118052G	WASHER, FLAT, 5/8 X 1 3/4, G	6
25	117987B	WASHER, FLAT, #6X5/8X.030, S	24
26	617010G	WASHER, BAR, 2X2X1/4, G	2
27	118030G	WASHER, FLAT, 3/8 ID X13/16 OD, P, HRD	48
28	003340G	NUT, HX, 5/8, G, RAIL	78
29	115914B	NUT, HX, #6-32, S	24
30	003704G	NUT, HX, 3/4", GR DH	12
31	115931G	NUT, HX, 1, G	2
32	115960G	NUT, HX, 3/8, G	24
33	N/A		
34	N/A		
35	113553G	BOLT, HX, 3/4X2, G5, G	4
36	113538G	BOLT, HX, 1X5, G8, G	2
37	113530G	BOLT, HX, 1X3 1/2, G5, G	2
38	113654G	BOLT, HX, 5/8X1 1/2, G5, G	6
39	113558G	BOLT, HX, 3/4X3 1/2, G5, G	4
40	113596G	BOLT, HX, 3/8X1, G2, G	24
41	113568G	BOLT, HX, 3/4X4, G5, G, ALL THRD	2
42	003400G	BOLT, RAIL, 5/8X2, G	72
43	614533B	SPACER, RAIL TENSION, QUEST	2
44	118027G	WASHER, FLAT, 3/4X2, HVY, G	2

System Width Table Reference				
ITEM	24"/610 mm	30"/760 mm	36"/915 mm	DESCRIPTION
1	604647G	604648G	604650G	BACKUP, __, QUEST, G
2	615467B	615443B	615444B	SUPPORT FRAME ASSY, __, QUEST
5	617605G	617613G	617616G	ANCHOR, FRONT, QUEST, __, G
7	616212B	616208B	616209B	TRIGGER ASSY, __, QUEST
10	611678W	611650W	611651W	NOSE, __, QUEST, G, PT
11	607196B	606806B	606808B	DIAPHRAGM ASSY, __, QUEST

Parts List - QUEST® 115 / TL-3 MOD			
Item	Stock No.	Description	Qty.
1	(SEE TABLE)	BACKUP, __,QUEST,G	1
2	(SEE TABLE)	SUPPORT FRAME ASSY, __,QUEST	1
3	614029G	SHAPER RAIL,L,QUEST,G	1
4	614035G	SHAPER RAIL,R,QUEST,G	1
5	(SEE TABLE)	ANCHOR,FRONT,QUEST,G	1
6	616230G	TRIGGER STRAP,QUEST,G	2
7	(SEE TABLE)	TRIGGER ASSY, __,QUEST	1
8	611642G	NOSE TRANSITION,R,QUEST,G,PT	1
9	611641G	NOSE TRANSITION,L,QUEST,G,PT	1
10	(SEE TABLE)	NOSE, __,QUEST,G,PT	1
11	(SEE TABLE)	DIAPHRAGM ASSY, __,QUEST	3
12	614042G	SHAPER,BACKUP,QUEST,G	2
13	613662G	REAR RAIL,QUEST,G	2
14	614733B	STRAP,PEEL,REAR,QUEST	2
15	614728B	STRAP,PEEL,BAY 2,QUEST	4
16	614732B	STRAP,PEEL, BAY 3,QUEST	2
17	608415G	FLT ST, 1/4X2 13/16X10 7/16,W/HOLES,G	2
18	608513G	FLT ST 1/4X4X14,W/SLOTS,G	2
19	611792G	PANEL,BAY 1,QUEST,G	2
20	611796G	PANEL,BAYS,QUEST,DCM,G	8
21	605343G	BRACE,PANEL,QUEST CEN,G	8
22	116933B	SCREW,PN,#6-32X1 1/2,PHIL,S	16
23	617005G	WASHER,BAR,1/8X1 1/4X2,ROUNDED,G	8
24	118052G	WASHER,FLAT,5/8 X 1 3/4, G	6
25	117987B	WASHER,FLAT,#6X5/8X.030,S	32
26	617010G	WASHER,BAR,2X2X1/4,G	2
27	118030G	WASHER,FLAT,3/8 ID X13/16 OD,P,HRD	64
28	003340G	NUT,HX,5/8,G,RAIL	96
29	115914B	NUT,HX,#6-32,S	32
30	003704G	NUT,HX,3/4",GR DH	12
31	115931G	NUT,HX,1,G	2
32	115960G	NUT,HX,3/8,G	32
33	N/A		
34	N/A		
35	113553G	BOLT,HX,3/4X2,G5,G	4
36	113538G	BOLT,HX,1X5,G8,G	2
37	113530G	BOLT,HX,1X3 1/2,G5,G	2
38	113654G	BOLT,HX,5/8X1 1/2,G5,G	6
39	113558G	BOLT,HX,3/4X3 1/2,G5,G	6
40	113596G	BOLT,HX,3/8X1,G2,G	32
41	113568G	BOLT,HX,3/4X4,G5,G,ALL THRD	2
42	003400G	BOLT,RAIL,5/8X2,G	90
43	614533B	SPACER,RAIL TENSION,QUEST	2
44	118027G	WASHER,FLAT,3/4X2,HVY,G	2

System Width Table Reference				
ITEM	24"/610 mm	30"/760 mm	36"/915 mm	DESCRIPTION
1	604647G	604648G	604650G	BACKUP, __,QUEST,G
2	615467B	615443B	615444B	SUPPORT FRAME ASSY, __,QUEST
5	617605G	617613G	617616G	ANCHOR,FRONT,QUEST, __,G
7	616212B	616208B	616209B	TRIGGER ASSY, __,QUEST
10	611678W	611650W	611651W	NOSE, __,QUEST,G,PT
11	607196B	606806B	606808B	DIAPHRAGM ASSY, __,QUEST

Parts Identification

Inspect Shipping

Before assembling the QUEST®, check the received parts against the **shipping list supplied with the system**. Make sure all parts have been received.

Note: The parts lists shown on the following pages are for reference only and may not be up to date. For the most accurate parts lists, please refer to the drawing package supplied with the system.

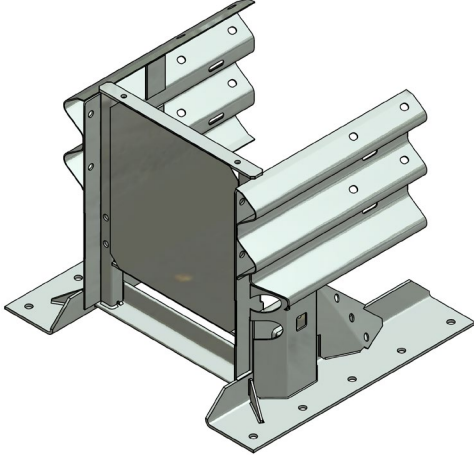
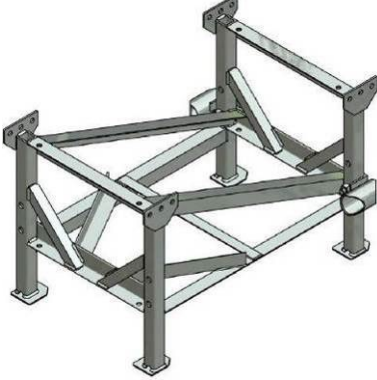
	<p>ITEM 1</p> <p>604647G BACKUP, 24"/610 mm, QUEST,G (1) or 604648G BACKUP, 30"/760 mm, QUEST,G (1) or 604650G BACKUP, 36"/915 mm ,QUEST,G (1)</p>
	<p>ITEM 2</p> <p>615467B SUPPORT FRAME ASSY, 24"/610 mm, QUEST (1) or 615443B SUPPORT FRAME ASSY, 30"/760 mm, QUEST (1) or 615444B SUPPORT FRAME ASSY, 36"/915 mm, QUEST (1)</p>

	<p>ITEM 3</p> <p>614027G SHAPER RAIL,L, QUEST 70/TL-2,G (1) or 614029G SHAPER RAIL,L, QUEST 100/TL-3,G (1) or 614025G SHAPER RAIL,L, QUEST 115/TL-3 MOD,G (1)</p>
	<p>ITEM 4</p> <p>614033G SHAPER RAIL, R, QUEST 70/TL-2,G (1) or 614035G SHAPER RAIL, R, QUEST 100/TL-3,G (1) or 614031G SHAPER RAIL,R, QUEST 115/TL-3 MOD,G (1)</p>
	<p>ITEM 5</p> <p>6176056 ANCHOR,FRONT, QUEST, 24"/610 mm, G (1) or 617613G ANCHOR,FRONT, QUEST, 30"/760 mm, G (1) or 617616G ANCHOR,FRONT, QUEST, 36"/915 mm, G (1)</p>
	<p>ITEM 6</p> <p>616230G TRIGGER STRAP,QUEST, G,PT (1)</p>
	<p>ITEM 7</p> <p>616212B TRIGGER ASSY, 24"/610 mm, QUEST (1) or 616208G TRIGGER ASSY, 30"/760 mm, QUEST (1) or 616209B TRIGGER ASSY, 36"/915 mm ,QUEST (1)</p>

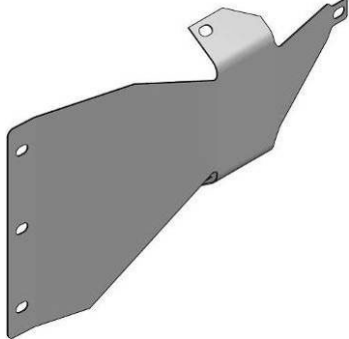
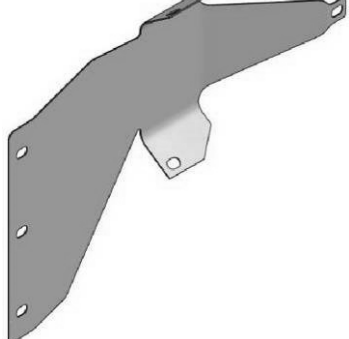
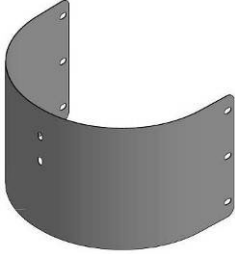
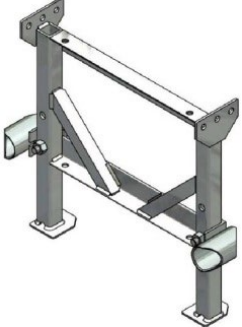
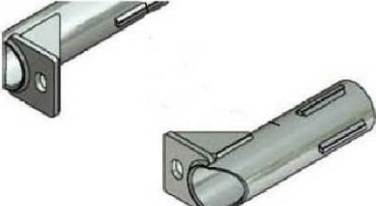
	<p>ITEM 8</p> <p>611642G NOSE TRANSITION,R,QUEST,G,PT</p>
	<p>ITEM 9</p> <p>611641G NOSE TRANSITION,L,QUEST,G,PT</p>
	<p>ITEM 10</p> <p>611678G NOSE, 24"/610mm, QUEST,G,PT(1) or 611650G NOSE, 30"/760mm, QUEST,G,PT(1) or 611651G NOSE, 36"/915 mm, QUEST,G,PT (1)</p>
	<p>ITEM 11</p> <p>607146B DIAPHRAGM ASSY, 24"/610mm, QUEST or 606806B DIAPHRAGM ASSY, 30"/760mm, QUEST or 606808B DIAPHRAGM ASSY, 36"/915 mm, QUEST</p>
	<p>ITEM 12</p> <p>614042G SHAPER,BACKUP, QUEST,G (2) QUEST 100/TL-3 and QUEST 115/TL-3 MOD</p>

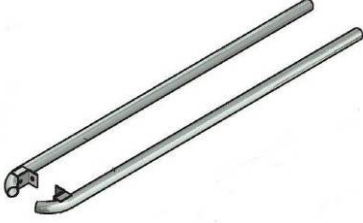
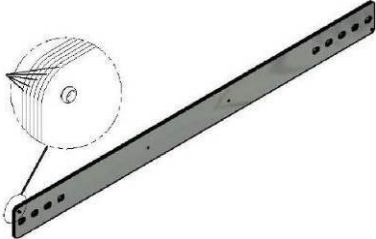
	<p>ITEM 13</p> <p>613663G REAR RAIL, QUEST UNCRIMPED,G (2) QUEST® 70/TL-2 only</p> <p>613662G REAR RAIL,QUEST,G (2) QUEST® 100/TL-3 and QUEST® 115/TL-3 MOD</p>
	<p>ITEM 14</p> <p>614733B STRAP,PEEL,REAR, QUEST (2)</p>
	<p>ITEM 15</p> <p>614728B STRAP,PEEL,BAY 2, QUEST QUEST® 70/TL-2 (2) only</p>
	<p>ITEM 16</p> <p>614732B STRAP,PEEL, BAY 3, QUEST (2) QUEST®100/TL-3 and QUEST® 115/TL-3 MOD</p>
	<p>ITEM 17</p> <p>608415B FLT ST 1/4X2 13/16x10 7/17, W/HOLES,6 (2) QUEST® 100/TL-3 and QUEST® 115/TL-3 MOD</p>
	<p>ITEM 18</p> <p>608513G FLT ST 1/4X4X14,W/SLOTS,G (2)</p>

	<p>ITEM 19</p> <p>611792G PANEL,BAY 1, QUEST,G (2)</p>
	<p>ITEM 20</p> <p>611796G PANEL,BAYS, QUEST,GQUEST® 70/TL-2 (4) QUEST® 100/TL-3 (6)QUEST® 115/TL-3 MOD (8)</p>
	<p>ITEM 21</p> <p>605343G BRACE,PANEL, QUEST,G QUEST® 70/TL-2 (4) QUEST® 100/TL-3 (6) QUEST® 115/TL-3 MOD (8)</p>
	<p>ITEM 43</p> <p>614533B SPACER,RAIL,TENSION, QUEST, PT,Y (2)</p>



ITEM 22 116933B SCREW,PN,#6-32X1 1/2,PHIL,S
QUEST® 70/TL-2 (8)
QUEST® 100/TL-3 (12)
QUEST® 115/TL-3 MOD (16)

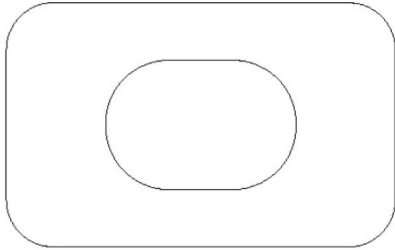

ITEM 23 617005G WASHER, BAR, 1/8X1 1/4X2
ROUNDED. G (8)

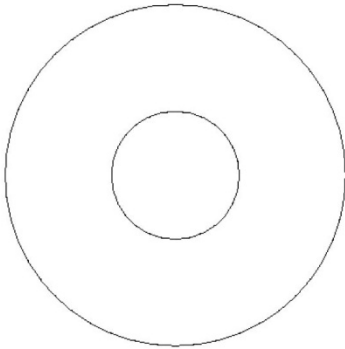

ITEM 24 118052G WASHER, FLAT, 5/8X1 3/4, G (6)

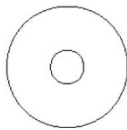

ITEM 25 117987B WASHER, FLAT, #6X5/8X.030, S
QUEST® 70/TL-2 (16)
QUEST® 100/TL-3 (24)
QUEST® 115/TL-3 MOD (32)

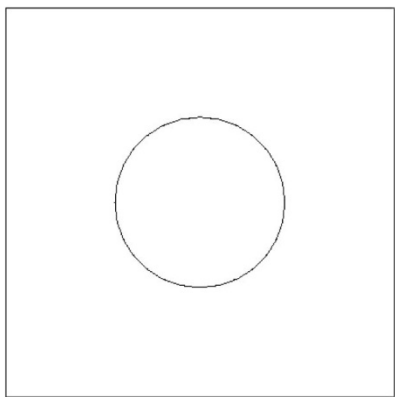

ITEM 26 617010G WASHER, BAR,
2X2X1/4, G (2)

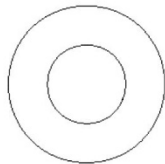

ITEM 27 118030G WASHER, FLAT,
3/8 ID X 13/16 OD, P, HRD
QUEST® 70/TL-2 (32)
QUEST® 100/TL-3 (48)
QUEST® 115/TL-3 MOD (64)

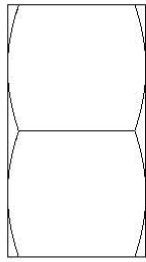
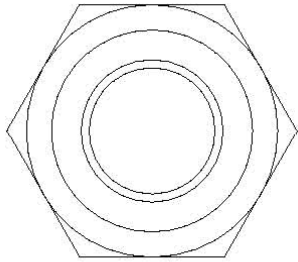

ITEM 28 003340G NUT, HX, 5/8, G, RAIL
QUEST® 70/TL-2 (60)
QUEST® 100/TL-3 (78)
QUEST® 115/TL-3 MOD (96)



ITEM 29 115914B NUT, HX, 6-32, S
QUEST® 70/TL-2 (16)
QUEST® 100/TL-3 (24)
QUEST® 115/TL-3 MOD (32)

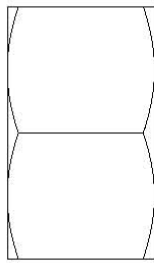
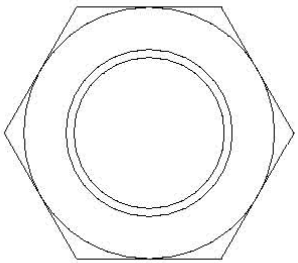

ITEM 30 003704G NUT, HX, 3/4, GR DH
QUEST® 70/TL-2 (10)
QUEST® 100/TL-3 (12)
QUEST® 115/TL-3 MOD (12)

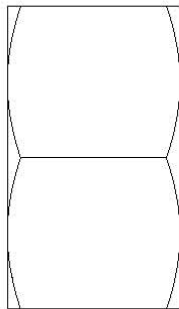
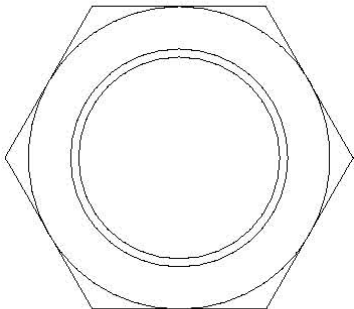

ITEM 31 115931G NUT, HX, 1, G (2)

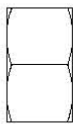
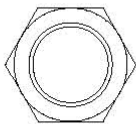

ITEM 32 115960G NUT, HX, 3/8, G
QUEST® 70/TL-2 (16)
QUEST® 100/TL-3 (24)
QUEST® 115/TL-3 MOD (32)

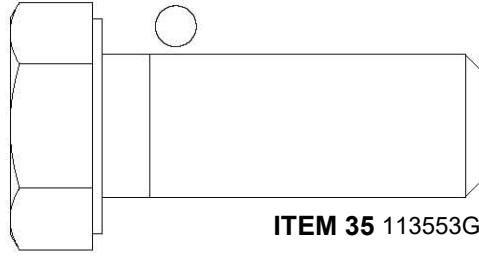
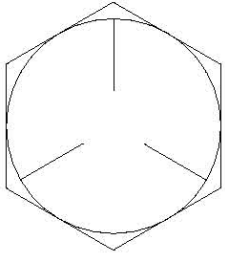

ITEM 35 113553G BOLT, HX, 3/4X2, G5, G (4)

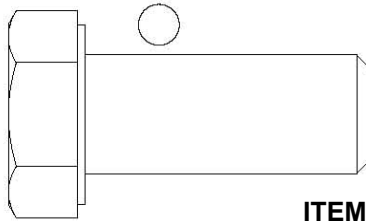
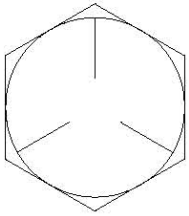

ITEM 38 113654G BOLT, HX, 5/8X1 1/2, G5, G (6)

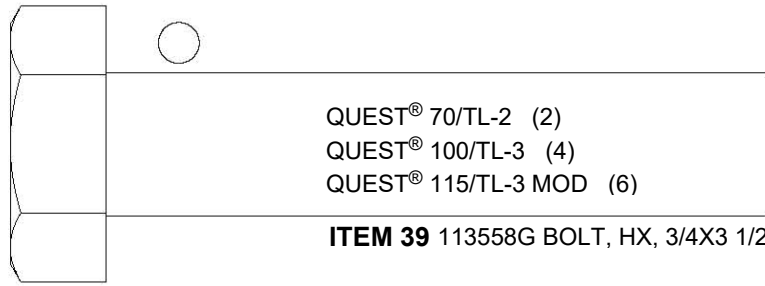
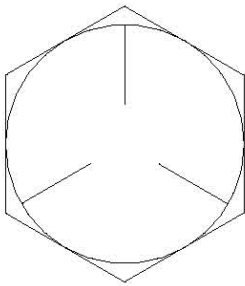

QUEST® 70/TL-2 (2)
QUEST® 100/TL-3 (4)
QUEST® 115/TL-3 MOD (6)

ITEM 39 113558G BOLT, HX, 3/4X3 1/2, G5, G

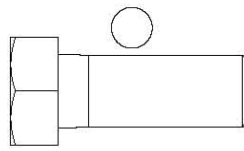
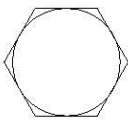

QUEST® 70/TL-2 (16)
QUEST® 100/TL-3 (24)
QUEST® 115/TL-3 MOD (32)

ITEM 40 113596G BOLT, HX, 3/8X1, G2, G

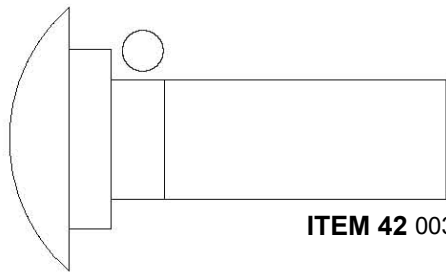
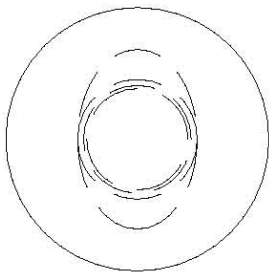

QUEST® 70/TL-2 (54)
QUEST® 100/TL-3 (72)
QUEST® 115/TL-3 MOD (90)

ITEM 42 003400G BOLT, RAIL, 5/8X2, G

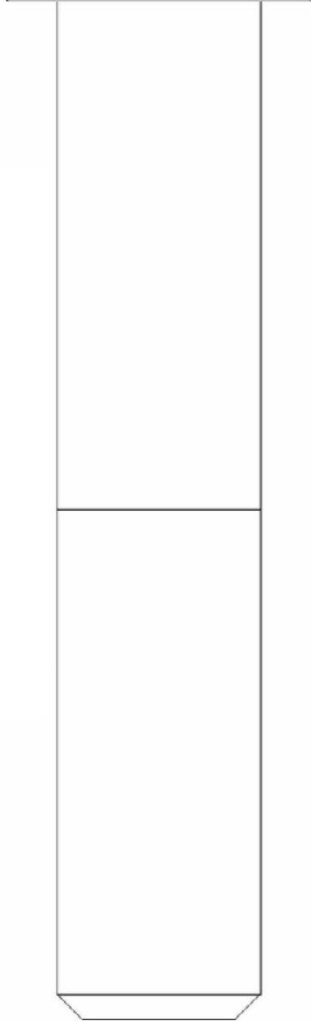
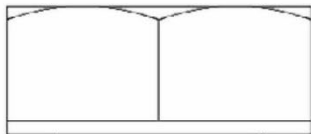
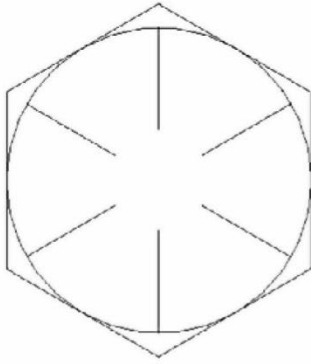

ITEM 36 113538G BOLT,
HX, 3/4X2, G5, G (4)

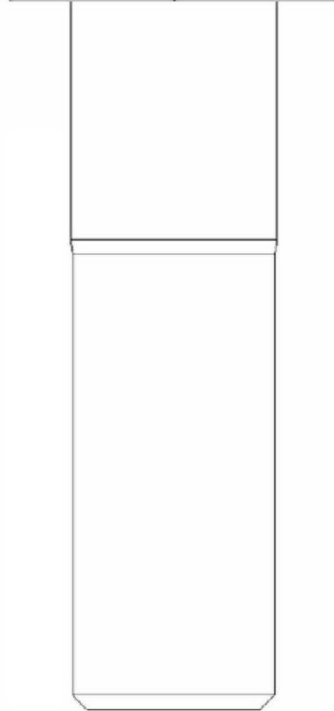
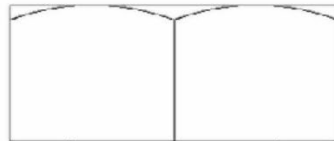
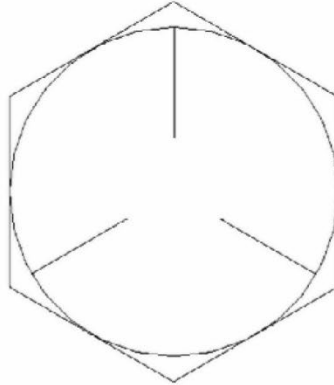

ITEM 37 113530G BOLT,
HX, 3/4X2, G5, G (4)

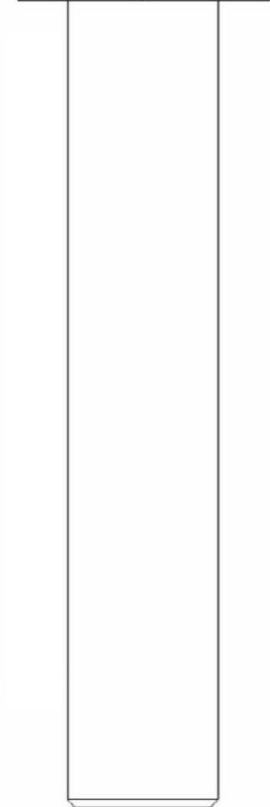
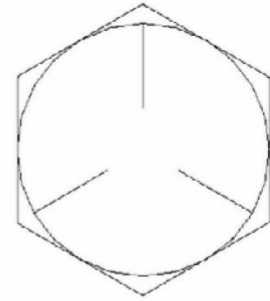

ITEM 41 113568G BOLT,
HX, 3/4X2, G5, G (4)

Pictorial Assembly

Step 1

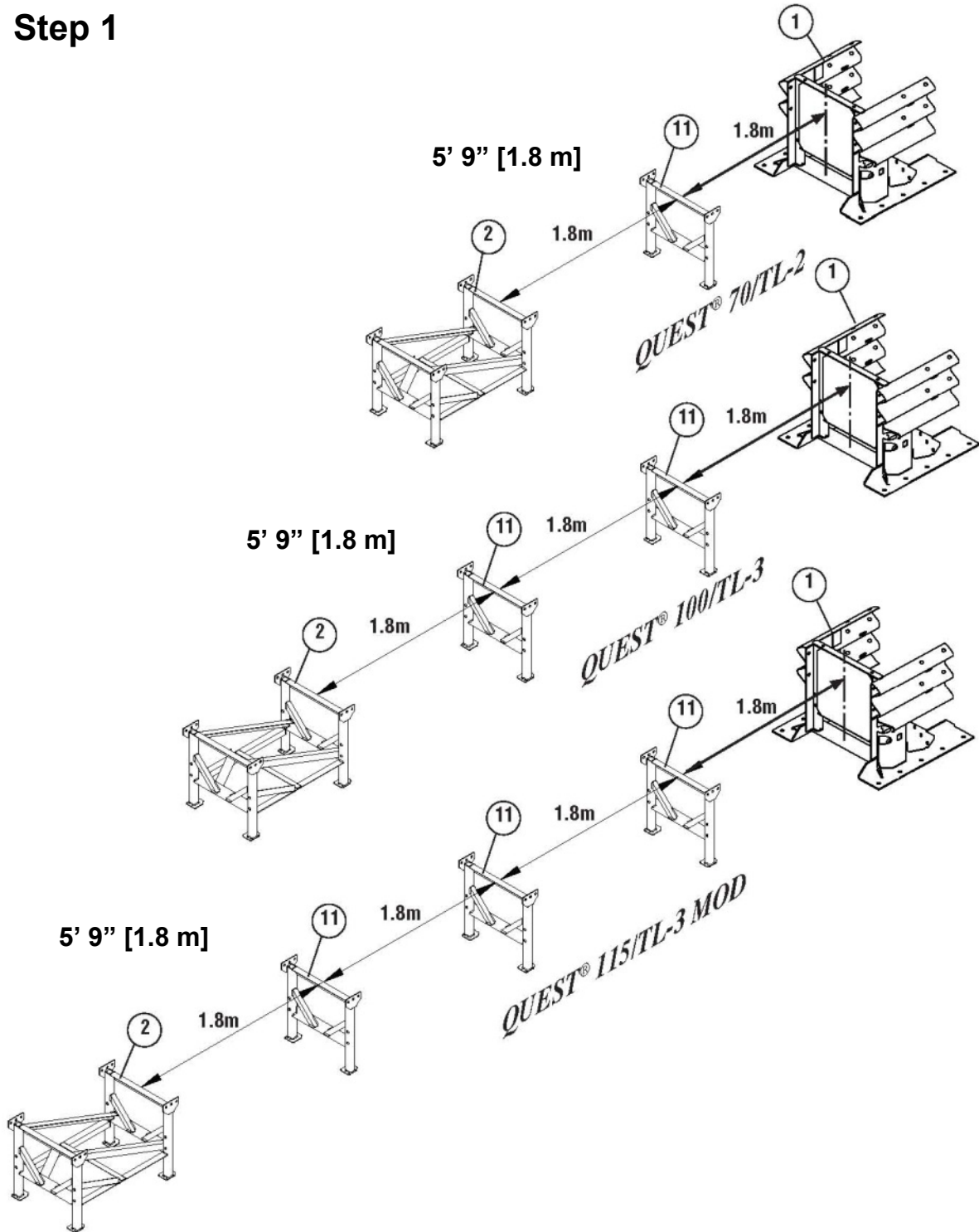

Step 2

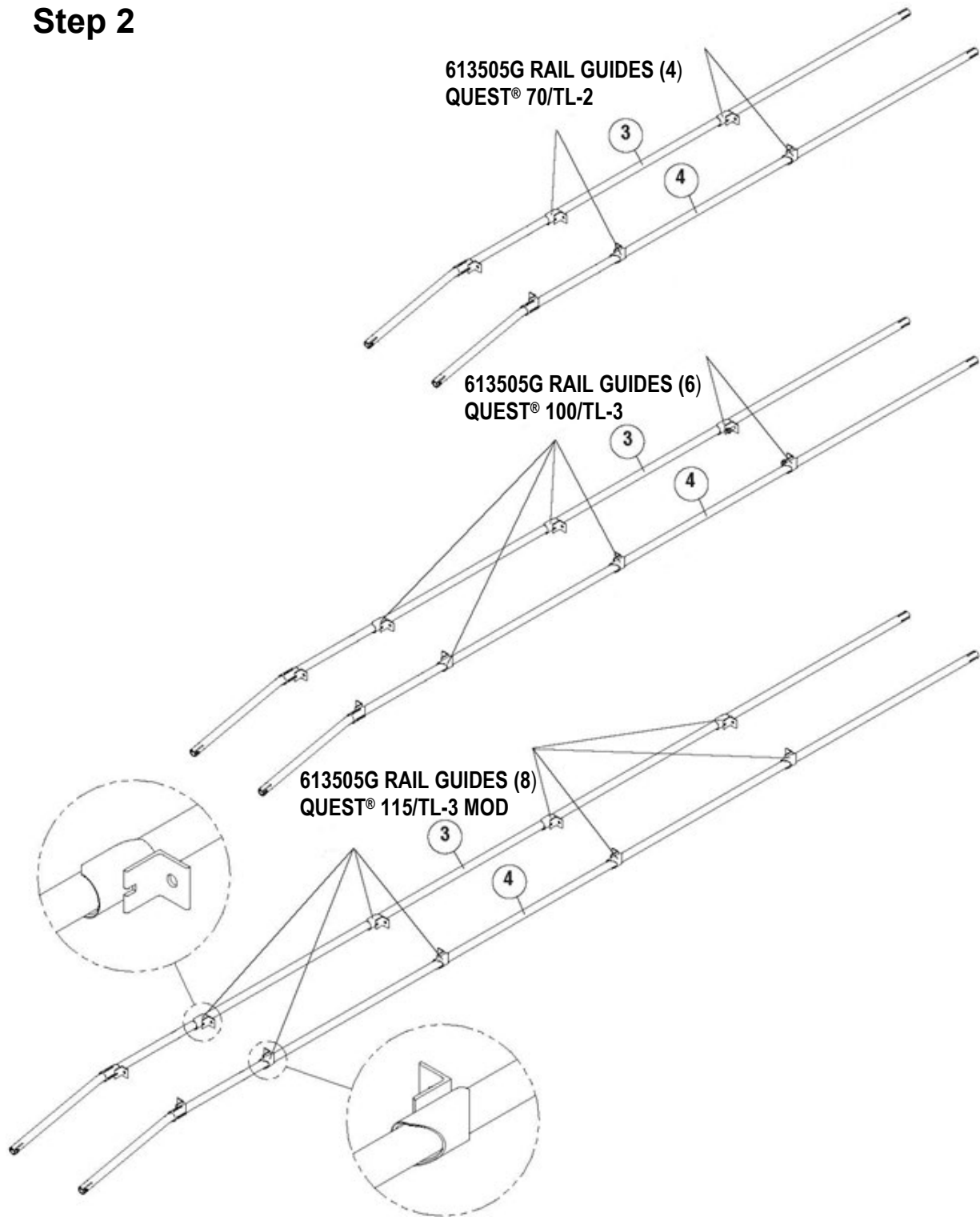

Step 3 (QUEST 70/TL-2)

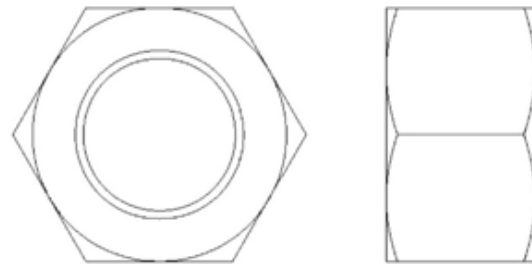
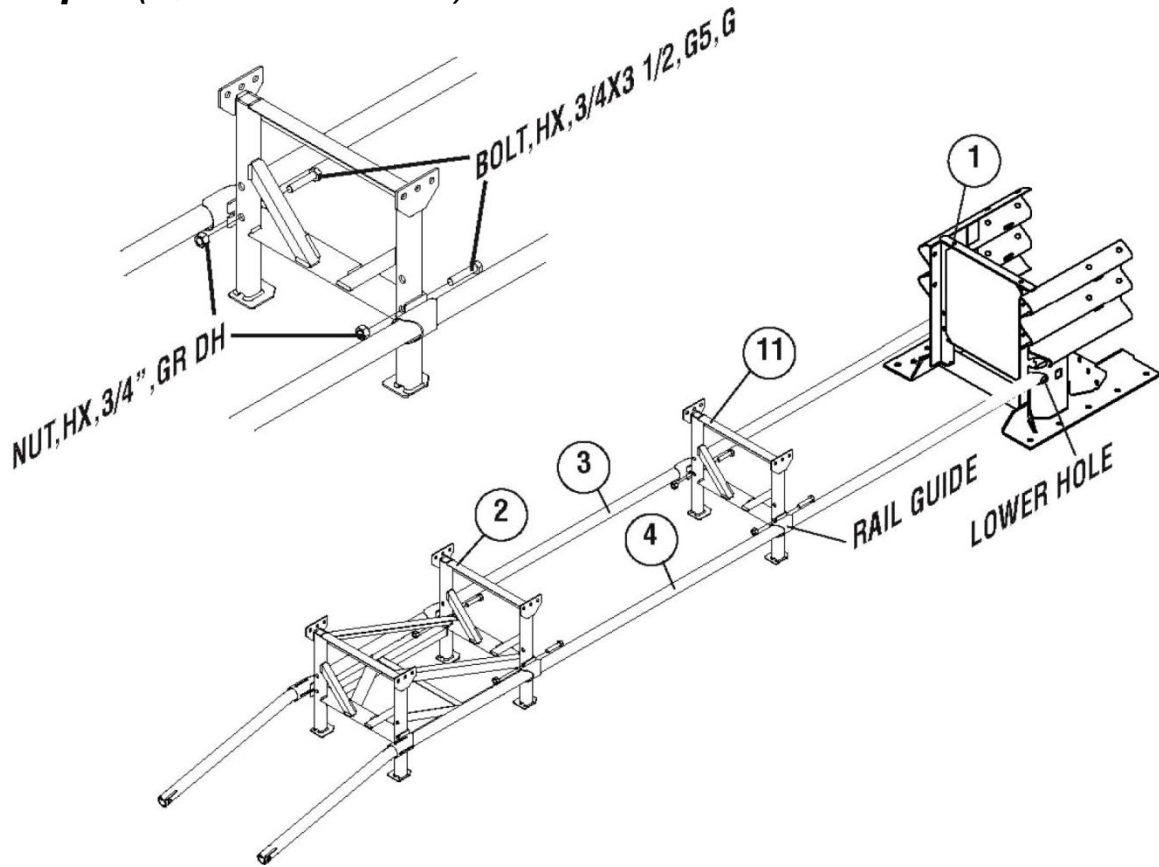

ITEM 30 003704G NUT, HX, 3/4", GR DH (4)

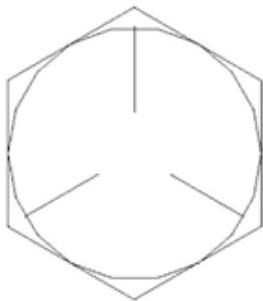

ITEM 39 113558G BOLT, HX, 3/4X3 1/2, G5, G (4)

Step 3 (QUEST® 100/TL-3)

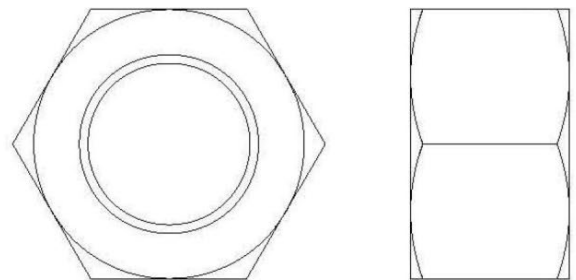
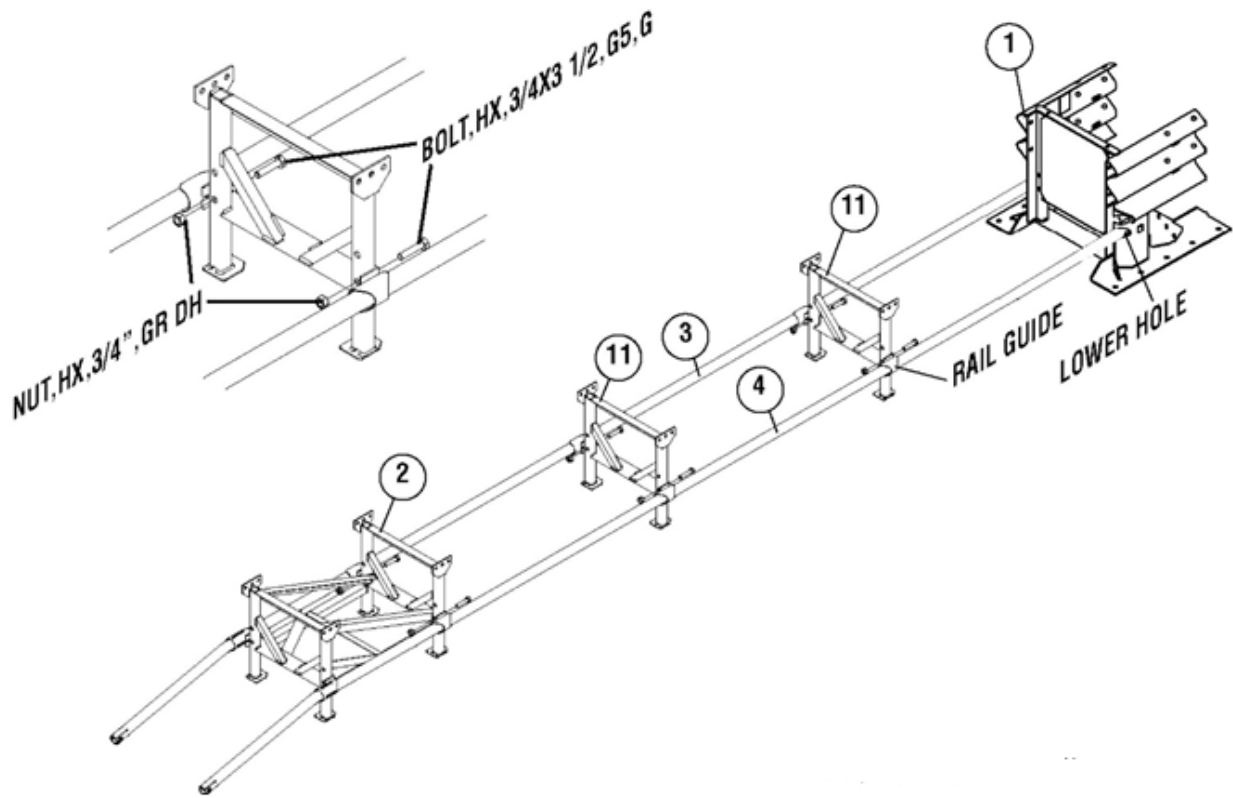

ITEM 30 003704G NUT, HX, 3/4", GR DH (6)

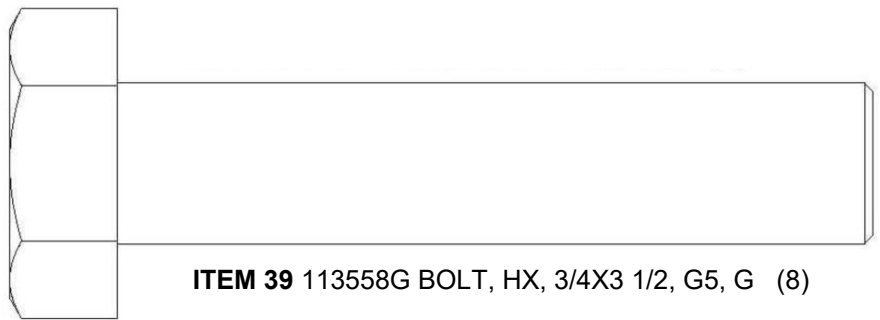
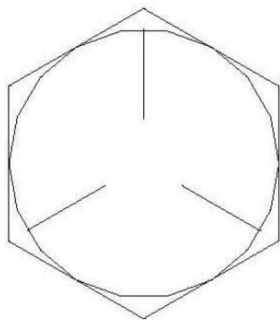

ITEM 39 113558G BOLT, HX, 3/4X3 1/2, G5, G (8)

Step 3 (QUEST® 115/TL-3 MOD)

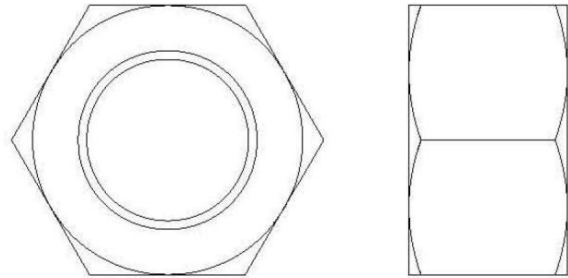
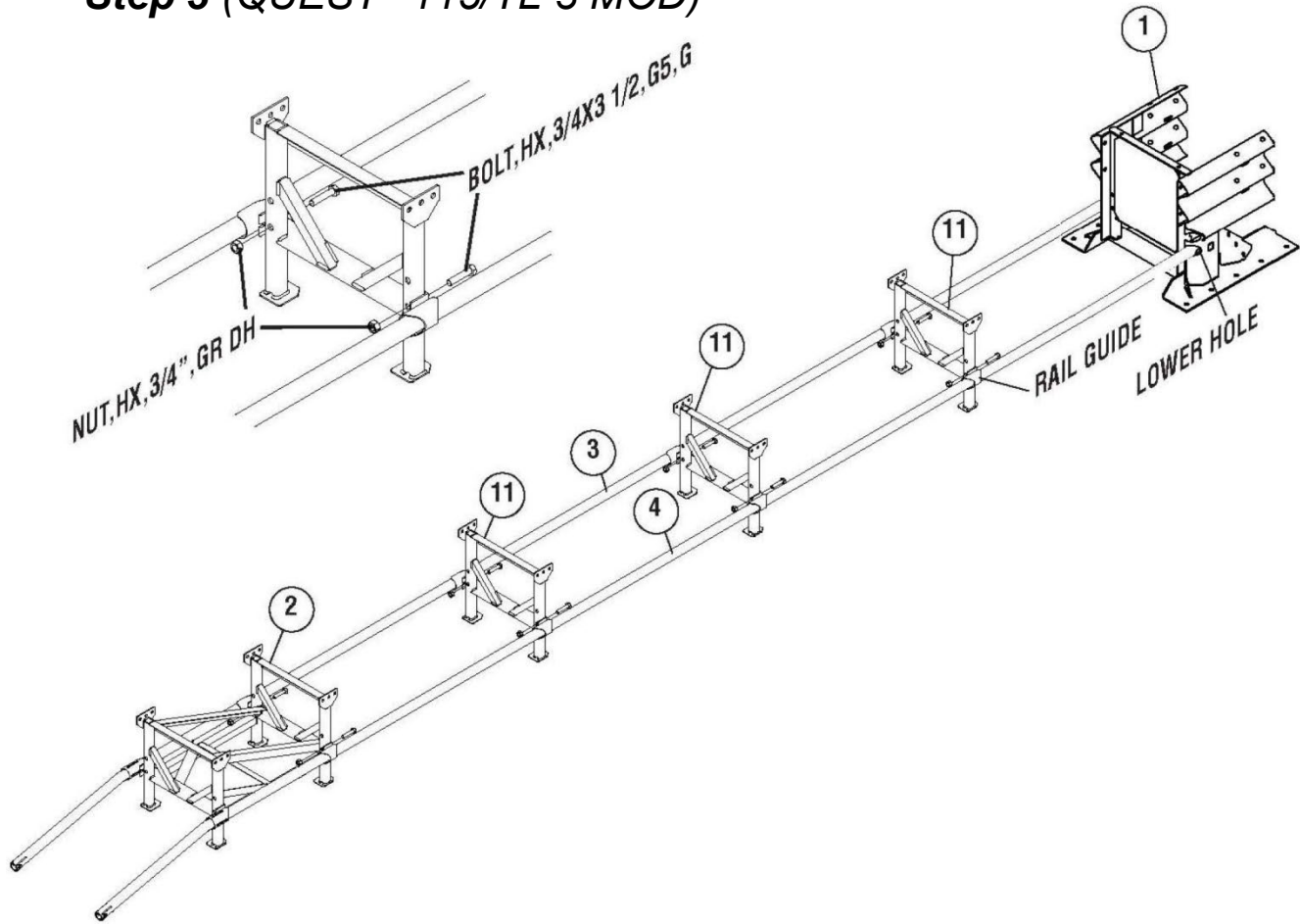

ITEM 30 003704G NUT, HX, 3/4", GR DH (8)

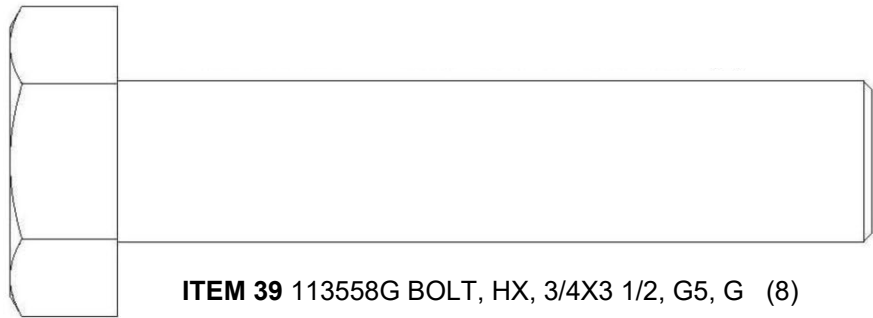
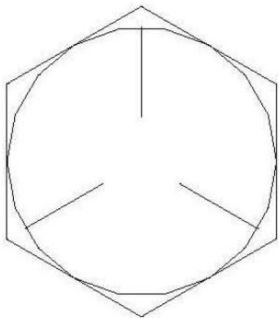

ITEM 39 113558G BOLT, HX, 3/4X3 1/2, G5, G (8)

Step 4

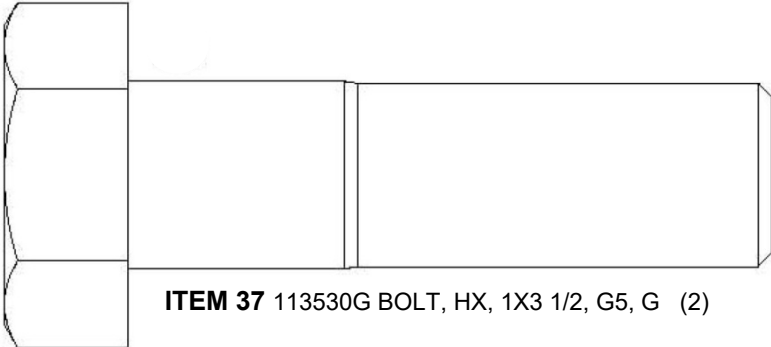
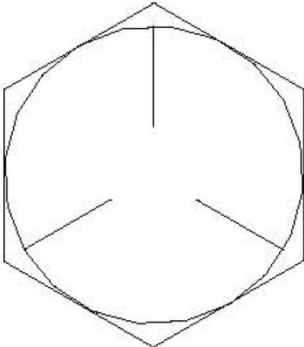
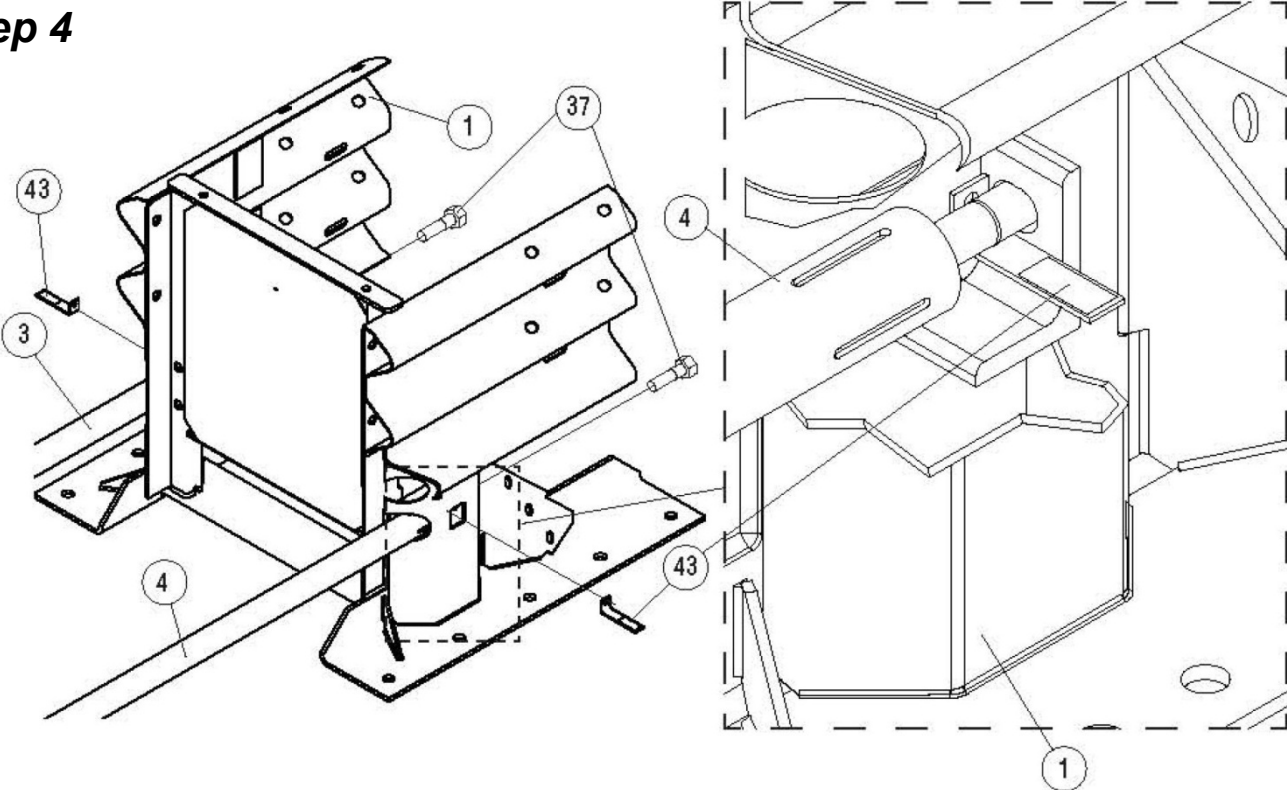

ITEM 37 113530G BOLT, HX, 1X3 1/2, G5, G (2)



ITEM 43 614534G SPACER, RAIL TENSION, QUEST®, PT, Y (2)

Step 5

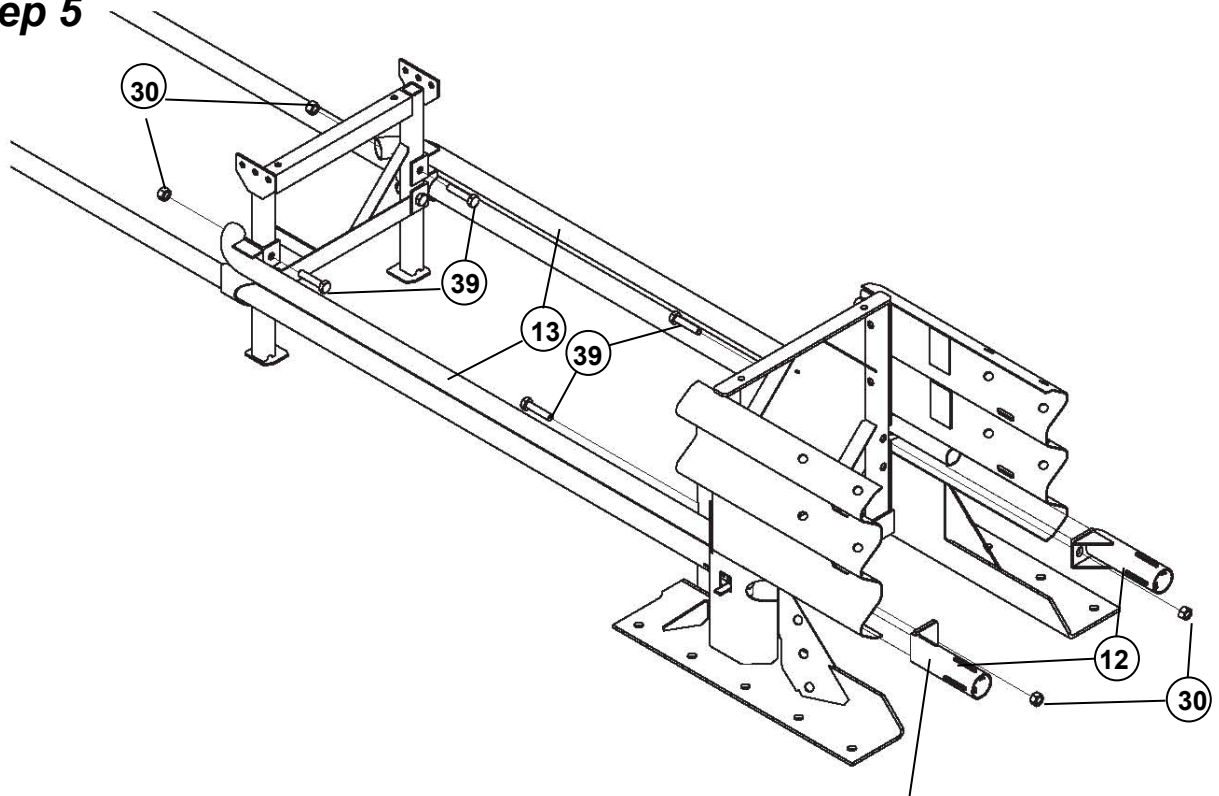

QUEST® 100/TL-3 AND QUEST® 115/TL-3 MOD

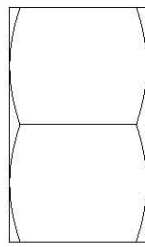
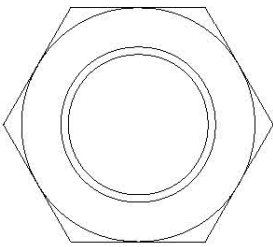

ITEM 30 003704G NUT, HX, 3/4, GR, DH (4)
 QUEST® 70/TL-2 (8)
 QUEST® 100/TL-3 (12)
 QUEST® 115/TL-3 MOD (16)

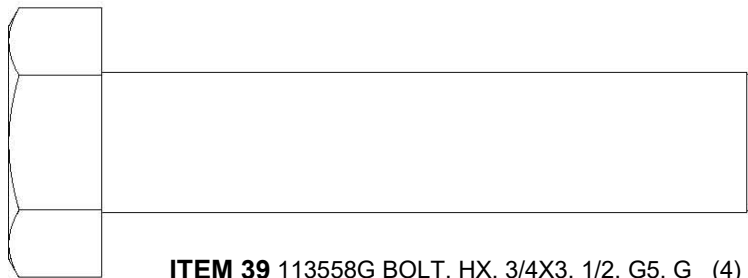
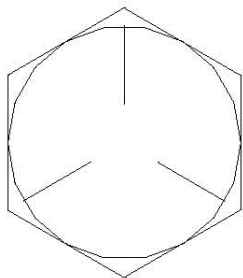

ITEM 39 113558G BOLT, HX, 3/4X3, 1/2, G5, G (4)
 QUEST® 70/TL-2 (8)
 QUEST® 100/TL-3 (12)
 QUEST® 115/TL-3 MOD (16)

Step 6

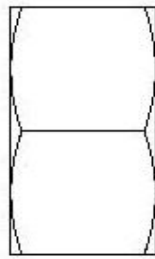
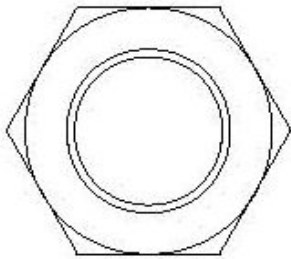
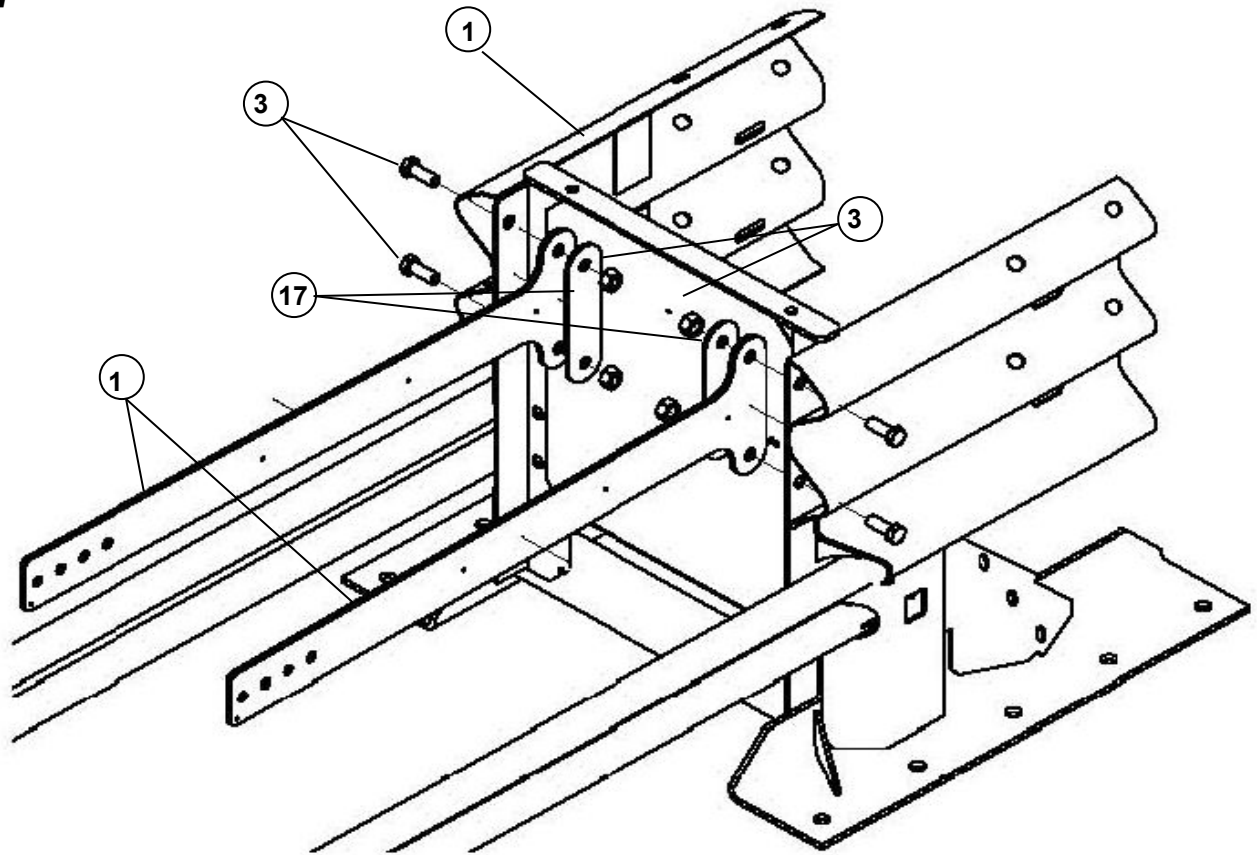

ITEM 30 003704G NUT, HX, 3/4, GR DH

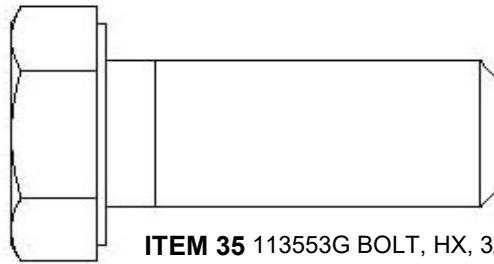
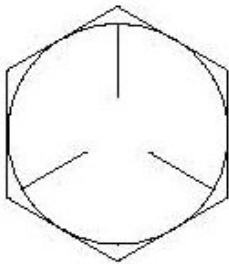

ITEM 35 113553G BOLT, HX, 3/4X2, G5, G (4)

Step 7



ITEM 22 116933B SCREW, PN, #6-32X1 1/2, PHIL, S (4)



ITEM 25 117987B WASHER, FLAT, #6X5/8X.030, S (8)



ITEM 27 118030G WASHER.FLAT, 3/8 ID X 13/16 OD, P, HRD (16)



ITEM 28 003340G NUT, HX, 5/8, G, RAIL (18)



ITEM 29 115914B NUT, HX, #6-32, S (8)



ITEM 32 115960G NUT, HX, 3/8, G (8)

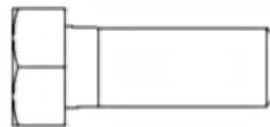

ITEM 40 113596G BOLT, HX, 3/8X1, G2, G (8)

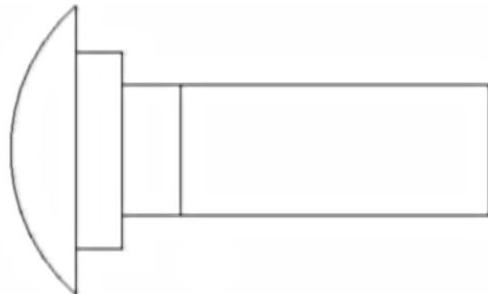
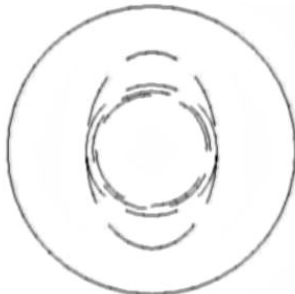

ITEM 42 003400G BOLT RAIL, 5/8X2, G (18)

Step 7 (CONT'D)

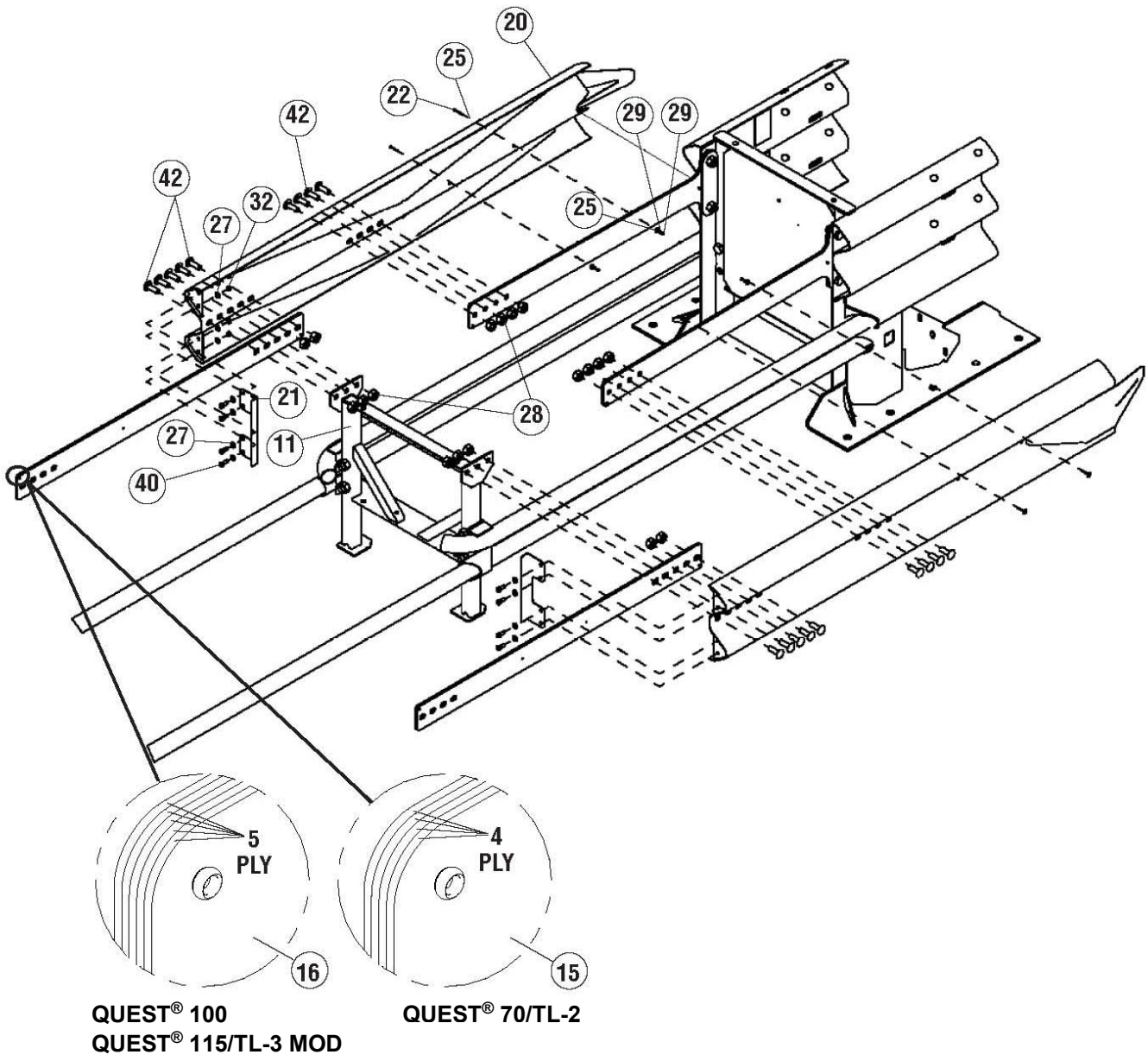



ITEM 22 116933B SCREW, #6-32X1 1/2, PHIL, S (4)

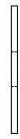
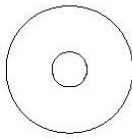

ITEM 25 117987B WASHER, FLAT, #6X5/8X.030, S (8)

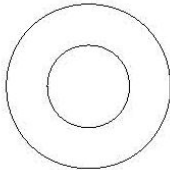

ITEM 27 118030G WASHER.FLAT, 3/8 ID X 13/16 OD, P, HRD (16)

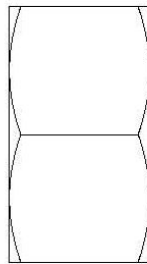
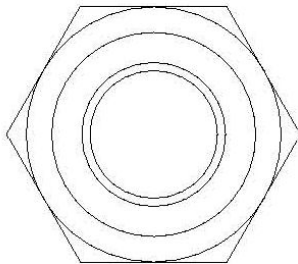

ITEM 28 003340G NUT, HX, 5/8, G, RAIL (18)



ITEM 29 115914B NUT, HX, #6-32, S (8)

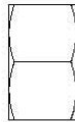
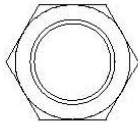

ITEM 32 115960G NUT, HX, 3/8, G (8)

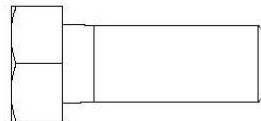
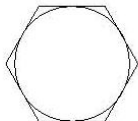

ITEM 40 113596G BOLT, HX, 3/8X1, G2, G (8)

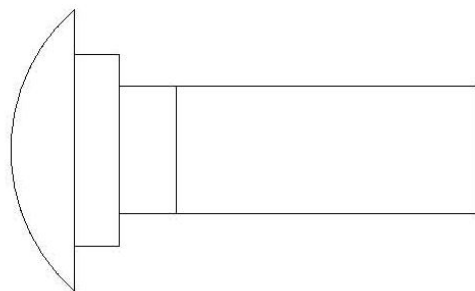
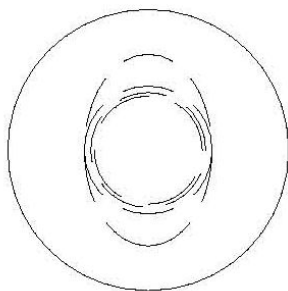

ITEM 42 003400G BOLT RAIL, 5/8X2, G (18)

Step 8 (CONT'D) (QUEST® 70/TL-2, Skip this step)

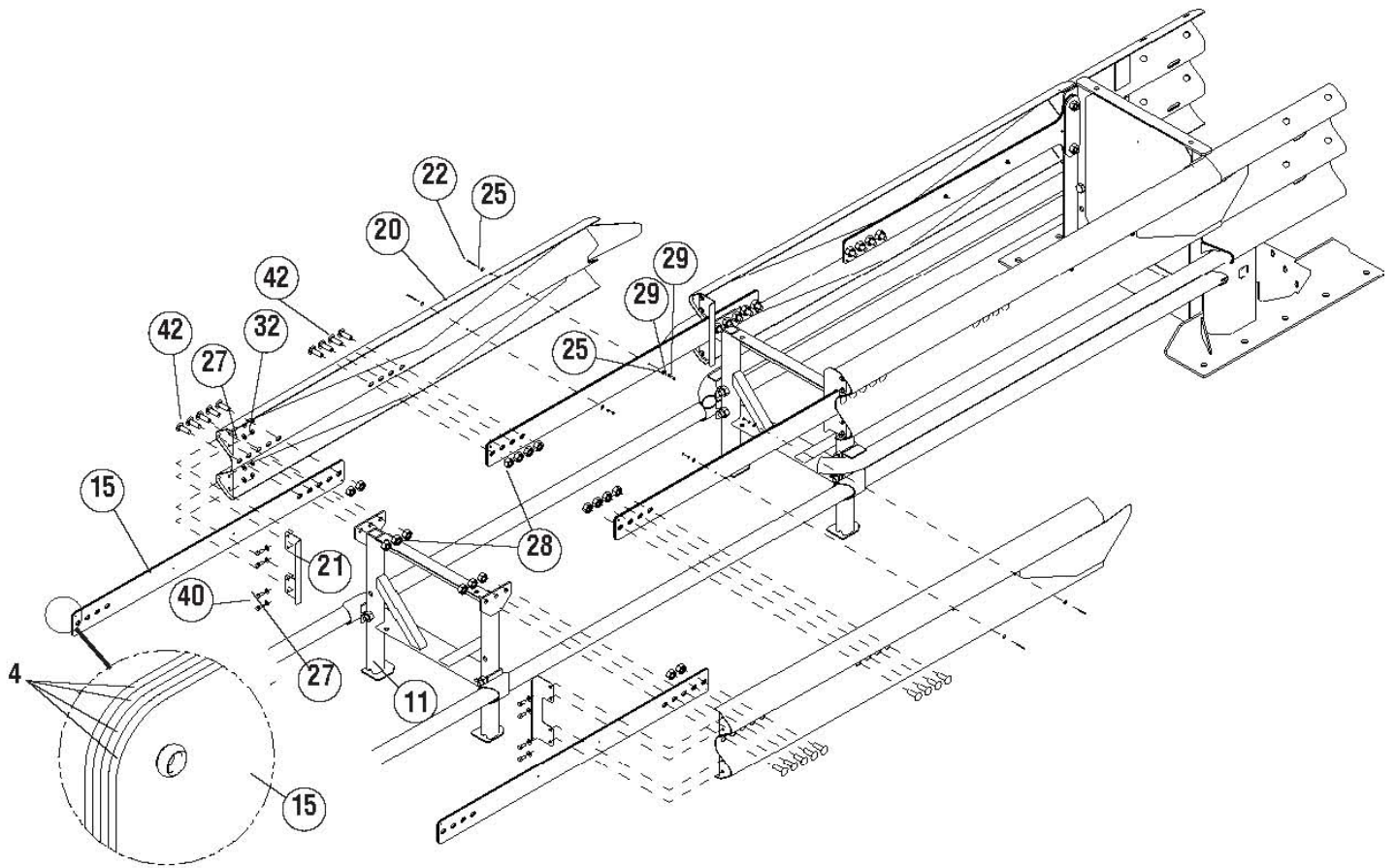

QUEST® 100/TL-3 & QUEST® 115/TL-3 MOD

Step 9 (QUEST® 70/TL-2 & QUEST® 100/TL-3, Skip this step)



ITEM 22 116933B SCREW, PN,#6-32X1 1/2,PHIL,S (4)

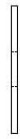
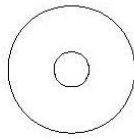

ITEM 25 117987B WASHER, FLAT,#6X5/8X.030, S (8)

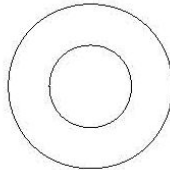

ITEM 27 118030G WASHER.FLAT, 3/8 ID X 13/16 OD, P, HRD (16)

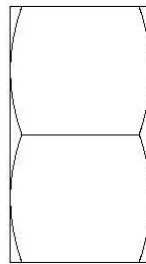
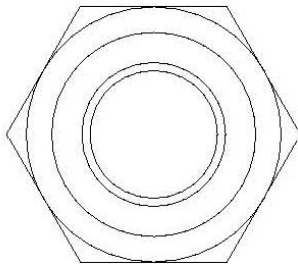

ITEM 28 003340G NUT, HX, 5/8, G, RAIL (18)



ITEM 29 115914B NUT, HX, #6-32, S (8)

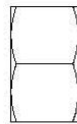
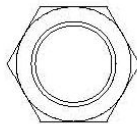

ITEM 32 115960G NUT, HX, 3/8, G (8)

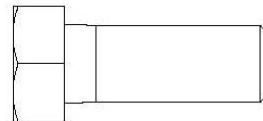
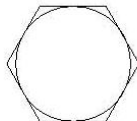

ITEM 40 113596G BOLT, HX, 3/8X1, G2, G (8)

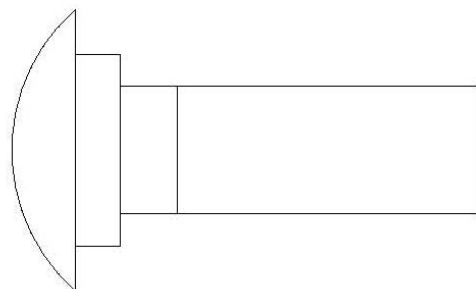
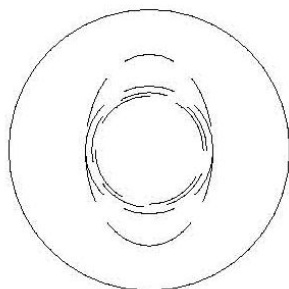

ITEM 42 003400G BOLT RAIL, 5/8X2, G (18)

Step 9 (Cont'd) (QUEST® 70/TL-2 & QUEST® 100/TL-3, Skip this step)

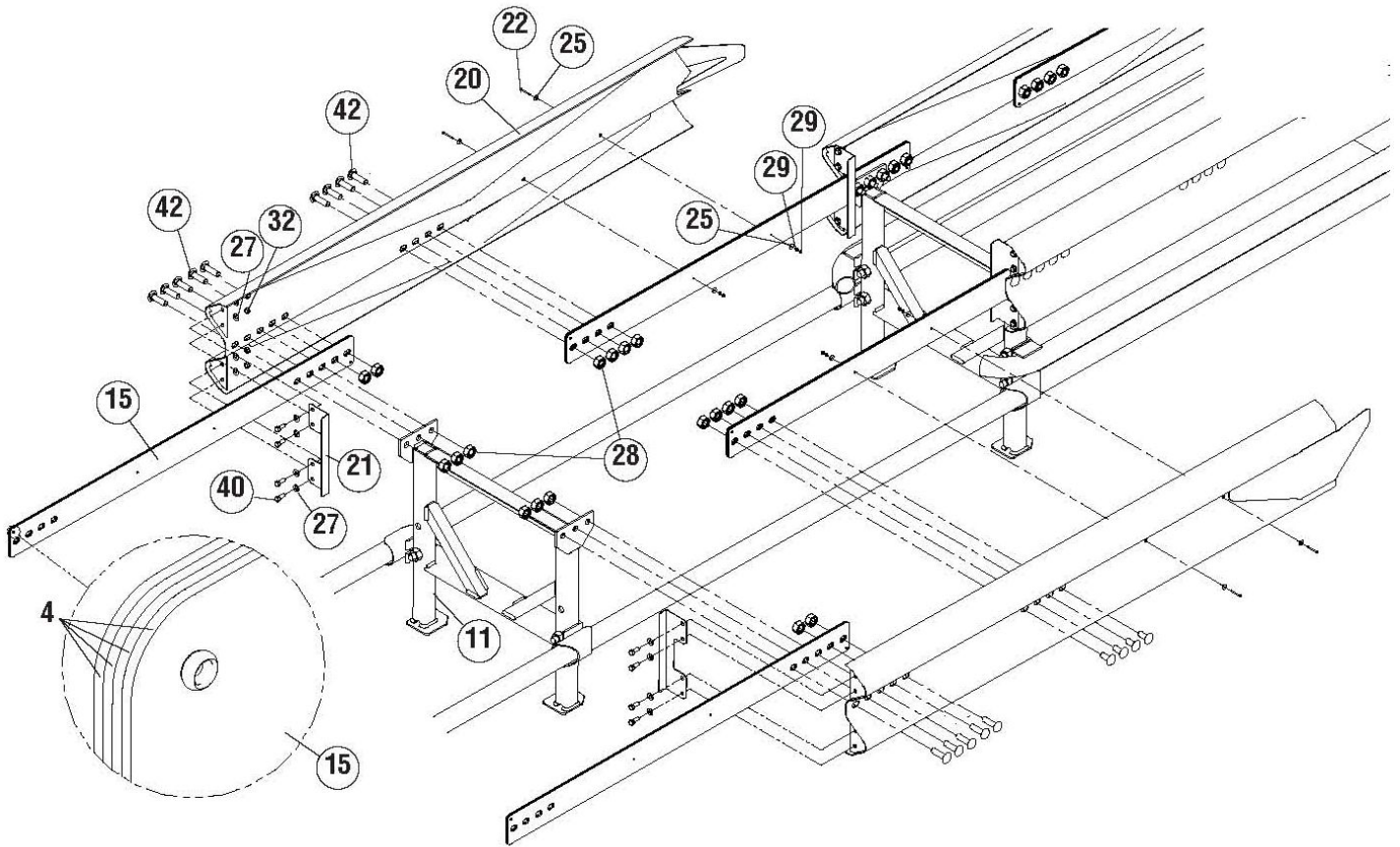

QUEST® 115/TL-3 MOD

Step 10 (x2)

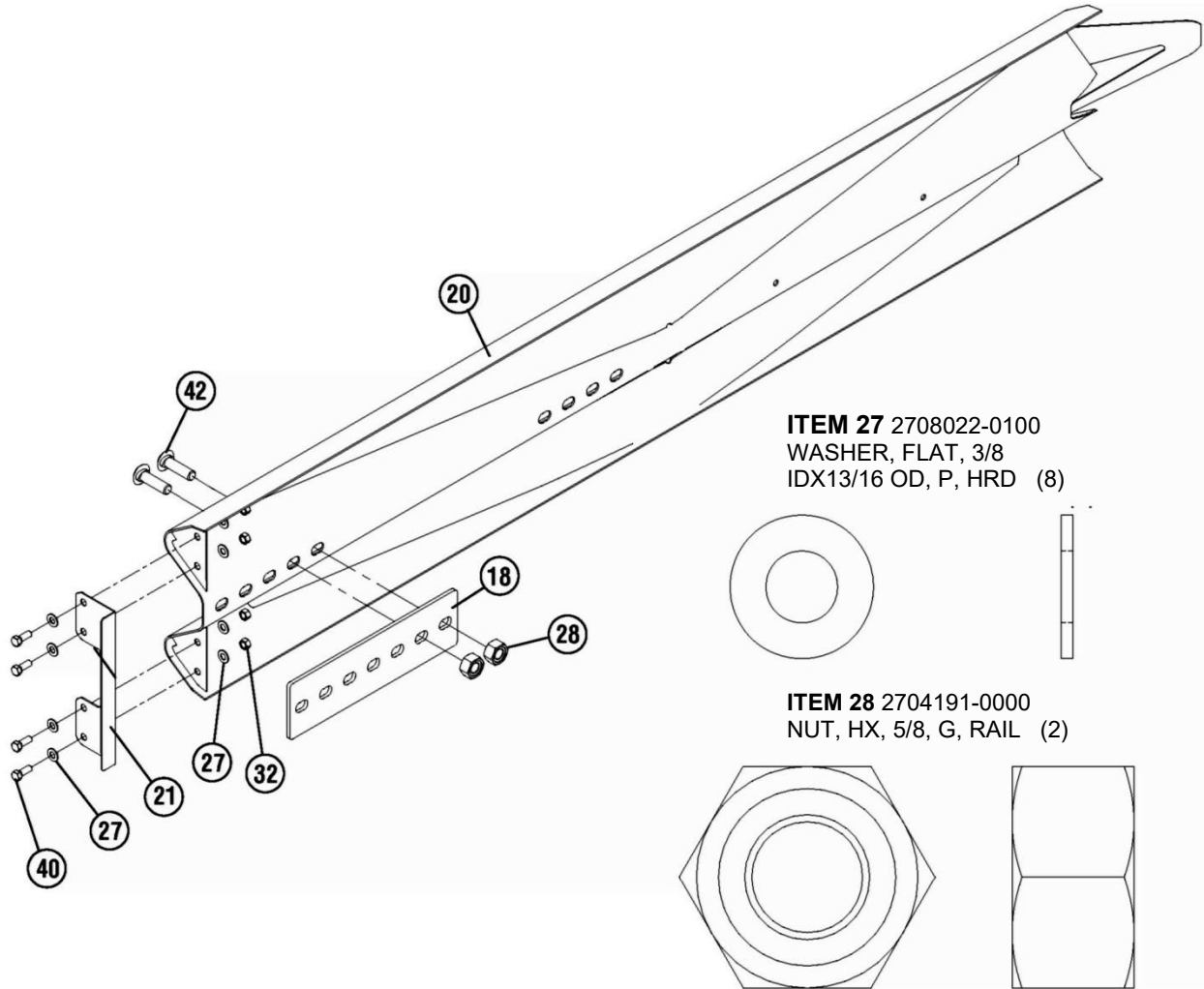

ITEM 27 2708022-0100
WASHER, FLAT, 3/8
IDX13/16 OD, P, HRD (8)

ITEM 28 2704191-0000
NUT, HX, 5/8, G, RAIL (2)

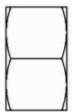
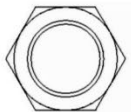

ITEM 32 2704031-0000
NUT, HX, 3/8, G (4)

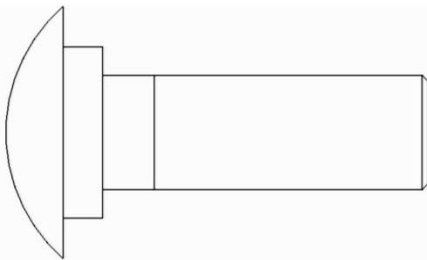
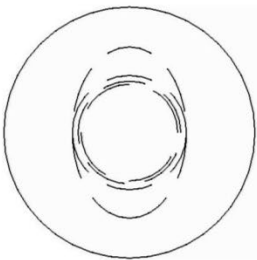

ITEM 42 2699341-0000
BOLT, RAIL, 5/8X2, G5, G (2)

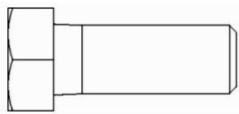
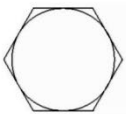

ITEM 40 2701221-0000
BOLT, HX, 3/8X1, G2, G (4)

Step 11

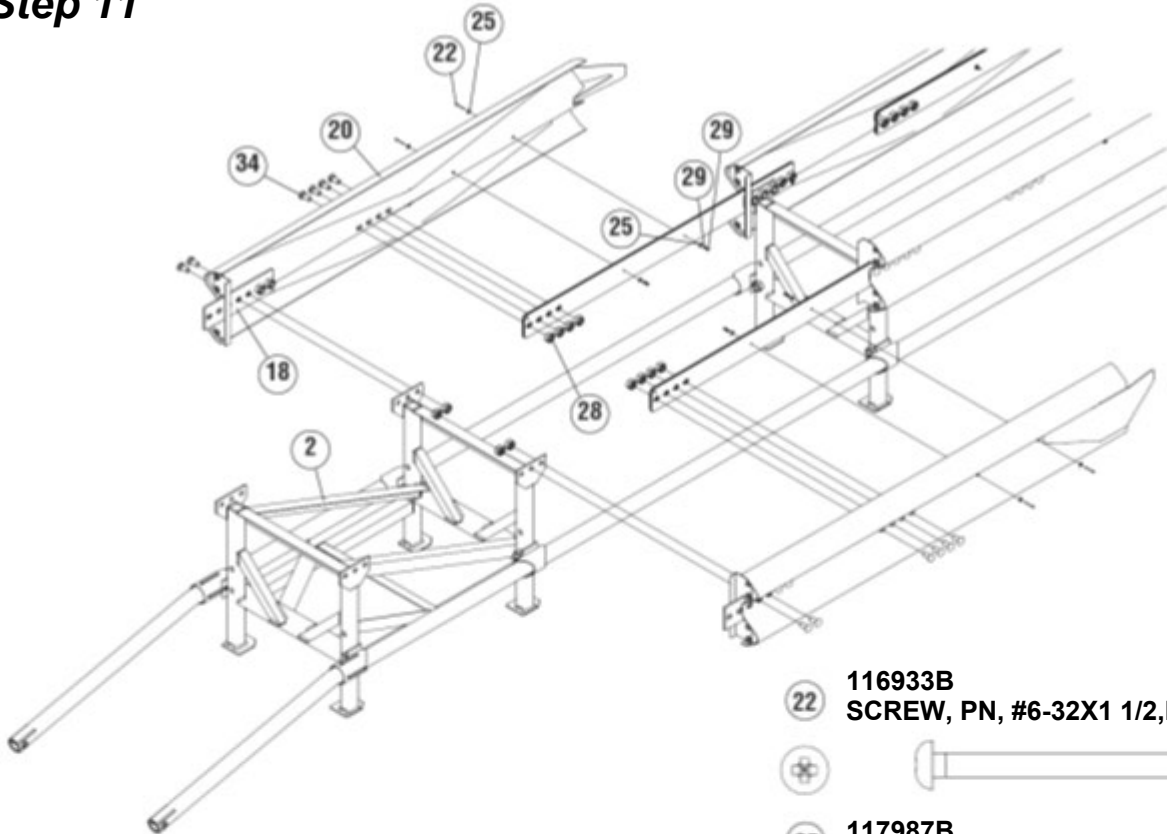

22 116933B
SCREW, PN, #6-32X1 1/2,PHIL,S (4)



25 117987B
WASHER, FLAT, #6X5/8X.030,S (8)



28 003340G
NUT, HX, 5/8, G, RAIL (12)



29 115914B
NUT, HX, #6-32, S (8)



34 003400G
BOLT, RAIL, 5/8X2, G (8)

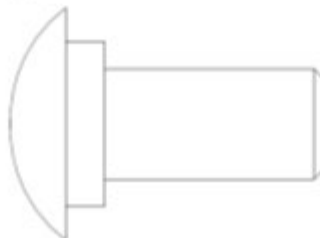

Step 12

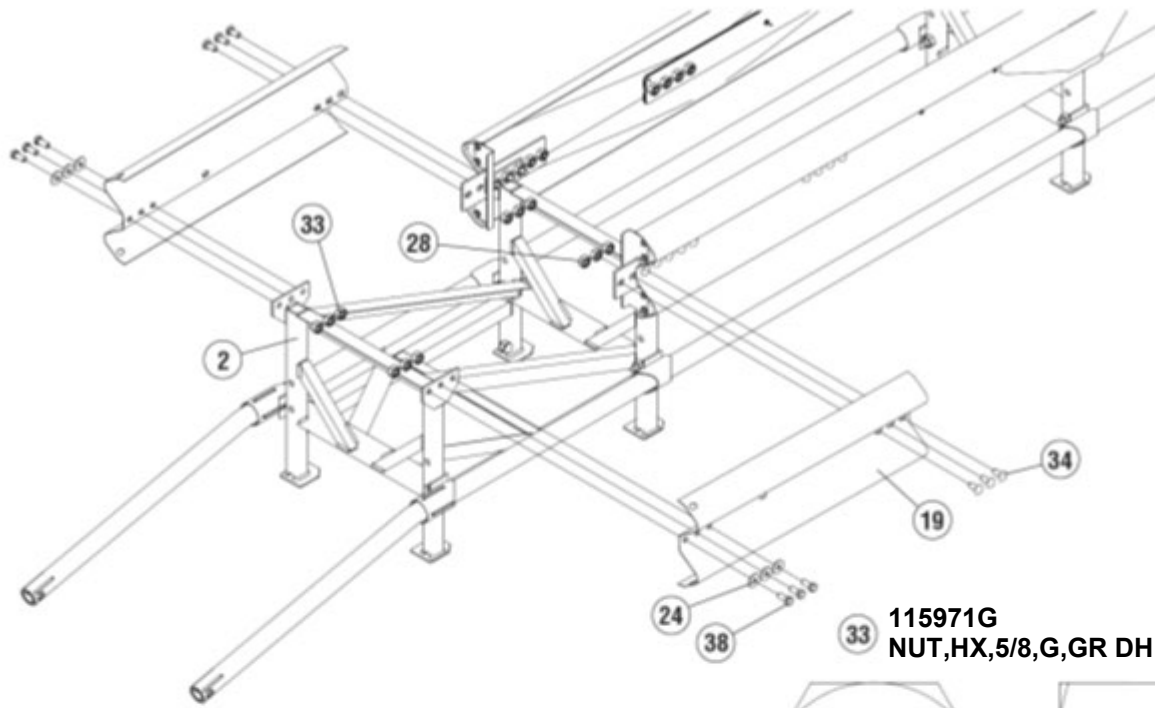

115971G
NUT, HX, 5/8, G, GR DH (6)

24 003300G
WASHER, FLAT, 5/8X1 3/4, G (6)



34 003400G
BOLT, RAIL, 5/8X2, G (6)

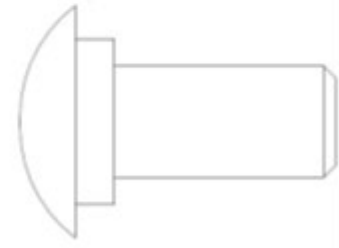

28 003340G
NUT, HX, 5/8, G, RAIL (6)



38 113654G
BOLT, HX, 5/8X1 1/2, G5, G (6)

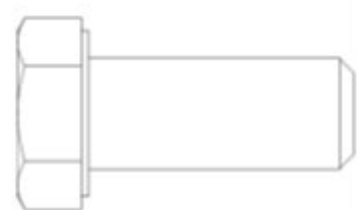

Step 13

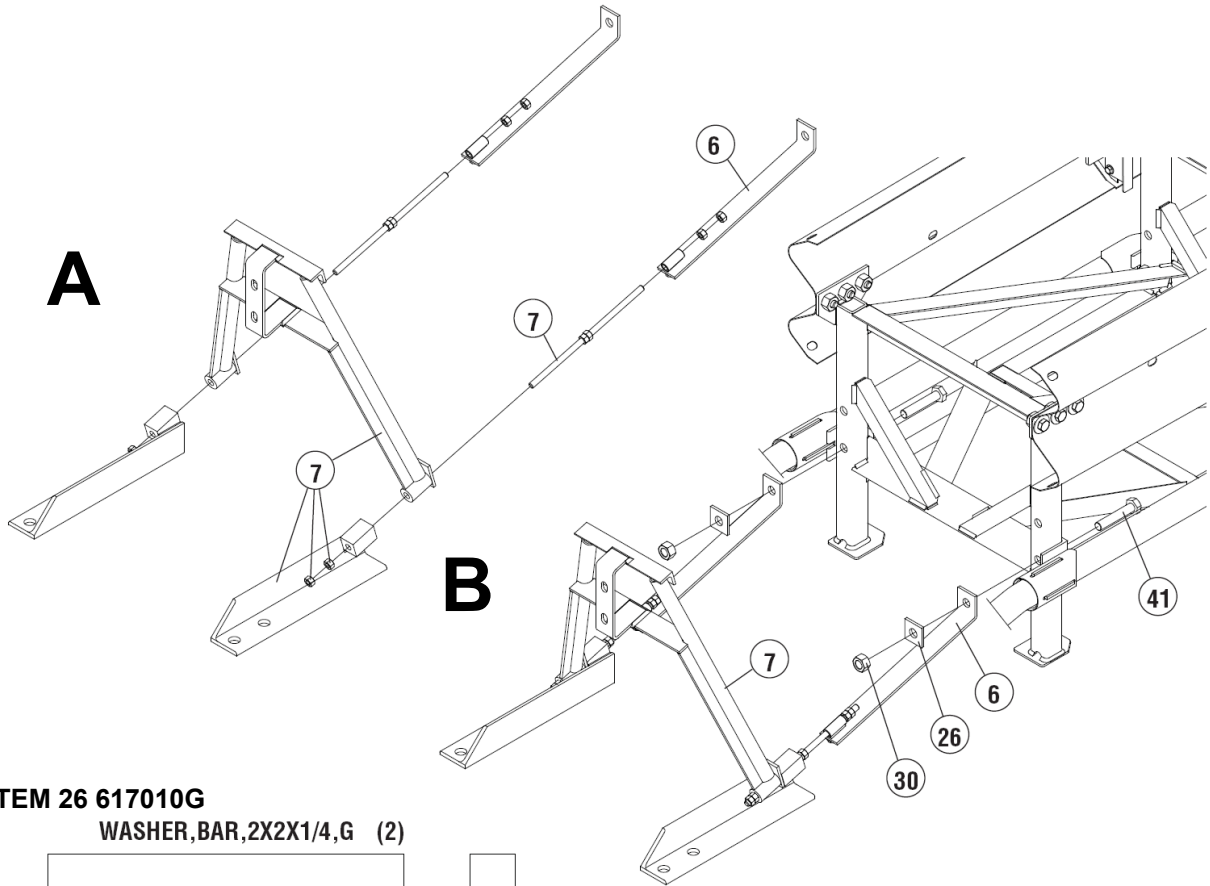

ITEM 26 617010G
WASHER, BAR, 2X2X1/4, G (2)

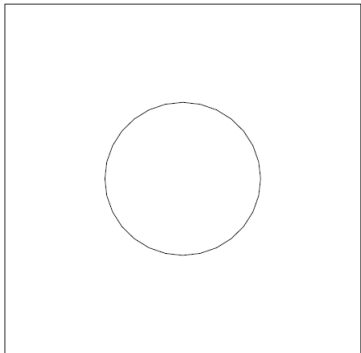

ITEM 30 003704G
NUT, HX, 3/4", GR DH (2)

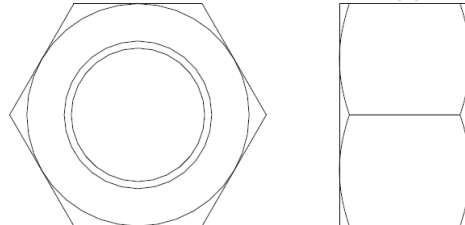

ITEM 41 113568G
BOLT, HX, 3/4X4, G5, G, ALL THRD (2)

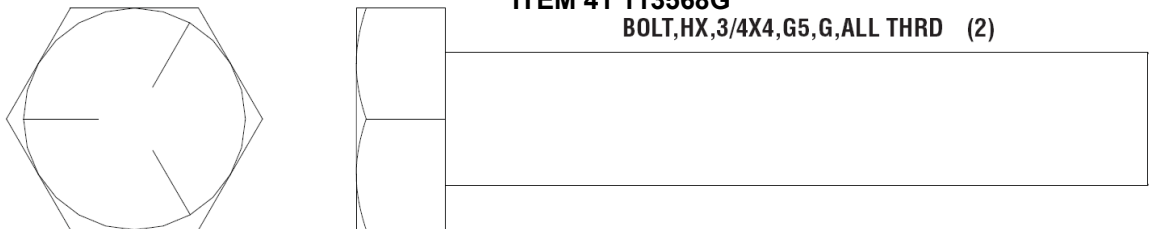

Step 14

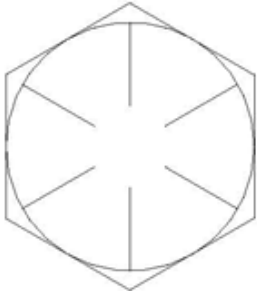
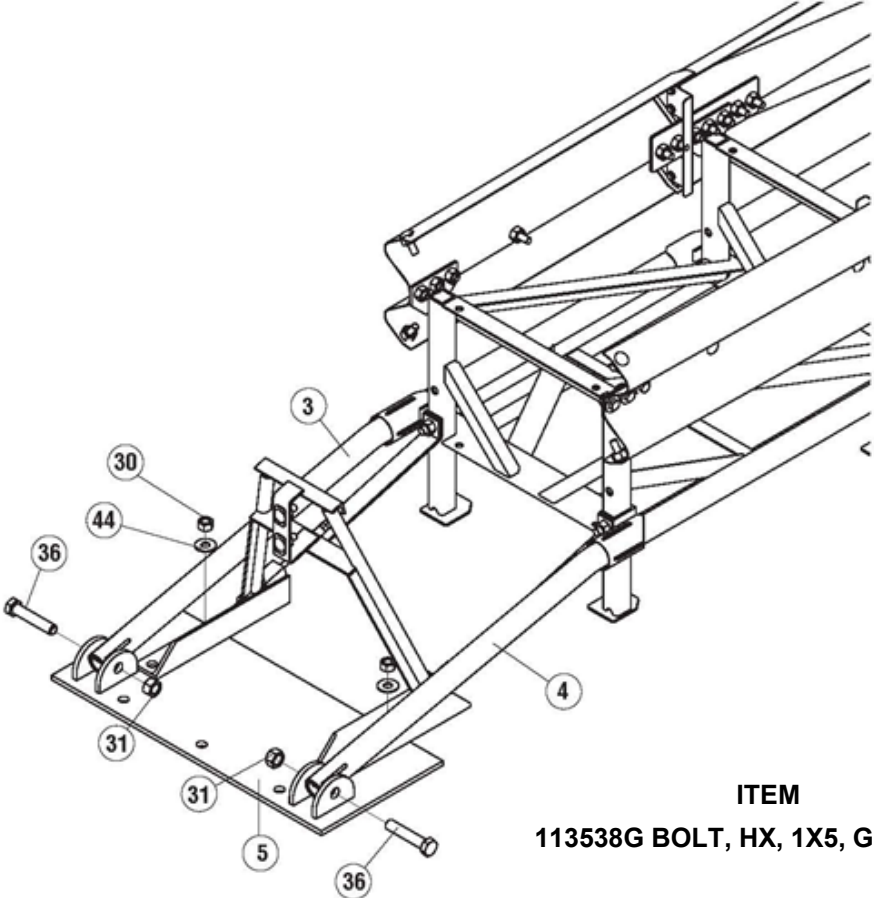

**ITEM
113538G BOLT, HX, 1X5, G8, G (2)**



ITEM 30 003704G NUT, HX, 3/4, GR DH

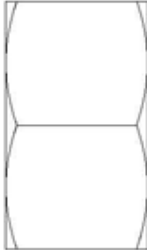

ITEM 31 115931G NUT, HX, 1, G (2)

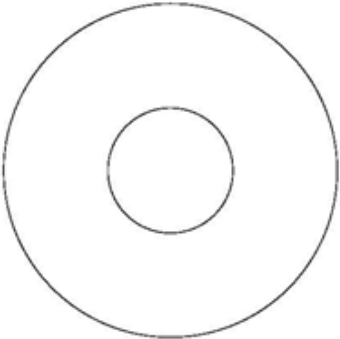

ITEM 44 118027G WASHER, FLAT, 3/4X2, HVY (2)

Step 15a

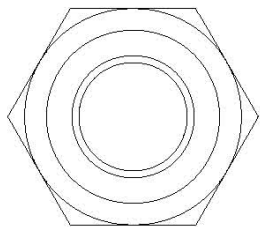
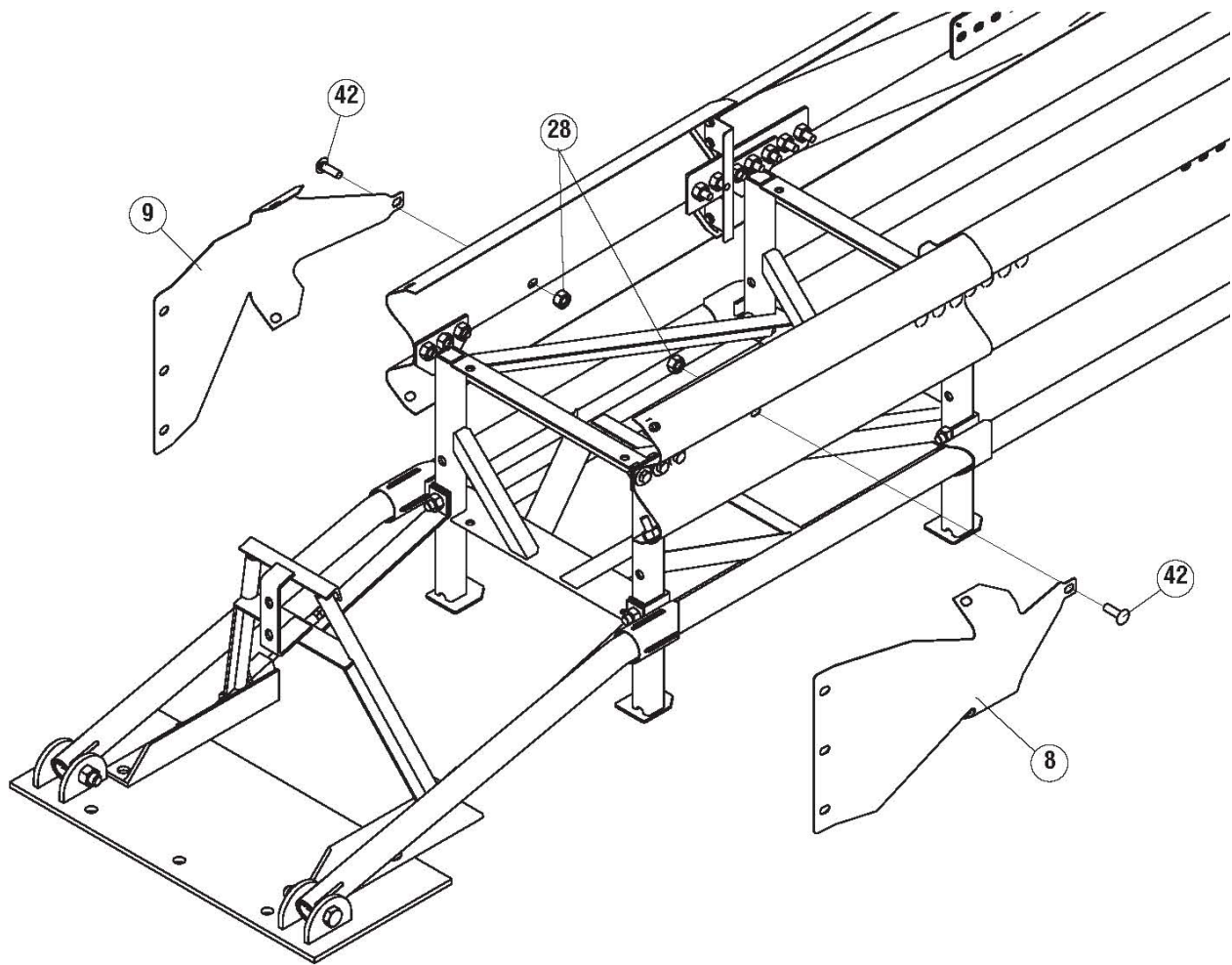

ITEM 28 003340G NUT, HX, 5/8, G, RAIL (2)

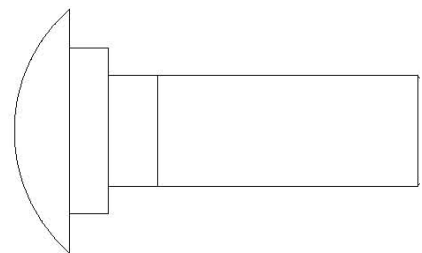
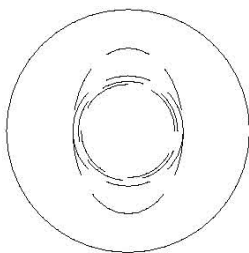
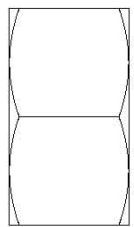

ITEM 42 003400G BOLT, RAIL, 5/8X2, G (2)

Step 15b

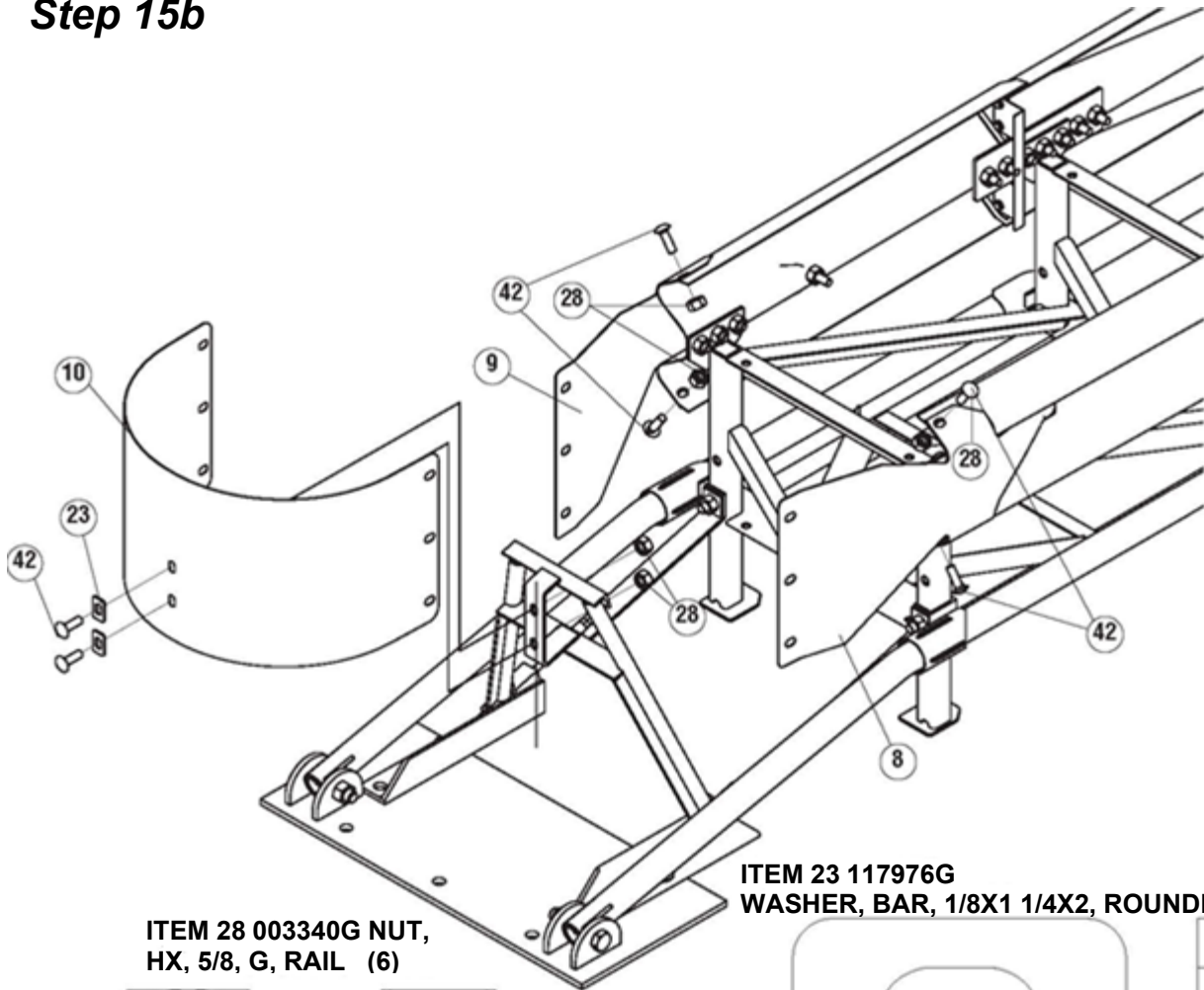

ITEM 28 003340G NUT, HX, 5/8, G, RAIL (6)

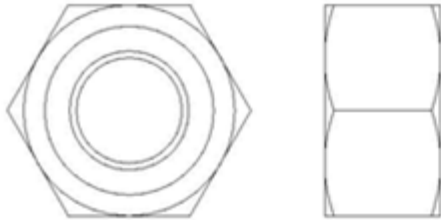

ITEM 23 117976G WASHER, BAR, 1/8X1 1/4X2, ROUNDED, G (6)

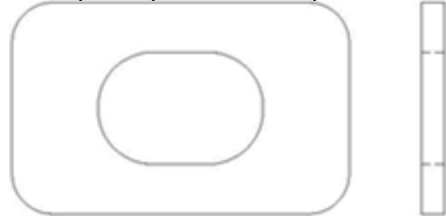

ITEM 42 003400G BOLT, RAIL, 5/8X2, G (6)

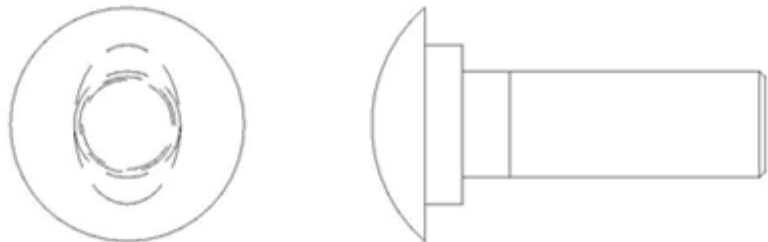

Step 15c

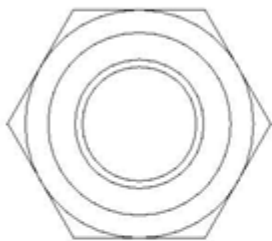
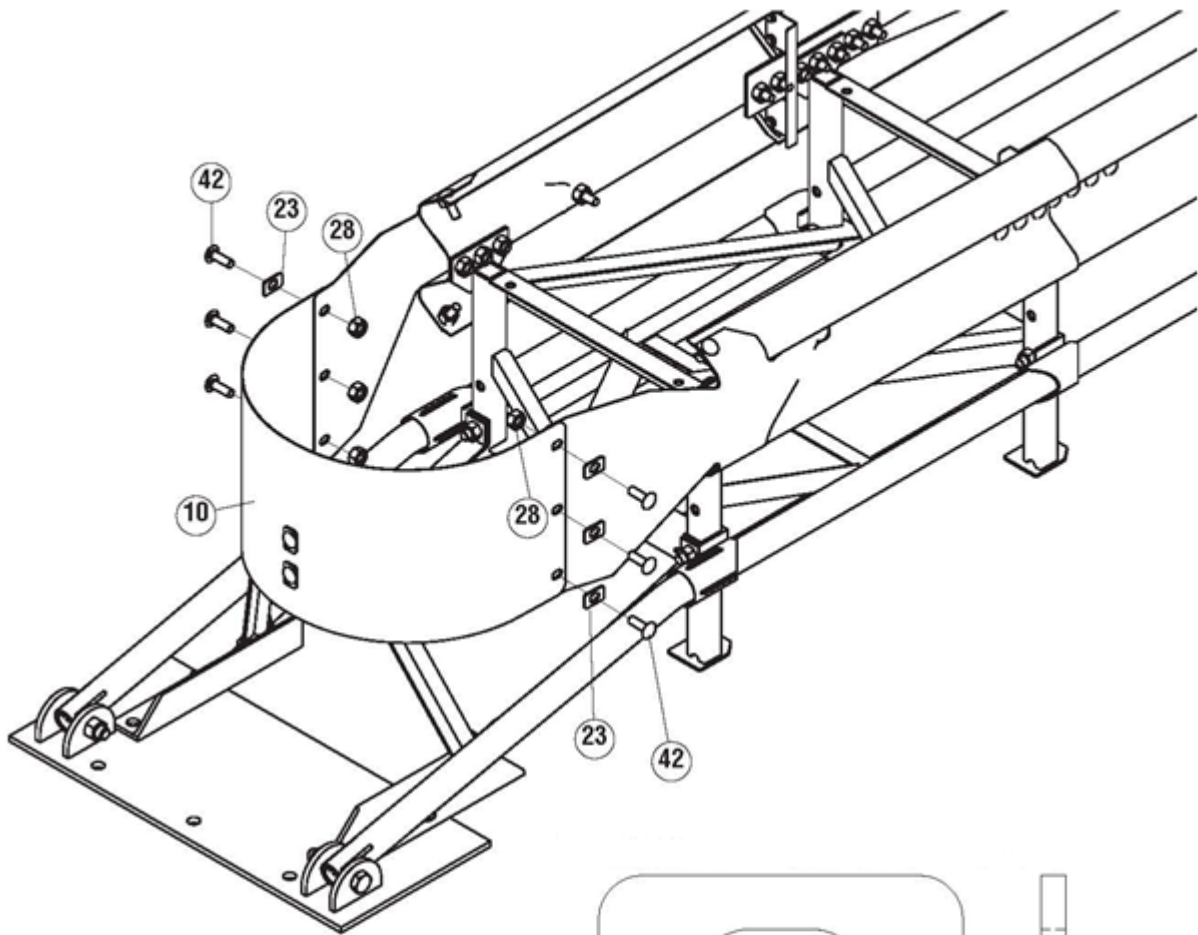

ITEM 28 003340G NUT, HX, 5/8, G, RAIL (6)

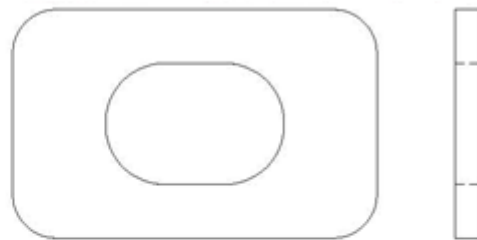

ITEM 23 117976G
WASHER, BAR, 1/8X 1 1/4X2, ROUNDED, G (6)

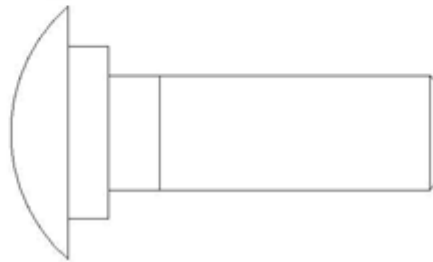
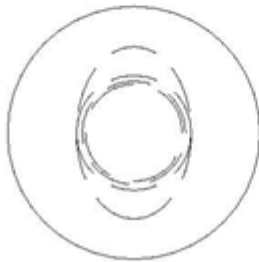

ITEM 42 003400G BOLT. RAIL. 5/8X2. G (6)

Recommended Tools

Documentation

- Manufacturer's Assembly Manual
- Manufacturer's Drawing Package

Personal protective equipment

- Eye protection
- Gloves
- Safety-toe shoes
- Protective clothing

Cutting equipment

- Rebar Cutting Bit - 22 mm [7/8"]
- Concrete Drill Bits - 22 mm [7/8"] (*Double Fluted)
- Grinder, Hacksaw or Torch (optional)
- Rotary Hammer Drill



Important: Valtir recommends using **double-fluted** drill bits to achieve optimum tensile strength when applying an approved adhesive anchoring system.

Wrenches

- Heavy Duty Impact Wrench - 1/2" Drive
- Standard Adjustable Wrench - 12" [300 mm]
- 1/2" drive sockets: 1 1/8", 1 1/4", 1 1/2"
- 3/8" drive sockets: 1/4", 1/2"
- Deep Sockets: 1 1/4"
- Ratchet and attachments for the above sockets
- Breaker Bar: 1/2" x 24"
- Torque Wrench: 200 ft-lbf
- 2 ea. Open/Box End Wrench - 1/4", 1/2", 3/4"

Hammers

- Sledgehammer
- Standard Hammer

Miscellaneous

- Traffic Control Equipment
- Lifting and Moving Equipment (A lifting device is preferred although a forklift can be used.) Minimum 5,000 lb. capacity required.
- Compressor (100 psi)
- Generator (5 kW)
- Long Pry Bar
- Drift Pin 12" [300 mm]
- Center Punch
- Tape Measure 25' [7.5 m]
- Chalk Line
- Concrete Marking Pencil
- Steel bristled brush for cleaning 7/8" drilled holes
- Rags, Water, and Solvent for Touch-up

Note: The above list of tools is a general recommendation and should not be considered an extensive list. Depending on specific site conditions and the complexity of the assembly specified by the appropriate highway authority, the required tools may vary. Decisions as to what tools are needed to perform the job are entirely the responsibility of the specifying highway authority and the authority's selected contractor performing the assembly of the system at the authority's specified assembly site.

Cross-Slope

Assembly cross-slope should not exceed 8% and should not vary more than 2% over the length of the system; the pad surface should have a light broom finish (Figure 4).

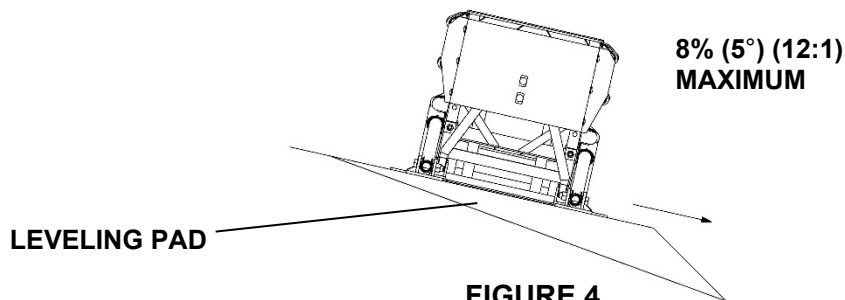

**FIGURE 4
CROSS-SLOPE**



Warning: Location of the backup in relation to the hazard and nearby objects will affect the operation of the attenuator. Upon impact, the shaper rails stroke toward and extend beyond the rigid backup and hazard as much as 6' [1.82 m] from their pre-impact location, therefore the backup must nest around concrete walls, barriers and pillars. Failure to comply with this requirement may result in impaired system performance offering motorists less protection.

Assembly Procedures

Note: The drawing package provided with the QUEST® must be used with these instructions for proper assembly and should take precedence over these general instructions.

1) Deploy Traffic Control

A traffic control plan appropriate to the complexity of the project should be prepared and understood by all parties before the QUEST® is assembled. Follow the traffic plan set forth by the applicable highway authority.



Important: Deploy the appropriate work zone safety devices, as directed by the highway authority, prior to beginning the assembly and keep them present through all phases of the assembly.

2) Determining the Base point and Centerline

Typically the base point of the QUEST® will be the midpoint of the hazard at its front face.

Extend a chalk line from the base point, perpendicular to the hazard face, or as determined by project engineer; to a distance greater than the maximum length of the QUEST® (refer to the drawings provided). This chalk line will become the centerline for the QUEST® (Figure 5). When properly assembled the QUEST® appears to be an extension of the object which it is shielding (Figure 6).



Warning: The 24" [610 mm], 30" [760 mm] or 36" [915 mm] Backup should nest around concrete walls, barriers and pillars 24" [610 mm], 30" [760 mm] or 36" [915 mm] in width or less, respectively. Failure to nest the Backup around these types of hazards may result in untested system performance.

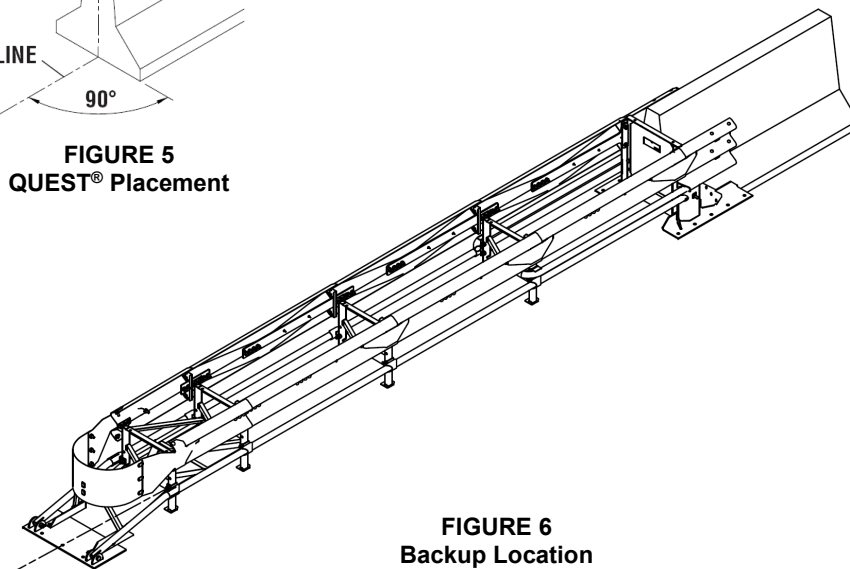
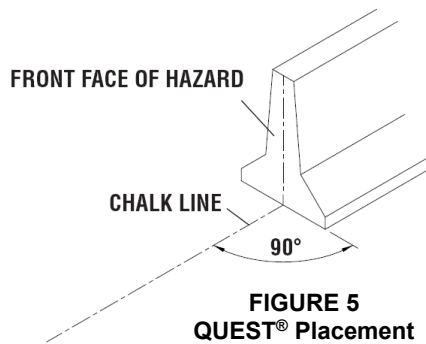

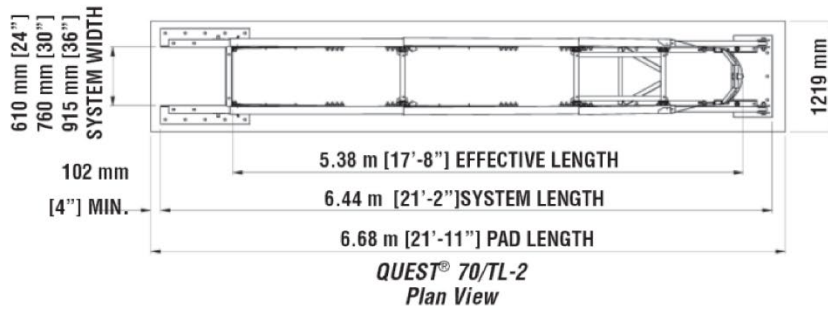

[48"] PAD WITH (24" SYSTEM)
54" [1372 mm] PAD WITH (30" SYSTEM)
60" [1524 mm] PAD WITH (36" SYSTEM)

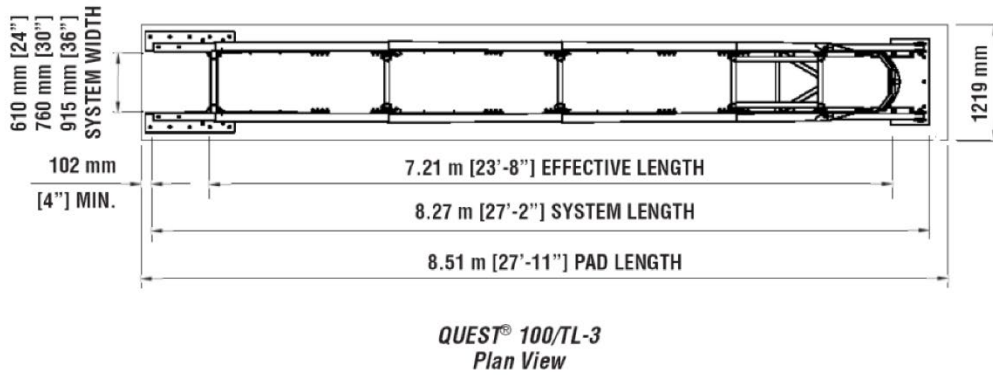

[48"] PAD WITH (24" SYSTEM)
54" [1372 mm] PAD WITH (30" SYSTEM)
60" [1524 mm] PAD WITH (36" SYSTEM)

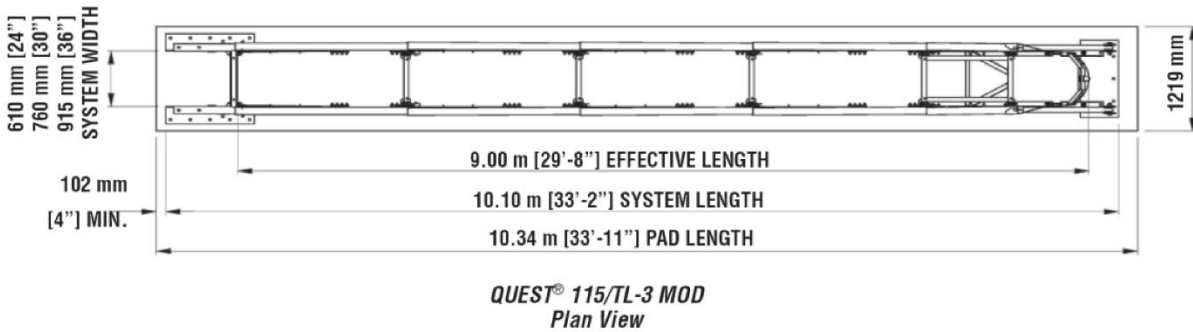

[48"] PAD WITH (24" SYSTEM)
54" [1372 mm] PAD WITH (30" SYSTEM)
60" [1524 mm] PAD WITH (36" SYSTEM)

FIGURE 7
Backup Location

3) Setting the Shaper Rails

Ensure the Spacers (Item 43) are placed around the bolts (Item 37) inside the window in the Backup. Snug the bolts so the Shaper Rails don't move when the system is lifted. Once the system is placed, the bolts can be loosened 1/2" and the front of the system pulled out if more slack is desired (Figure 8).

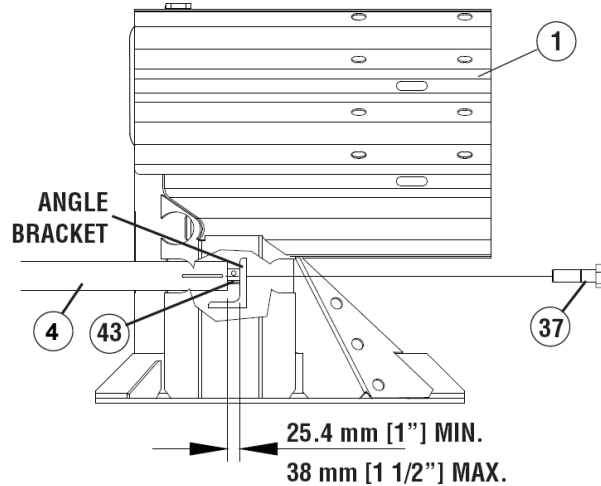

FIGURE 8
Tension Shaper Rail Bolts



Warning: The tensioning bolt must have slack thread available to tighten the Shaper Rail after anchoring the system.

4) Lifting and Placing the System

Use the lifting points to lift the QUEST® into place (Figures 9a, 9b and 9c).



Warning: Do not lift the system using the Tube Rails or Fender Panels. Lift the system using the Diaphragms, Backup and Support Frame only. Lifting the system by the Tube Rails or Fender Panels will cause damage to the system.

Use fixed-length slings with a 3,000 lbs. [1,360 kg] minimum capacity. Fixed slings will prevent the system from tipping.



Danger: Do not lift the system over any personnel. Do not stand below or behind the system when performing this function. Failure to heed this warning could result in injury or death.

For assemblies shielding concrete wall, safety shape barrier or pillar, the steel Backup should be nested around the hazard (Figure 6).

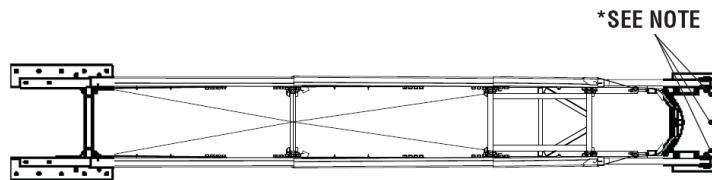

Note: Maximum stud height for front anchor locations shown is 1.5" [40 mm] (Figure 12).

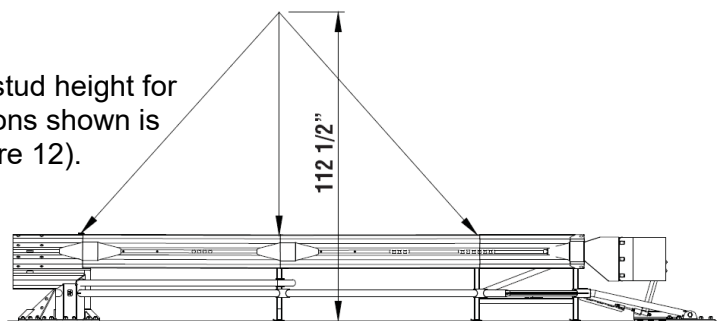

FIGURE 9a

5) Drill and Set Anchors

Use the holes in the Backup and Front Anchor Plate as a template to locate and drill holes. The Backup requires ten (10) approved adhesive anchors, five (5) anchors on the left side and five (5) anchors on the right side. The Front Anchor Plate requires five (5) anchors.

For Concrete Assemblies

Drill 7/8" [22 mm] diameter x 5 1/2" [140 mm] deep holes into the concrete pad or roadway (Figure 12). Use approved adhesive kits to assemble 3/4" diameter x 7" long studs using instructions included with kit. After adhesive has hardened, use 3/4" flat washers and nuts provided with kit to anchor system to foundation.

For Asphalt Assemblies

Drill 7/8" [22 mm] diameter x 16 1/2" [420 mm] deep holes into the asphalt roadway. Use approved adhesive kits to assemble 3/4" diameter x 18" long studs using instructions included with kit. After adhesive has hardened, use 3/4" flat washers and nuts provided with kit to anchor system to foundation.

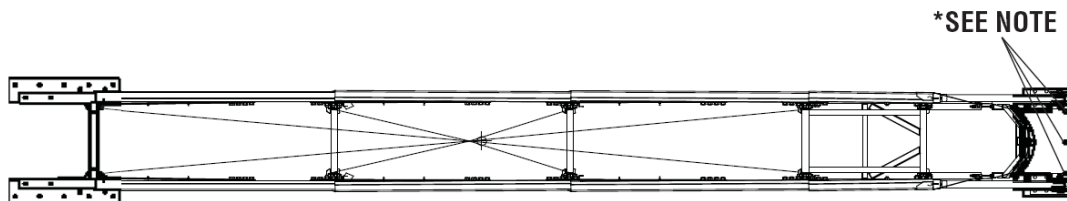

Note: Maximum stud height for front anchor locations shown is 1.5" [40 mm] (Figure 12).

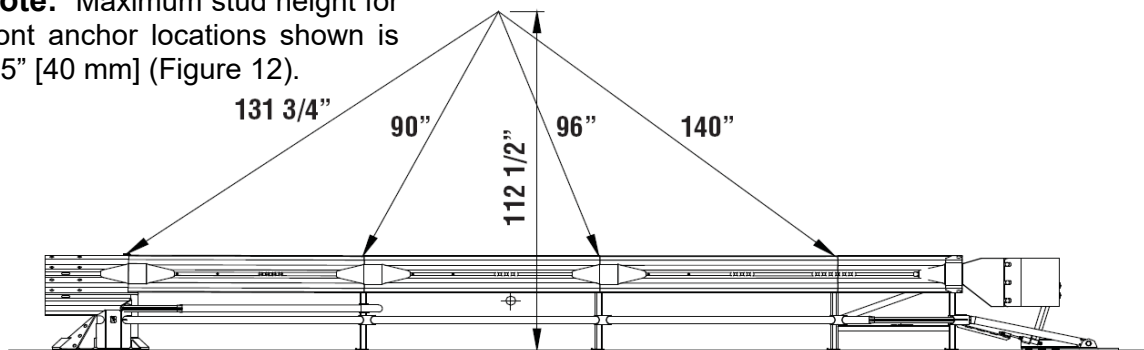
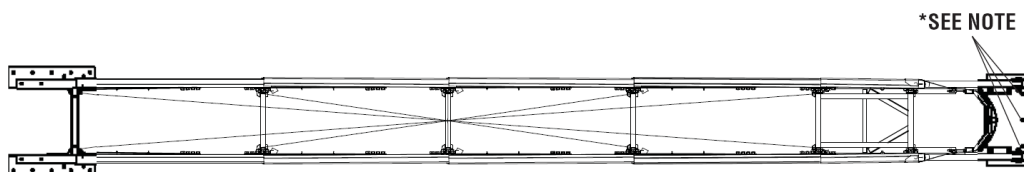

FIGURE 9b



Note: Maximum stud height for front anchor locations shown is 1.5" [40 mm] (Figure 12).

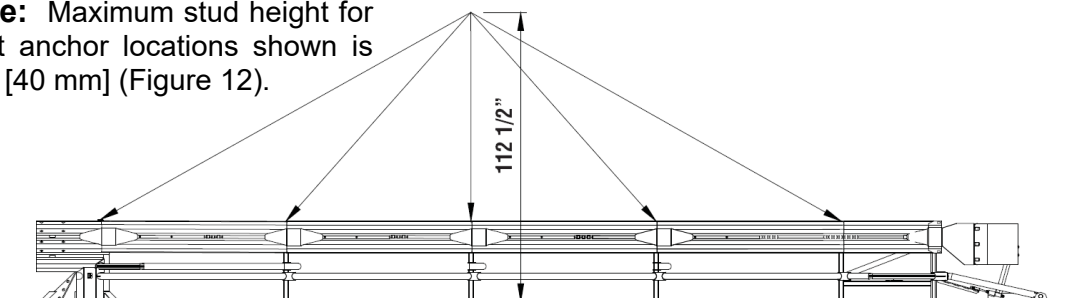

FIGURE 9c

6) Adjusting the Trigger Assembly (See Warnings Below)

Ensure 1" x 5" bolts attaching front of Shaper Tube are tight. Tension threaded rod by tightening upper nut and 1/8 to 1/4 turn past snug. Assemble second nut on upper side and jam (typical both sides). See also procedure outlined in the drawing package (Figure 10).

7) Tension Shaper Rails (See Warnings Below)

Remove the Spacers (Item 43) and tighten 1" x 3 1/2" bolts in the rear of the Shaper Rail Assembly (Figure 6).



Warning: Refer to manufacturer instructions for hardening times:

- 3/4" x 7" Anchor Studs page 9 & Figure 12
- 3/4" x 18" Threaded Rods page 9 & Figure 12
- Trigger Assembly Tighten (Figure 10)
- Tension Shaper Rail Bolts Tighten (Figure 8)



Important: For ease of assembly, nose assembly should be left off until system is anchored. See Steps 15a, 15b, & 15c on pages 43, 44, & 45 for attaching nose assembly.

Bidirectional Traffic

If a QUEST® is placed in a location where traffic will be approaching from the rear, a transition from the object being shielded to the Backup may be required. Hardware is available to mount guardrail or a safety shaped barrier to the Steel Backup of the QUEST®.

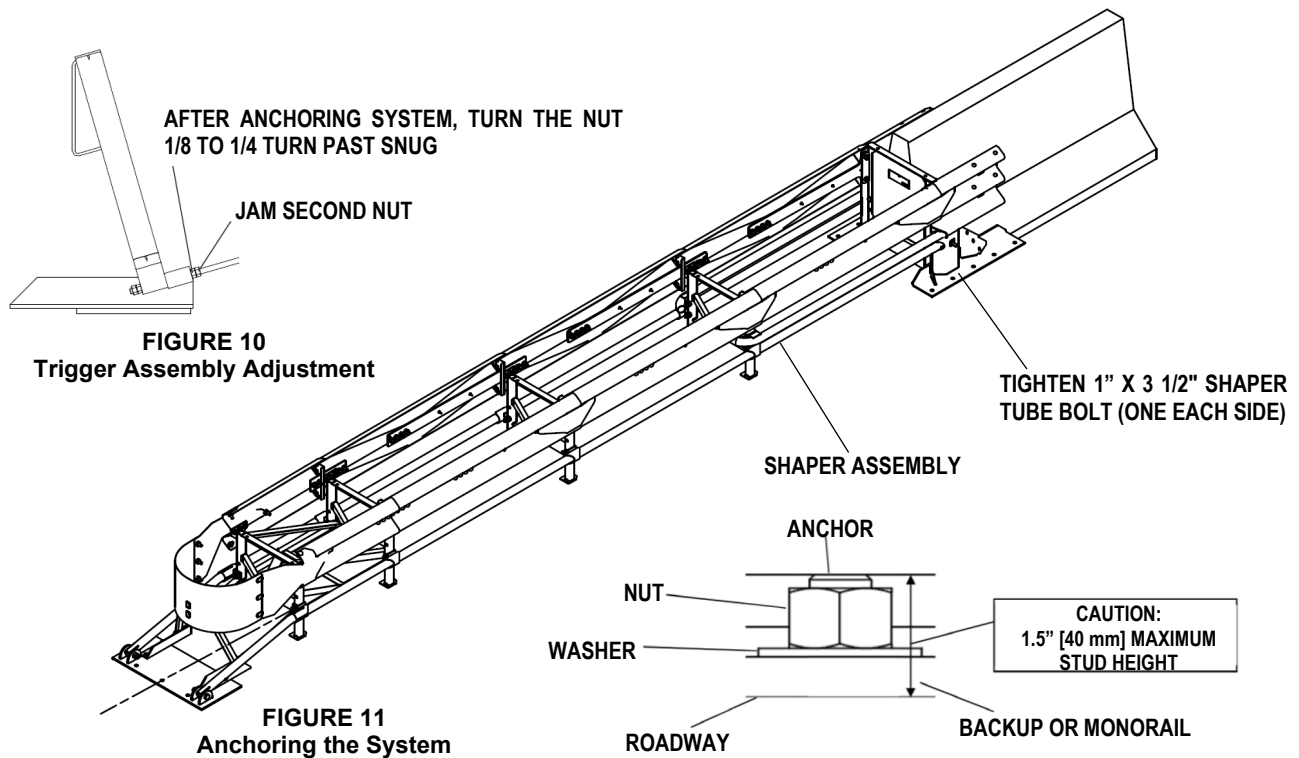

Note: Maximum stud height for front anchor locations shown in Figure 9 is 1.5" [40 mm].

FIGURE 12
Proper Stud Height

Transition and Side Panel Types



Caution: The proper Transition or Side Panel must be used for optimum impact performance of the system. The correct panel to use will depend on the direction of traffic and what type of barrier or road feature the QUEST® is shielding. See assembly drawings if you have any questions.



Warning: Location of the system with respect to the hazard is critical and dependent on the type of Transition Panel used. See project plans supplied with the system for details.

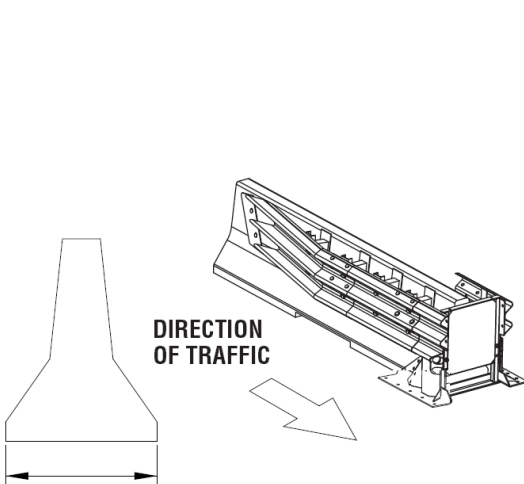

FIGURE 13
Thrie-Beam to Safety Barrier Transition Panel

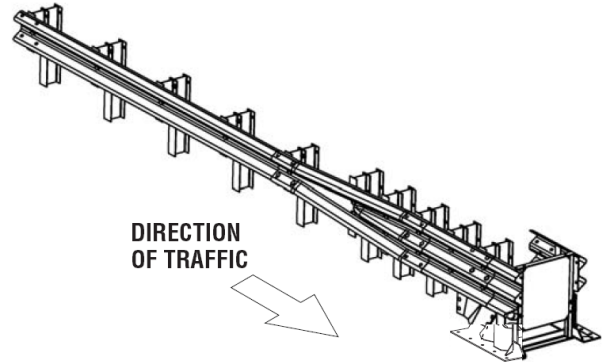

FIGURE 14
Thrie-Beam to W-Beam Transition Panel

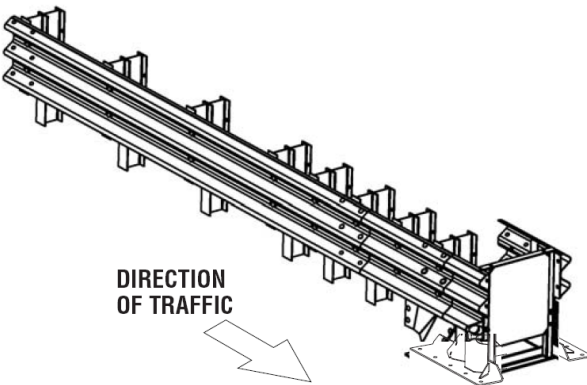

FIGURE 15
Transition to Thrie-Beam Guardrail

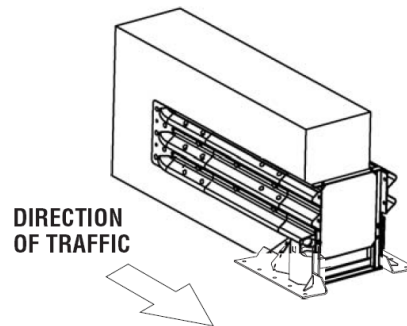

FIGURE 16
Thrie-Beam End Shoe Transition Panel

QUEST® Road Feature Width	
Maximum Width	Model No.
24" [610 mm]	TDXXX24
30" [760 mm]	TDXXX30
36" [915 mm]	TDXXX36

XXX = 70 kph [TL-2], 100 kph [TL-3], or 115 kph (SPEED)
115/TL-3 MOD only available for 24" [610 mm]

Maintenance Checklist

Frequency of maintenance required will depend upon site conditions. Visual drive-by inspections, by the appropriate highway authority, are recommended at least once a month. Walk-up inspections are recommended at least once a year for assemblies on concrete and at least once every six months for assemblies on asphalt.

Visual Drive-By Inspection

- 1) Check to see if there is any evidence of an impact (deformed Nose or Side Panels). If so, a walk-up inspection will be necessary.
- 2) Check to see that the surface under the system is clear of debris to ensure performance as tested.
- 3) Note the location, condition of the QUEST® System, and the date of the visual drive-by inspection. Drive-by inspections are recommended on an as needed basis based upon traffic volume, site accident history, etc.

Walk-Up Inspection

- 1) Clear and dispose of any debris on the site.
- 2) Be sure all bolts are tight and rust-free.
- 3) Be sure anchor bolts are securely anchored.
- 4) Be sure the Shaper Rails are tensioned and rust-free.
- 5) Check to see that the Trigger Bolts in the Front Anchor Assembly are intact.
- 6) Check to see that the Support Frame Assembly has not engaged the Shaper Rails. Both Shapers must be over the forward-most part of the pre-crimped portion of the Shaper Rails.
- 7) Check to see that the laminated straps at the Fender Panels are intact and connection points are assembled correctly.
- 8) Check to make sure that the Diaphragm legs are on grade level and clear of debris.
- 9) Note the location and condition of the QUEST® System for entry in the impact attenuator inspection logbook under the date of this inspection. Walk-up inspections are recommended on an as needed basis based upon traffic volume, site accident history, etc.
- 10) Refer to Post-Impact Instructions for more information.

Post Impact Instructions

After an impact occurs, the system should be repaired or replaced as soon as possible. Due to its light weight, short length and minimal number of anchors, the QUEST® has been shown to be relatively simple for field repair or rapid replacement of the entire unit.

Depending upon the severity of the impact and site conditions, the QUEST® can be either refurbished on the roadside or repaired in the maintenance shop away from traffic dangers.

Some QUEST® components may remain undamaged after less severe impacts, making refurbishment possible. Entire systems can be repaired and then reused on the roadside or damaged portions can be refurbished and reused as needed.



Warning: Whether a system is repairable or reusable is a decision that can only be determined by the highway authority who has specified the use of this device. That decision is never made by the designer or manufacturer of the system.

Repair Procedure

- 1) Deploy the appropriate traffic-control devices to protect your crew.
- 2) Clear and dispose of any debris on the site.
- 3) Check all components of the QUEST®. Any components that are bent or damaged must be replaced. After some impacts on the nose, it is possible that the only parts that will be reusable are the backup and front anchor assemblies.
- 4) To refurbish the QUEST®, disassemble the system and replace the damaged parts with new parts.
- 5) The shaper rail assemblies must be replaced if the support frame has begun to crimp the pipes.
- 6) During the process of refurbishment, follow the assembly drawings and instructions.
- 7) Check to be certain that the site is free from any debris.
- 8) The QUEST® is now ready for service.

Parts Ordering Procedure

- 1) Make a list of all damaged parts using the part descriptions and part numbers shown on the assembly drawings.
- 2) Contact the Valtir Customer Service Department (p. 3).

Notes:

Notes:

Notes:



For more complete information on Valtir products and services, visit us on the web at www.valtir.com. Materials and specifications are subject to change without notice. Please contact Valtir to confirm that you are referring to the most current instructions.

WWW.VALTIR.COM
1.888.323.6374